



SPELTHORNE DESIGN CODE

SPELTHORNE BOROUGH COUNCIL

Contents

1	Introduction	4	4	Area Type Design Requirements	39
	What does the Design Code include?	5		Spelthorne's Area Types	40
	How to use the Design Code	6	4.1	High Streets	42
	About Spelthorne	8	4.2	Town Centre Neighbourhoods	48
2	The Design Process	14	4.3	Inner Suburban	86
	Approach	15	4.4	Suburban	94
	Key Steps	17	5	Areas of Change	115
3	Places Past, Present and Future	21	5.1	Staines-upon-Thames Town Centre	116
	Staines-upon-Thames	22	5.2	Sunbury Cross	152
	Ashford	25	6	Preparing your Application	163
	Sunbury-on-Thames	28		What you need to do now	164
	Shepperton	31		How to get further help	165
	Stanwell	34	6.1	Checklists	166
	The Villages	37		Glossary	179

Prepared for Spelthorne Borough Council by



Fathom Architects



The Spelthorne Design Code Project Team would like to acknowledge everyone in the community in Spelthorne who has given up time to contribute to the development of this Code, whether through walking tours, school and youth groups, online feedback, public events or as part of the Citizens Panel. Your assistance, expertise and enthusiasm has been invaluable and is much appreciated.



Introduction

- » The Spelthorne Design Code
- » What does the Design Code include?
- » How to use the Design Code
- » About Spelthorne

The Spelthorne Design Code

WHAT IS THE SPELTHORNE DESIGN CODE?

The Spelthorne Design Code has been produced to provide a framework to support high quality design in the borough, that is reflective of local character and design preferences. It sets out the design requirements for proposed new development to ensure that it is locally supported, sustainable and functions well for all.

It has been drafted to accord with national planning policies and guidance, including the National Model Design Code.

It is underpinned by an overarching Vision and Principles and more detailed Visions for each place within the Borough. The Design Code covers a range of Area Types that share similar design characteristics and issues. It places a particular focus on Areas of Change, identified by the [Local Plan](#), which are subject to more detailed Design Requirements.

The Design Code is based on wide-ranging inputs including that from the Spelthorne community, other stakeholders and a wider understanding of the places within the borough, to ensure it is locally-supported, robust and can be used in practice. The process has prioritised and been based around local engagement at every stage, including the use of an innovative Citizens Panel (a demographically representative group of Spelthorne residents), to ensure that the Code reflects and responds to community views and visions for the Borough.

HOW IT WILL BE USED TO DETERMINE PLANNING APPLICATIONS

The Design Code will be used to determine whether planning applications are acceptable in design terms and will support the emerging Spelthorne [Local Plan](#). It contains simple, concise, illustrated design requirements for streets, open spaces and buildings. It also sets out expectations for the process to be followed when proposals are designed.

Applicants for planning permission will need to demonstrate adherence to the Design Requirements in their proposals and planning applications. Whether a development meets the Design Code requirements will then be a material consideration in the determination of the planning application.

The Design Code has been produced in parallel with, and to support, the Spelthorne [Local Plan](#). Together, the [Local Plan](#) and Design Code, will support the delivery of high quality development and infrastructure in the most appropriate location. It has been adopted as a Supplementary Planning Document (SPD) to provide guidance on how proposals should achieve policy compliance.

The Code is not intended to stifle design creativity and the highest quality design, but to ensure that all development in Spelthorne demonstrates and delivers good design.

USERS

The Spelthorne Design Code is intended to be used by the following groups of users:

- Developers applying for planning permission and their design teams
- Planning officers and planning committee members assessing the suitability of proposed designs
- The wider community, seeking to understand what sort of development is supported in their local area

HOW WAS IT CREATED?

The Design Code was created through extensive community and stakeholder engagement, and in-depth urban design analysis of the existing borough and anticipated future development.

A full account of the process is set out in Appendix B.

What does the Design Code include?

The Spelthorne Design Code sets out the design requirements for proposed new development in the borough. It will ensure that new development is locally supported, sustainable and functions well for all its users.

The Design Code will be used to determine whether planning applications are acceptable in design terms, and will support the emerging Spelthorne Local Plan. It contains simple, concise, illustrated design requirements for streets, open spaces and buildings. It also sets out expectations for the process to be followed when proposals are designed. It is based on wide-ranging input including that from the local community, other stakeholders and wider understanding of the places within the borough, to ensure it is locally-supported, robust and can be used in practice.

The Spelthorne Design Code includes:

- A vision for development in the borough and its key places
- Design principles across a range of topics
- Expectations for a comprehensive and considered approach to the design process
- Tailored design requirements for different area types within the borough, covering Buildings, Open Spaces, Streets and Public Realm, Landscape and other physical aspects of the design of proposals.

Other local policy documents deal with different areas of the built and natural environment in Spelthorne.

The [Local Plan](#) covers:

- The amount and location of development
- The delivery of supporting infrastructure
- Policies that deal with flooding, developer obligations, affordable housing and others

Surrey County Council's **Local Transport Plan 4** covers:

- Transport policies, schemes and other transport matters

Surrey County Council also publishes the **Healthy Streets Design Code**, which sets out the requirements for the design of streets and highways. Its key requirements have been included in this Code.

The Spelthorne **Local Cycling and Walking Infrastructure Plan** identifies networks and priorities for investment to support walking, cycling and other forms of active travel in the borough.

New designs and proposals should have regard to the Surrey County Council **Local Nature Recovery Strategy (LNRS)**, ensuring green infrastructure and biodiversity enhancements align with identified local priorities for habitat restoration and species recovery.

The Spelthorne Local Plan is supported by a number of Supplementary Planning Documents (SPDs), that provide further guidance on how to implement Local Plan policies.

INFORMATION IN APPENDICES

The Design Code is supported by a series of Appendices:

Appendix A: Understanding Spelthorne Today

This appendix sets out relevant background design information about the borough today, including:

- Historic Development
- Green and Blue Infrastructure
- Movement
- Built Form
- People & Places
- Future Development
- Detailed characterisation of Spelthorne's Area Types

Appendix B: Community Engagement

This appendix sets out how the Code was created in collaboration with the community in Spelthorne.

Appendix C: Residential Extensions Guidance

This appendix adds further information to the key dimensional guidance for residential extensions. It is drawn from the previous 'Design of Residential Extensions and New Residential Development' Supplementary Planning Document (SPD).

FINDING THE INFORMATION YOU NEED



This icon in the Code highlights areas and themes identified as particularly important to the community.



This icon in the Code highlights where you can **find out more** about a subject in supporting appendices.

This highlighted and underlined text indicates that this is a key term that is defined in the glossary.

The top of each page shows the section you are in. The section numbering and the Code requirements are numbered consistently.

Example: Area Types (Chapter 4)

Chapter Area Type Theme



Example: Areas of Change (Chapter 5)

Chapter Area of Change Area Type



AREA TYPES AND AREAS OF CHANGE

The Design Code sets out Design Requirements for developments in different Area Types in Chapter 4. They are denoted by **purple text**, for ease of cross-reference.

In some parts of the borough, such as Staines-upon-Thames town centre, it is anticipated that there will be significant new development and change. These Areas of Change have additional detail and Design Requirements set out in Chapter 5.

DESIGN REQUIREMENTS

Design Requirements are set out as follows:

Aim: an explanation as to why this set of requirements is important, and what outcome should be achieved. This Aim is particularly important for non-standard design proposals that propose innovative and high-quality approaches to achieve the same outcome (see 'Comply or Justify').

Requirements are then arranged as follows:

- **Must:** all proposals must comply
- **Should:** all proposals should comply unless non-compliance can be justified, and demonstrating compliance will add supporting weight to the design element of the planning application decision

ADVISORY DESIGN GUIDANCE

Some parts of the Code set out guidance, best practice or design inspiration from elsewhere that could provide the basis for the development of design proposals. These are design ideas that development **could** implement, and are highlighted as such.

COMPLY OR JUSTIFY

The Design Code is to be used following a principle of **'Comply or Justify'**. Deviation from requirements set out will only be permitted with robust and evidence-based justification that any proposed design solutions still achieve the underlying Aim of the requirement.

Deviation from **'must'** requirements will require a very high level of justification.

Proposals that do not comply with these principles and fail to provide compelling justification are likely to be refused

About Spelthorne

Spelthorne is a borough in the north of Surrey, on the fringes of London, with a population of around 100,000 people. It sits on the northern banks of the River Thames, and to the south of Heathrow Airport.

Until the late 19th century, the area was a predominantly rural part of the former county of Middlesex, with Staines as the main market town. The arrival of the railway and growth of London sparked several waves of suburban growth, transforming the existing towns and villages into the suburban fringes of London, balancing the attractiveness of living near a city with the green open spaces of the countryside, common to much of 'urban' Surrey and the former areas of Middlesex elsewhere on London's fringes today. Since the creation of the Metropolitan Green Belt in the early 1970s, the built-up area has changed very little. The borough's built character is strongly related to its historic development patterns.

The borough hosts major infrastructure, particularly reservoirs, water supply and motorways that support London and the wider south-east. Kempton Park, Shepperton Studios and BP's offices in Sunbury are significant landmarks and destinations.

Spelthorne is likely to see significant residential-led development in the future, particularly in its well-connected town centres. Well-designed development offers a significant opportunity to create new, integrated and valued places and neighbourhoods that could provide benefit to new and existing communities.

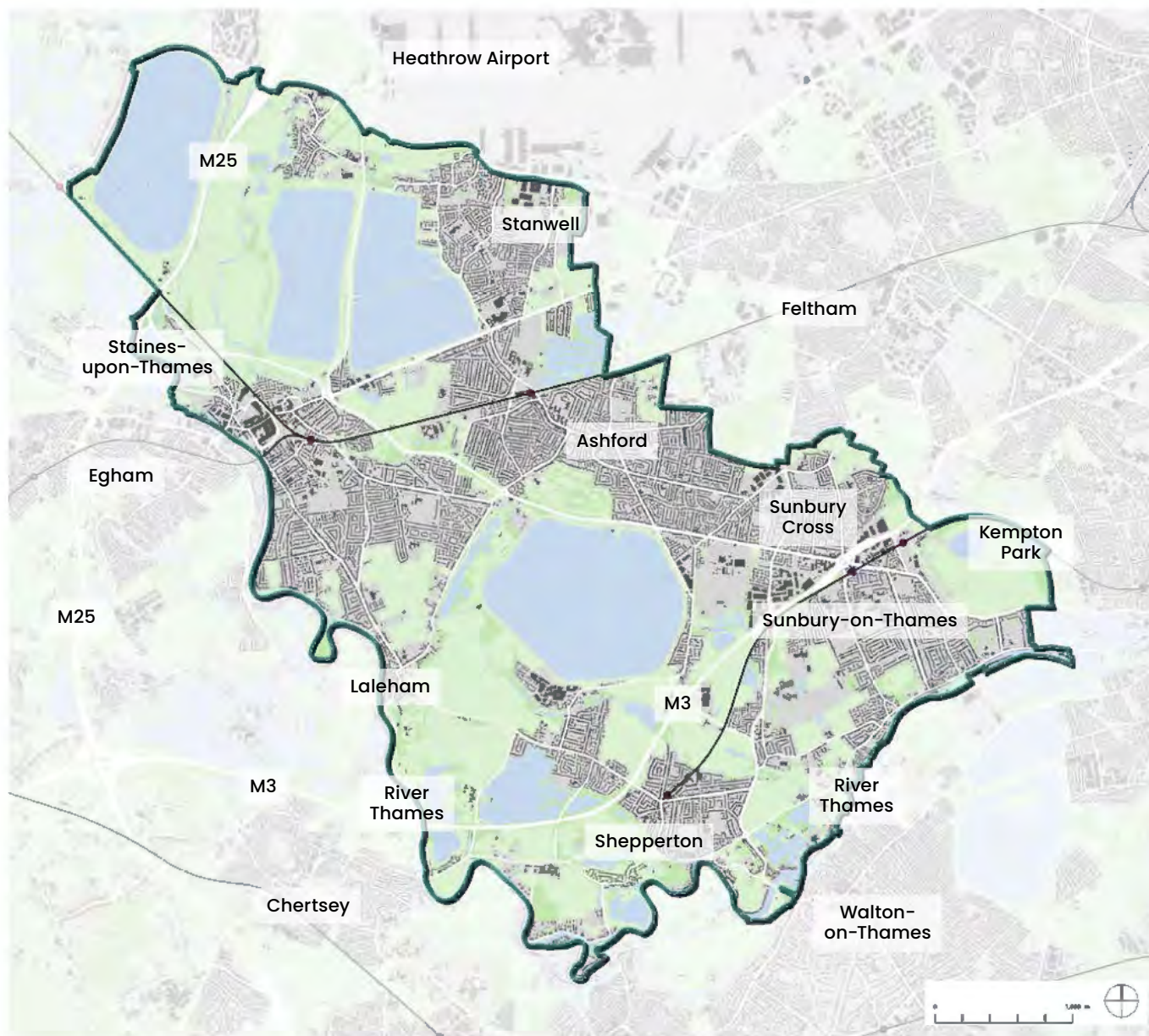

Find out more background information about the borough in Appendix A 'Understanding Spelthorne Today'.

Key features of Spelthorne

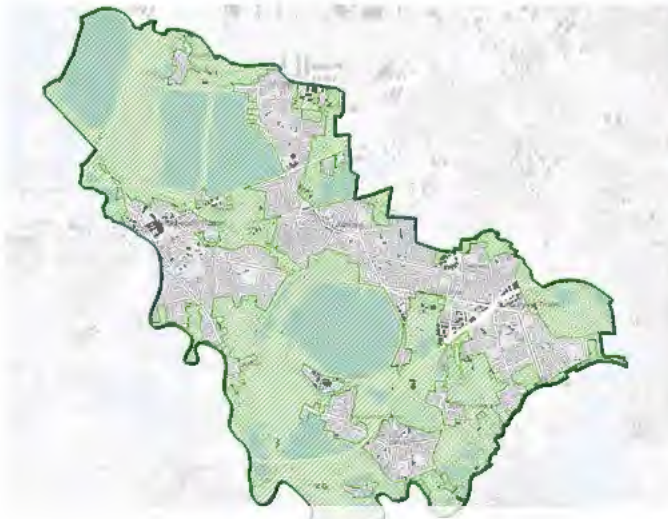

Green Belt

Much of the borough is covered by the Metropolitan Green Belt, placing a strong focus on development in existing built up areas.

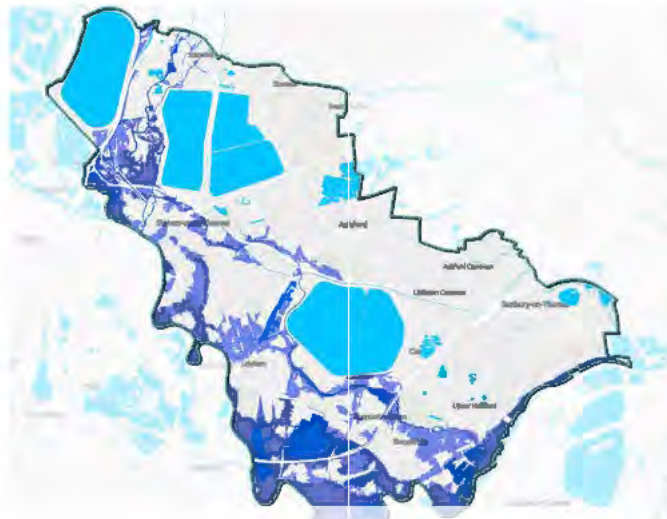

Water

Bounded by the River Thames to the south, Spelthorne hosts major reservoirs and water supply infrastructure for the wider London and southeast, as well needing to manage flood risks.



Urban Morphology

Many parts of Spelthorne bear the hallmark of the era in which they were developed, with strong patterns of regular plots, straight streets and suburban development.



Attractive green open spaces

Green open spaces are much valued by the community and there are a wide variety, from parks to spaces for nature.



The River Thames

The River Thames provides an opportunity for leisure, exercise and breathing space, but in places the frontage is underused and could be improved.



Busy High Streets

Spelthorne's places are focused on bustling and vibrant high streets that provide local distinctiveness and valued retail and community provision.

The Design Vision & Borough-Wide Principles

The Design Code has drawn on the views of the local community to define what good design is in Spelthorne, and the vision for how places should look, function and engage the community (both present and future) in coming years. The vision is set out across five themes, with supporting design principles to help make it happen.

BOROUGH-WIDE DESIGN VISION

All development in Spelthorne will contribute to achieving the vision for future design of places in the borough.

BOROUGH-WIDE DESIGN PRINCIPLES

All proposals for new development in the borough **must** apply the following design principles.

WHERE DID THIS COME FROM?

The Vision for the future and Principles for change were developed by the Spelthorne Design Code Citizens Panel and wider community through the engagement process.



Sustainable Urban Design

Blend modern infrastructure and development with heritage through sustainable, high-quality and timeless architecture and design, reflecting the borough's historic identity on the edges of both city and countryside.



Commitment and Connections to Green Space

Protect, maintain and rejuvenate green spaces, with a focus on the importance of integrating natural areas into urban environments for residents' well-being and improved biodiversity.

- Use the Design Code and your own studies to understand what is important to conserve, what new development can learn from the past, and what the priorities for change are in the local area, before considering how to address these in your design proposals.
- Design for longevity, adaptability, ease of maintenance and to make a long-term contribution to the places of Spelthorne.
- Reflect key characteristics such as building grain, roofscapes, detailing and building lines, and avoid abrupt changes in character without a gradual transition between existing and new.
- Spelthorne's historic development is strongly tied to the desire for healthy urban living, being connected to both city and nature. New development should continue to enhance this approach, with usable, accessible and welcoming green open spaces.
- Make connections to the rivers of Spelthorne for both people and nature, and provide a range of green open spaces for new and existing residents to improve provision for all.
- Respect and retain riverside settings that provide amenity, placemaking and functional benefits.
- Make streets green spaces with trees and planting to provide shade and access to nature.



Connectivity

Enhance access to and the quality of public transport links, and improve the quality and safety of routes for pedestrians and cyclists.



Strong, Mixed Communities

Create inclusive places and spaces that cater to all, using design to physically and socially unite existing and new communities.



Climate Change Resilience

Mitigate the impact of development and adapt to varied risks that may be worsened by climate change, through thoughtful design and natural solutions, that can also enhance the quality of open spaces for people and nature.

- Create streets and enhance existing streets that reduce car dominance and prioritise active travel movement, particularly major arterial roads and town centre roads.
- Include supporting facilities such as cycle hubs, cycle parking, seating, water refill points
- Daily uses should be within walking distance of all homes, and all uses designed so that they can co-exist with each other, especially in Spelthorne's town centres.
- Encourage the use of riversides for walking, cycling, leisure and recreation
- Create connections between existing and new neighbourhoods
- Enhance the spaces around, and connections to railway stations

- Create healthy spaces for people, that encourage the development of a community and a range of social interaction.
- New development should feel part of the surrounding area, and encourage social interaction
- Homes and buildings should be adaptable for the future, and reflect the diversity of living needs of Spelthorne's existing and new communities. They should be practical, with enough storage and outdoor amenity space for modern living.
- Ensure all public space is safe, comfortable and secure for all.

- Reuse and refurbish existing buildings first where this will reduce lifetime carbon emissions
- Use natural and sustainable design solutions to manage increased intensity of surface water flooding events
- Seek betterment for surrounding areas where possible through the replacement of existing impermeable surfaces with more permeable materials and planting, reducing flood risk and contamination from runoff
- Design drainage features that can be managed and maintained over the long term
- Use a diverse and robust mix of native species in planting that can withstand changes in climatic conditions



The Design Process

- » The Role of Design in the Planning Process
- » Approach
- » Key Steps

The Design Process

The Role of Design in the Planning Process

The National Planning Policy Framework (NPPF) sets out the importance of design within the planning process to achieving the goal of high quality, beautiful and sustainable buildings and places. Key to this is a common understanding of design expectations, with design guides or design codes being a vital tool that all local planning authorities should prepare.

Design within the planning process is considered within the framework established by the National Design Guide (2019).

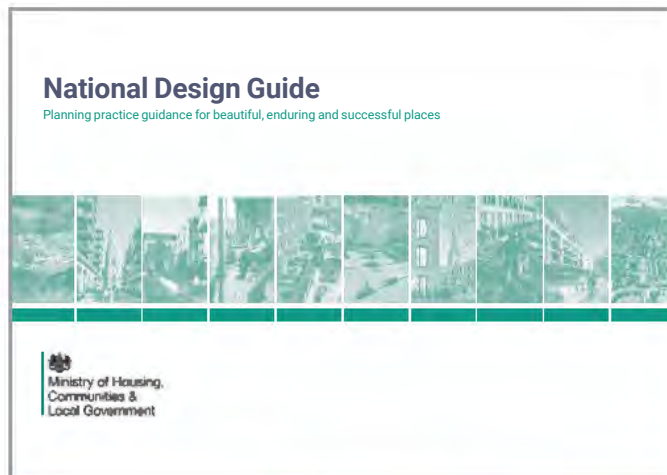

Locally-specific design codes, prepared through a process of effective community engagement such as the Spelthorne Design Code, should take into account the guidance set out in the National Model Design Code, which is based on the framework of the ten characteristics established in the National Design Guide.

The Spelthorne Design Code has been prepared in line with the National Model Design Code's guidance, and makes reference throughout to the ten characteristics of well-designed places.

Design coding is one tool available to ensure high design quality. The NPPF recognises the importance of other tools and methods available to support a good design process. Early engagement between applicants, the community and the local authority is supported and will lead to more successful design outcomes.



Approach

No two sites or proposals are the same, and the design process for each will vary depending on circumstances. Larger, more complex sites with more ambitious proposals will require more design thinking than smaller, simpler proposals.

Design is an iterative process – you may not get the right answer on the first try! There may be multiple ways of addressing an issue or opportunity, and many different competing requirements by different stakeholders. Use of community engagement and the council's pre-application services are encouraged to help you find the optimum solution.

However, there are a number of guiding principles to an effective design process within the planning system, that should be followed by all applicants. This section sets out those key principles. The following section on Key Steps sets out how to practically undertake an effective process, and how to integrate it within the planning application process.

All designs should be inspired first by **learning about the place and its wider context**. The Design Code sets out key information about each of the places and area types within the borough for context, and the 'Understanding Spelthorne Today' appendix provides a further, deeper understanding of place. This information should be supplemented by site visits, research, community engagement and analysis.

Think about **who you are designing for** to ensure that places are inclusive and work well for all. Different social and ethnic groups, genders, ages, abilities and other characteristics all use and experience the built environment in different ways. This can be particularly important in ensuring that places feel safe, secure and welcoming to all.

Appropriate engagement should run throughout the process, with technical stakeholders, the community and the local authority. The **right engagement at the right time** can inform and influence design proposals to be better and widely supported by all stakeholders. Good engagement should seek to build consensus and help applicants to learn from the existing and potential new community that they seek to serve.

Be **opportunity-led and positive** with proposals. Mitigating any potential harm is important, but needs to be balanced against maximising the opportunity present on a site.

Environmental sustainability should be woven throughout all design, with the expectation that development in Spelthorne is of high standards in climate change mitigation and adaptation, sustainable water management, green infrastructure and biodiversity. The Climate Change Supplementary Planning Document sets out design approaches and a design checklist.

A strong design brief and process starts with testing whether the **reuse and refurbishment of existing assets** is feasible. Re-use of existing buildings can both reduce embodied carbon emissions from construction of new buildings, but also retain the existing character and heritage of a place.

The built environment can have a significant impact on the **health and wellbeing** of its users. The creation of places that can help people to live physically active and mentally stimulating lives is of vital importance. This includes ensuring physical accessibility for all ages, prioritising active travel, making homes and buildings adaptable for all stages of life, and considering how neurodivergence needs can affect people using the public realm. It also extends to mental wellbeing: ensuring that people can meet, interact, and also relax in safety and comfort.

Often, the **details matter**, even at an early stage of design. This can be particularly important if there are key technical constraints that need to be overcome to deliver a scheme, which should be tested early in the process. It can also be important in engaging the community, where what is important to them may be quite specific.

All open spaces should have a clear and well-defined use carried through their design, which should be set out in the design proposal. **Landscape design input should be integrated** into the overall design process for a site, and should be able to influence the built form as it relates to open spaces. Landscape and open space design, when considered as a holistic part of the design of schemes, can have a significant impact on the quality and success of new development.

When considering details and **architectural style**, this can take a number of forms that may be appropriate to the context. The Design Code sets out key parameters for different area types but does not prescribe architectural styles, which should be considered carefully by applicants and design teams, as it may be an area of particular interest to the local community. The architectural style and language chosen should be applied consistently. Considerations for different architectural approaches are set out in the diagram to the right. It is also possible, with a degree of design sophistication and subtlety, to blend different approaches in a transitional approach where this suits the context, picking up and re-interpreting key vernacular or traditional contextual characteristics in a modern way.

Design teams should anticipate what aspects of their proposals will need ongoing **stewardship and management**. This may be as simple as ensuring that there is accessible and sufficient storage for facilities management, or designing to ensure that highways, drainage and open space can be adopted by the local authority, through to working with wider teams to ensure long-term management financial arrangements are put in place for buildings and spaces.

Explaining your proposals to stakeholders, the community and as part of your application can make a huge difference in how they are received, and also in reaching clarity in design thinking. A wide range of **graphical communication techniques** are available which should be employed at various stages. Hand-drawn sketches can be helpful early on in exploring ideas, before resolving to detailed plans and computer-generated visualisations.



TRADITIONAL

Reflects existing buildings and architectural vernacular, often with more detailing.

Well-suited to areas of heritage significance.

Can be unimaginative or risk pastiche if executed poorly.



CONTEMPORARY

Simpler architecture that is clear about the period in which it is built, with simpler detailing although retaining texture.

Efficient to design and construct.

Can lack connection to context if not executed well.



INNOVATIVE

Unusual, eye-catching and experimental.

Creative, interesting and can advance what is possible.

Requires high degree of design sophistication for success.



A scale of potential architectural design approaches with examples showing different applications of the approach to recent development in England.

Key Steps

An effective design process should demonstrate (as part of its submission materials within the Design & Access Statement) that it has undertaken the following key steps. They should be undertaken and supported with studies at an appropriate level of detail for the scale and context of the proposal.

Step 0: Setting the brief and appointing the team

The most important step in a good design process is the creation of a flexible, design-led project brief that responds to all planning policy, national legislation, the site and its context. This should set key parameters and expectations but also allow flexibility for change once design teams have had a chance to assess the site for capacity and potential.

As part of setting a brief, on larger proposals applicants will need to put together a specialist team appropriate to the project, with a strong design background, and all skills involved from an early stage. A co-ordinating lead will need to be put in place to ensure that trade-offs and decisions between different priorities are handled consistently and in line with the project brief. All disciplines should be involved in regular multi-disciplinary sessions to ensure that technical and other inputs into the design process are heard and considered throughout the process.



Example of a site analysis plan highlighting the most important spatial features of a site and its surrounding context. These key features should influence the resulting design.

Step 1: Understanding the site and context

A full understanding of the site from a range of perspectives is vital for developing high-quality proposals that respond properly to the context and needs of the site. This should include as a minimum an understanding of the site and local context in relation to the following themes:

Environmental and Physical Constraints:

- Water and flood issues, including surface water, fluvial flood risk and groundwater issues
- Existing Utilities
- Protected Habitats and Ecology
- Existing Green Infrastructure
- Noise, Air Quality, Contamination

Heritage, Context and Placemaking:

- Heritage Assets
- Built form and urban typologies
- Heights, floor area ratios, grain and key dimensions
- Historic mapping and street patterns
- Land uses
- Connectivity and Mobility:
- Active travel and public transport connectivity
- Street hierarchy

As part of this understanding and analysis process, community engagement is a vital tool to learn more about a place, its context and local ambitions or priorities. This can take a number of forms from informal meetings, to drop-in events and co-design workshops.

Designers are encouraged to look beyond the boundary of the site and consider how their proposals will fit within the wider context. This may help inform where key uses, streets, open spaces and built form are located more effectively than looking at a site in isolation. Drawings will be expected to include an appropriate level of contextual information on them.

Step 2: The Vision

A clear vision of what the future development will be is a vital tool to keep projects on track and delivering on their promise. This could include a vision of character, function and what it might do for the existing and new community. Effective design visions are often backed up by a coherent narrative and effective, engaging concept diagrams, making reference to the surrounding context.

Community engagement to co-develop and test visions can be an important part of this step, establishing a shared approach to a site from the outset, in line with the Design Code.

Step 3: Developing and Testing Options

Design options to achieve the design vision should be prepared and explored iteratively. This will typically initially focus on massing, location of key uses, broad spatial arrangement of open spaces and relationships with surrounding areas.

Options testing through community engagement and with technical stakeholders can be a valuable part of the design process, helping everyone become involved before decisions are fixed.

Options should be appraised against the design vision, the Design Code, planning policy, their ability to achieve site opportunities, priorities learnt from community engagement and the wider brief. Engagement with the local authority through the pre-application process is encouraged.

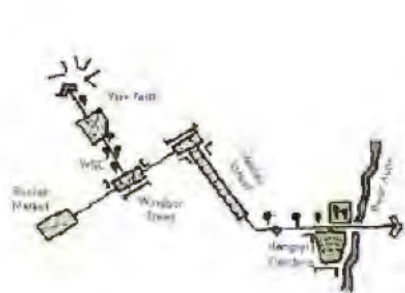

Extending a sequence of pedestrian friendly spaces



Creating a new pedestrian route through the site and improving permeability

Example of concept diagrams showing clearly the key structuring elements that drive the design, and why



Example options testing for a site, exploring different approaches to retaining/replacing buildings and the resulting layout changes needed.

Step 4: Site Parameters

Once a preferred option is chosen, key site parameters such as the built form envelope, access, green infrastructure and open spaces should be established and communicated through the design team, to form a basis for further work and design development. These parameters could be agreed with the council through the pre-application process, or even through an outline planning application. A site-specific Design Code may need to be prepared to guide future design teams.

Further community engagement at this stage can explain why and how this option has been chosen, and how community involvement has helped to influence this.



Example storey heights parameter plan

Step 5: Resolving the Details

For a full or reserved matters application, design teams will then begin to resolve details such as façades, materials, detailed landscape and public realm proposals and other matters. These should be within the parameters established earlier, especially if those parameters have been agreed as part of an outline planning application or other method.

At this stage more complete visualisations may help the community to understand a scheme, its materials, architectural treatments and façades, and landscape proposals.



Find out more background information about the borough in Appendix A 'Understanding Spelthorne Today'.



Example visualisation for a residential street. clearly demonstrating proposed character and use



Places Past, Present and Future

- » Staines-upon-Thames
- » Ashford
- » Sunbury-on-Thames
- » Shepperton
- » Stanwell
- » The Villages

Staines-upon-Thames

Staines-upon-Thames is the largest town of the borough, a market town on the River Thames in the northwest of Spelthorne. Historically known simply as Staines (being renamed in 2012), the town is the largest in Spelthorne with the largest shopping area, key facilities and a growing population.



PAST

The location of Staines is likely to have originated from the position of a Roman bridge across the Thames. The earliest records of Staines as a settlement are from the town's first market, held in 1218. Construction of the current Staines bridge was completed in 1832 representing the first major development since medieval times; substantially changing the town's street pattern to accommodate the new bridge location.

The arrival of the railway in 1848 stimulated growth of the town, including residential development along London Road and Kingston Road. In 1864, the Hale Mill linoleum factory opened, becoming a key economic driver to the town and occupying up to 20 hectares of land at its height in the 1920s.

The town grew southeast in the early to mid-20th century, with widespread construction of suburban semi-detached housing which remains today. Some of the post-WWII housing was built specifically to accommodate Heathrow Airport workers, as the airport rapidly expanded.

Later 20th century development was increasingly car-oriented, and infrastructure projects included construction of the A30 bypass in the 1960s. The Elmsleigh Shopping Centre opened in 1980, along with a multi-storey car park. The closure of the Hale Mills linoleum plant in 1973 opened up availability of this site which was redeveloped in the late 1990s to become the Two Rivers Shopping Centre, along with large swathes of surface-level car parking.



1880



1934



1970

PRESENT

Today's urban form of Staines town centre is heavily influenced by 20th century car-oriented development, resulting in large block forms comprising shopping centres, office blocks, logistics and warehousing uses. The four-lane A308 road (Clarence Street / Thames Street) adds to the centre's car dominance, causing severance between the High Street and the Market Square. In contrast to these modern additions to the town, the High Street contains many smaller older buildings, providing a more traditional town centre character. The High Street has also been pedestrianised, improving the pedestrian experience.

Notable buildings in the town include the Renaissance style Town Hall built in 1880. Also, a large vacant department store building (formerly Debenhams) is located on the corner of the High Street and Thames Street (A308). Twenty-first century development includes the two towers (15 and 13 stories) currently being constructed on the former Masonic Hall and Telephone Exchange sites, representing some of the highest site densities in the borough to date.

In contrast, Church Street (west of the centre) has retained a distinct 'village' character despite its close proximity to 20th and 21st century developments. A fine urban grain, mixture of building types, and proximity to the Grade II* listed St Marys Church and cemetery provide a rural village feel.

A large part of Staines is protected through Conservation Area status, extending along the bank of the Thames to include St Mary's Church in the northeast, Church Street, Bridge Street, and Clarence Street. This covers the Market Square (with town hall), the entrance to the High Street, and the (currently vacant) department store building on Thames Street.

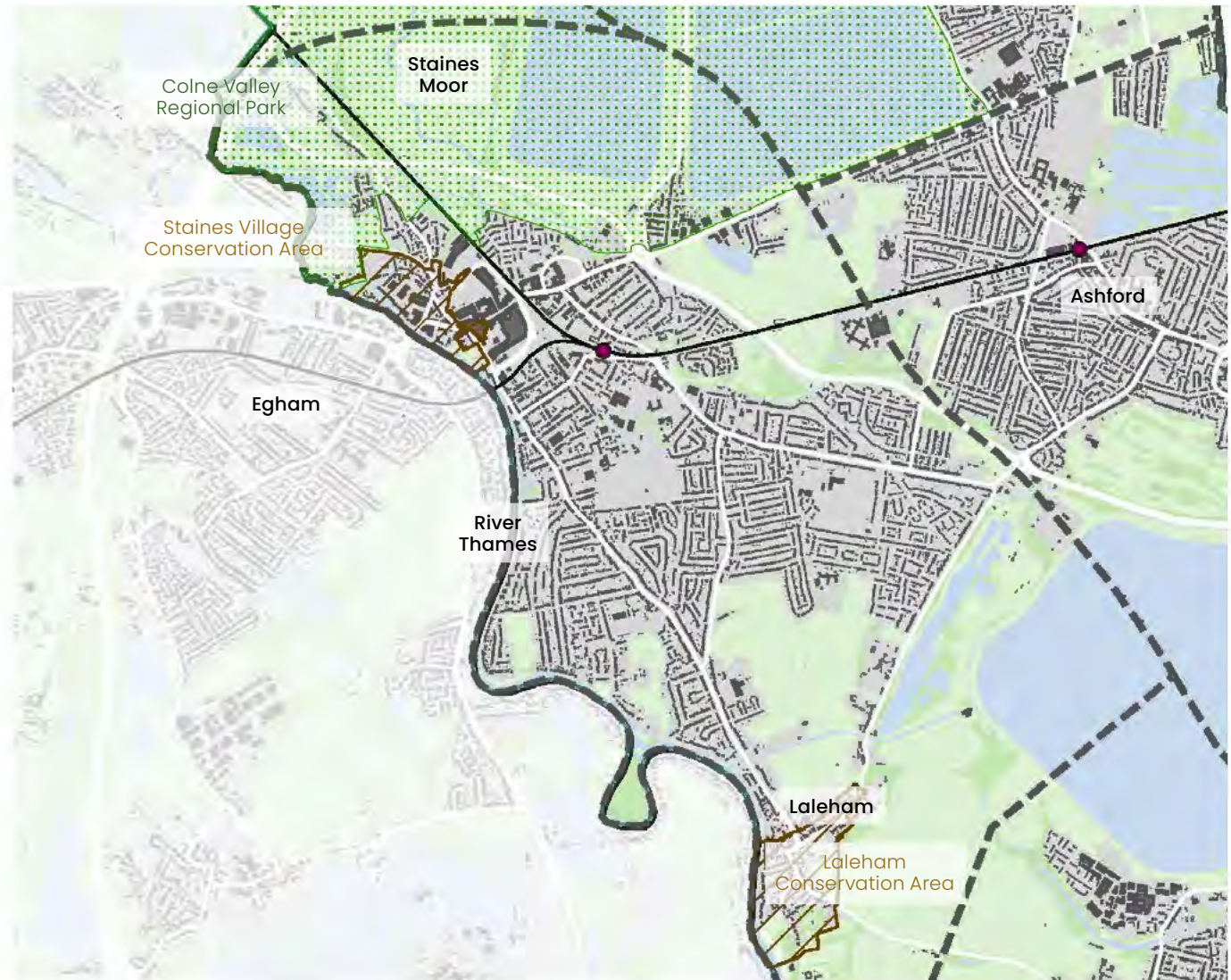

The remainder of Staines comprises largely of suburban dwellings from a range of eras; from typical 1930s semi's through to more modern, 1990s cluster-style residential layouts. The predominant housing layout in the older, southeastern part of Staines is typically regular and linear.

Staines has strong connections to surrounding green spaces, including the Colne Valley Regional Park, Staines Moor and Shortwood Common.

 **Find out more** background information about the borough in Appendix A 'Understanding Spelthorne Today'.

The Design Vision & Principles for Change

Staines-upon-Thames will be an inclusive, well-connected urban centre with improved riverside access, better design, and flood mitigation. Key priorities include balancing heritage, enhancing connectivity, and transforming the area into a modern, safe town with green spaces and a public riverfront.

DESIGN PRINCIPLES



Sustainable Urban Design

- Conserve the street-level and townscape experience of areas with strong place identity
- Create new town centre neighbourhoods that are integrated with their surroundings and improve the townscape of the area



Commitment and Connections to Green Space

- Improve connections to the rivers, physically and visually, with improved safety and quality of spaces adjacent to the Thames
- Create new urban public open spaces to enhance the town centre



Connectivity

- Create new walking and cycling connections through new town centre neighbourhoods
- Improve the safety and security of existing paths and cycle routes



Strong, Mixed Communities

- Development that integrates new residents into the existing community, through physical links and new shared infrastructure and facilities
- Improve safety in public spaces



Climate Change Resilience

- Improve surface water permeability by converting impermeable hard surfaces to softer, permeable and planted spaces
- New development must not worsen fluvial, surface water or groundwater* flood risks

WHERE DID THIS COME FROM?

The Vision for the future and Principles for change were developed by the Spelthorne Design Code Citizens Panel and wider community through the engagement process.

* Research paper on groundwater flooding in Staines – [Paul, J.D. et al. \(2025\) 'Groundwater flooding of superficial gravels in an urbanized catchment,' Journal of Flood Risk Management, 18\(2\)](#). This academic paper was not commissioned by Spelthorne Borough Council.

Ashford

Ashford is a large town located centrally within Spelthorne. The town is predominantly suburban with a high proportion of semi-detached homes. Ashford has a well-used high street (Church Road), a railway station, and several local / neighbourhood centres spread throughout the suburban area.



PAST

Ashford was originally recorded as Exeforde on the Middlesex Domesday map. The land was held by Robert, Count of Mortain, a half-brother to William the Conqueror.

The modern-day name of Ashford derives from a crossing point over the River Ash. In 1789, this crossing was upgraded to a stone bridge by the Hampton and Staines Turnpike Trust. Today, the river is located to the south of Ashford meandering north of Staines bypass and passing under Fordbridge Roundabout.

Before the 19th century, Ashford Common was a large area of common land found in the south and east of the town. This was used during the reign of King George III for British military displays. Public rights were removed from this land in 1809 through the Inclosure Act, and much of the land is now developed.

In 1902, Ashford Manor Golf Club was established within Ashford's manorial estate. In the same year, the construction of Staines Reservoir was completed. In 1924, construction of the Queen Mary Reservoir was completed. At the time, it was the largest reservoir in the world. The reservoir was used to test submersibles during World War II.



PRESENT

Ashford's land use is largely suburban residential. The predominant housing type is low-rise detached and semi-detached; mainly built between 1885 and 1960. A recent development north of Church Road introduces some higher densities with apartment blocks up to five stories high.

The town centre is predominantly linear in form along Church Road, extending east-west from St Matthew's Parish Church to Ashford railway station. The centre includes a wide range of shops and services including several convenience stores, takeaways, coffee shops, hairdressers, health & beauty salons, a library and a bank.

Ashford includes eight primary schools and two secondary schools. Ashford Hospital is located northwest of the A30 London Road, providing mostly day surgical and outpatients services. The prison HMP Bronzefield is also located on the edge of Ashford. This is the largest female prison in Europe.

Ashford includes several churches, including CofE churches St Matthew's (Church Road) and St Hilda's (Woodthorpe Road); and Roman Catholic church St Michael's (Fordbridge Road). The latter was designed by Sir Giles Gilbert Scott in a distinctive Romanesque Revival style, built in several stages between 1927 and 1960.

Access to green space in Ashford is limited to several relatively small green areas. These include Hengrove Park, Woodthorpe Road Play Area, Ashford Recreation Ground, and Feltham Hill Road Recreation Ground. Notably, Ashford Manor Golf Club constitutes a large proportion of the overall green space; however, this is not publicly accessible.

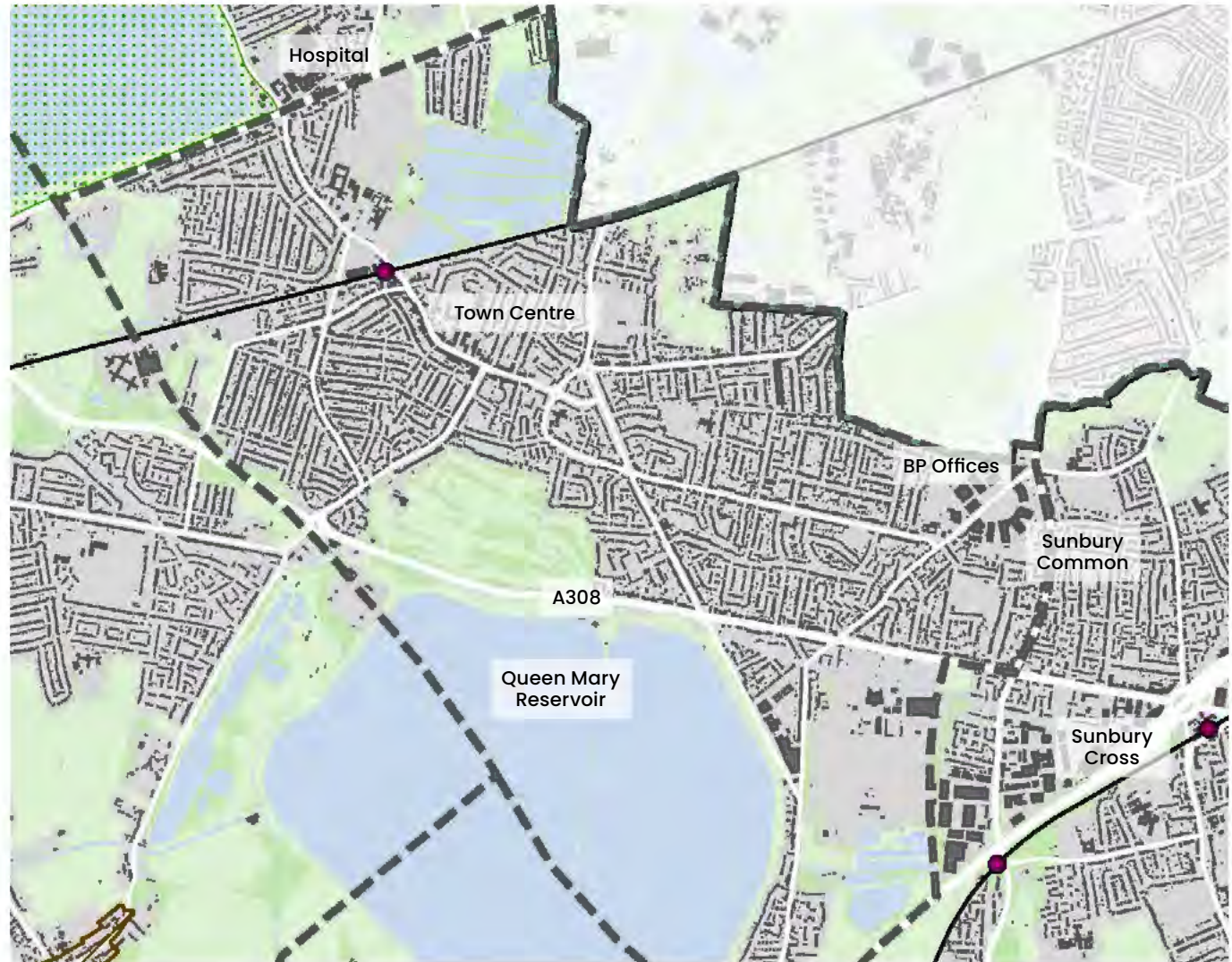

Find out more background information about the borough in Appendix A 'Understanding Spelthorne Today'.

The Design Vision & Principles for Change

Ashford will be a safe, community-focused area with green spaces, a revitalised High Street, local parks, and minimal high-rise development. Community feedback emphasises keeping Ashford family-friendly with a focus on youth and vibrant public spaces.

DESIGN PRINCIPLES



Sustainable Urban Design

- Prioritise apartment development close to public transport and main streets
- A wide mix of different types of homes in new development, that integrate well and are inspired by the existing character of the town



Commitment and Connections to Green Space

- Trees, planting and/or street greening throughout the High Street, major roads and all public realm



Connectivity

- Improve walking and cycling space, especially around the High Street and station
- Successful car parking arrangements that do not add to the car dominance of streets
- Improve public realm around the station



Strong, Mixed Communities

- Include space for local independent businesses as a core part of the appeal and vibrancy of the town centre
- Improve safety in public spaces



Climate Change Resilience

- Improve surface water permeability by converting impermeable hard surfaces to softer, permeable and planted spaces
- Create more shade and cooling in streets and open spaces

WHERE DID THIS COME FROM?

The Vision for the future and Principles for change were developed by the Spelthorne Design Code Citizens Panel and wider community through the engagement process.

Sunbury-on-Thames

Sunbury-on-Thames is located in the east of Spelthorne Borough. It has a number of distinct areas including Lower Sunbury, Sunbury Common and the Sunbury Cross shopping centre. Sunbury is well provisioned with open green spaces, schools, shops and services. Sunbury train station provides direct services to central London. The town is divided by the M3 motorway.



PAST

The name 'Sunbury' has an unclear origin with variations of the name included in two Anglo-Saxon charters and the later Domesday Book of 1086.

An important early development was Sunbury Park located close to the River Thames, being the site of a Tudor Manor House built for a courtier of Elizabeth I. The area along the river became a gentrified area with many large properties built by wealthy residents. These included a group of Huguenot refugees, and it is possible that French Street is named after these settlers.

Sunbury was historically based around this area. To the north, Sunbury Cross is an historic intersection of five main roads, along with

scattered/linear development along Green Street connecting to the River Thames. Until the railway arrived in Sunbury in 1864, the wider area was mainly open fields and common land. Much development took place in the interwar and post-war periods, developing Sunbury Common into a suburb with a predominance of detached and semi-detached homes.

Significant change took place in Sunbury Cross during the 1970s with the construction of the M3 junction, and of several high-rise buildings and the Sunbury Cross shopping centre.



1880



1934



1970

PRESENT

Sunbury's land use is predominantly suburban residential, with some urban areas and industrial areas. To the northwest this includes the British Petroleum (BP) International Centre for Business & Technology, a research and office campus.

Sunbury Cross has a more urban development form with several high-rise buildings and a shopping centre. There are a range of shops, fast food outlets, health & beauty services, convenience stores, supermarkets, and a Premier Inn hotel. Community buildings include a library and church.

There are a range of green spaces across Sunbury including Meadhurst Sports Ground, Groveley Road Recreation Ground, Kenyngton Manor Recreation Ground, Cedars Recreational Ground, Sunbury Park, and Lower Hampton Road Park. Sporting venues include the Gaflac Sports Ground, Kempton Cricket Club, Sunbury Cricket Club and Sunbury Sports Bowls Club. Adjacent to the east of Sunbury is also Kempton Park Racecourse, an 85-hectare site with equestrian racecourse involving adjoining inner and outer courses for flat and National Hunt racing.

Lower Sunbury, along the River Thames, has a contrasting 'village' feel compared to the wider area, with a range of historical properties, a finer urban grain, and adjacency to the historic Sunbury Park. Some of this area has Conservation Area status, incorporating much of Thames Street, Church Street, Sunbury Court, and part of French Street. While the manor house of Sunbury Park was demolished in post-war years, the parkland and walled gardens remain and add to the historic character of the area.

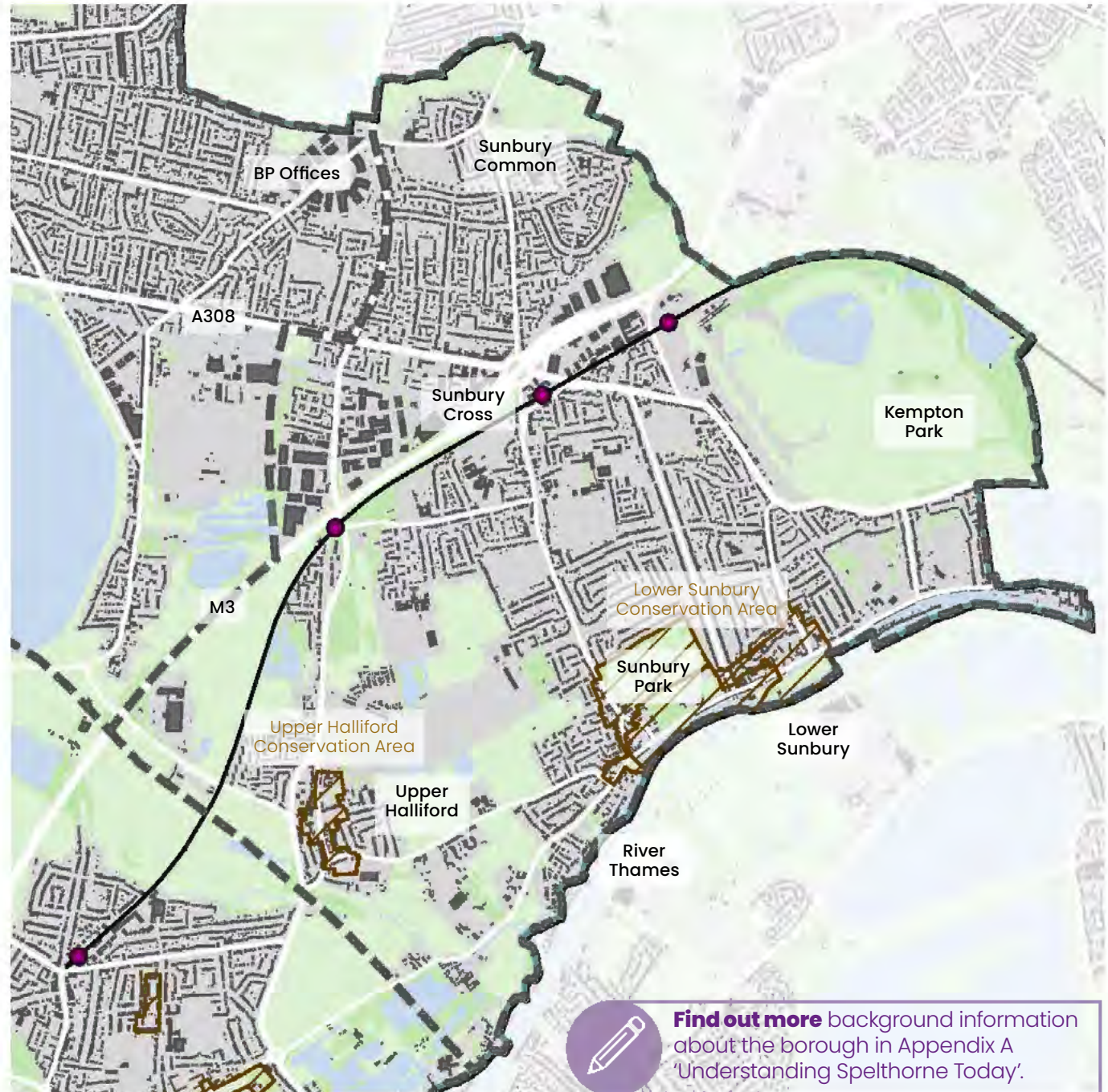

The Design Vision & Principles for Change

The different areas of **Sunbury-on-Thames** will maintain their distinctive and varied characters and a comfortable, well-designed environment with ample common spaces, reduced congestion and a welcoming atmosphere. Key priorities include improving accessibility for all, particularly those with reduced mobility. **Sunbury Cross** will become a safer, more human-scale place for residents and visitors, with reduced impact from vehicles, and reduced severance caused by infrastructure.

DESIGN PRINCIPLES



Sustainable Urban Design

- Prioritise apartment development close to public transport and main streets
- Built form that creates human-scale environments with improved safety
- Ensure sensitive intensification of existing suburban areas



Commitment and Connections to Green Space

- Trees, planting and/or street greening throughout major roads and all public realm
- Reflect existing 'green' and verdant characters
- New well-maintained green spaces that are designed positively



Connectivity

- Reduce severance caused by infrastructure
- Improve walking and cycling provision in streets and to the rail station
- Reduce the dominance of cars in the streets
- Enhance walking and cycling connections to, from and along the River Thames
- Improve public realm around the station



Strong, Mixed Communities

- Improve safety in public spaces
- Include a wide mix of homes, supported by community facilities



Climate Change Resilience

- Improve surface water permeability by converting impermeable hard surfaces to softer, permeable and planted spaces
- Create more shade and cooling in streets and open spaces

WHERE DID THIS COME FROM?

The Vision for the future and Principles for change were developed by the Spelthorne Design Code Citizens Panel and wider community through the engagement process.

Shepperton

The village of Shepperton is located to the south of the borough, characterised by a thriving high street and many attractive tree-lined residential streets. Shepperton can be divided into two distinct areas with the main built-up area to the north, and Old Shepperton to the south. The town includes various shops and cafés, as well as a railway station providing direct trains to London Waterloo.

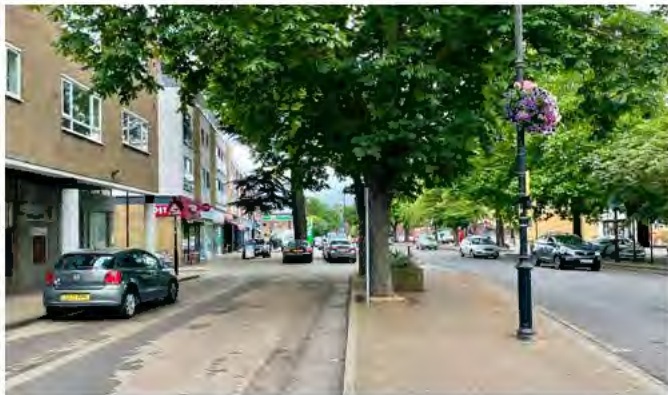

PAST

There is evidence of human activity in Shepperton since the middle-Neolithic period, from the discovery of a penannular ring ditch in the 1980s. In 1086, the Domesday Book recorded a population of 25 households in Shepperton (then referred to as 'Scepertone').

Shepperton is strategically located nearby the River Thames which has been a vital transport route since the late 13th century. Products including grain, vegetables, and building materials were transported by the river. To aid river navigation, Shepperton Lock and Sunbury Lock were built near Shepperton in the 1810s.

Shepperton originally developed as a settlement on the River Thames; the area known as Old

Shepperton today. Church Square in Old Shepperton served as the original settlement nucleus. The square has a range of historic buildings, most notably the St Nicholas Parish Church, built in 1614. Sir Nikolaus Pevsner described the square, with its glimpse of the River Thames, as "one of the most perfect village pictures that the area has to offer".

The construction of the Shepperton branch line in 1864 led to a new focus of development away from the existing village and 1 mile to the north where Shepperton station had been constructed. This led to the formation of Shepperton town, connecting south to Old Shepperton via the high street and Church Road.



1880



1934

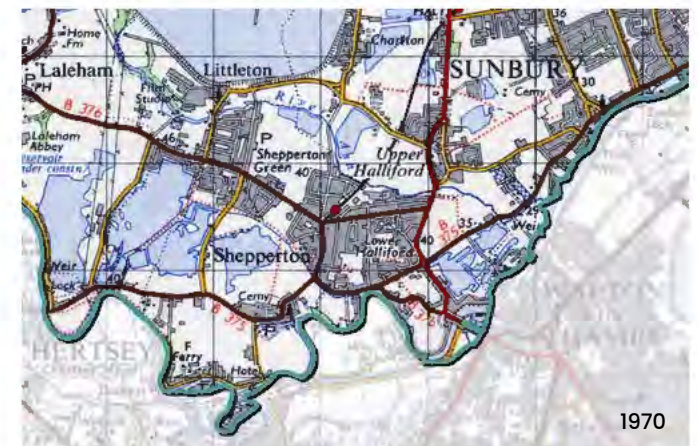

1970

PRESENT

Shepperton's high street is a thriving centre with a wide range of shops and cafés, including independent businesses. The high street is a wide road with parking roads either side. However, there is a good sense of enclosure owing to the mature trees which line the street. There is a large mix of land uses including housing, offices, a library and a church; adding to the vibrancy of the area.

The residential areas in Shepperton are suburban developments mostly constructed in a linear pattern. Houses are mostly detached and semi-detached, along tree-lined streets. Broadlands Avenue is an attractive area with generous plot sizes and large, detached houses.

Shepperton includes three conservation areas: Old Shepperton, Lower Halliford, and the Manygate Lane estate. Old Shepperton includes several historic buildings such as the parish church, two public houses, an 18th century riverside manor, and a Grade II* listed timber framed Old Rectory building built c.1500. Lower Halliford includes several detached classical 18th century riverside houses, and the meadow along Russell Road. The Manygate Lane estate is a contrasting modernist development characterised by modular rectangular, white-painted houses from the mid-20th century.

There are several accessible green spaces in Shepperton, including Shepperton Recreation Ground and Manor Park. Unlike other areas in Spelthorne, Shepperton has close proximity to surrounding fields and rural areas, as well as Public Rights of Way providing a variety of walking routes.

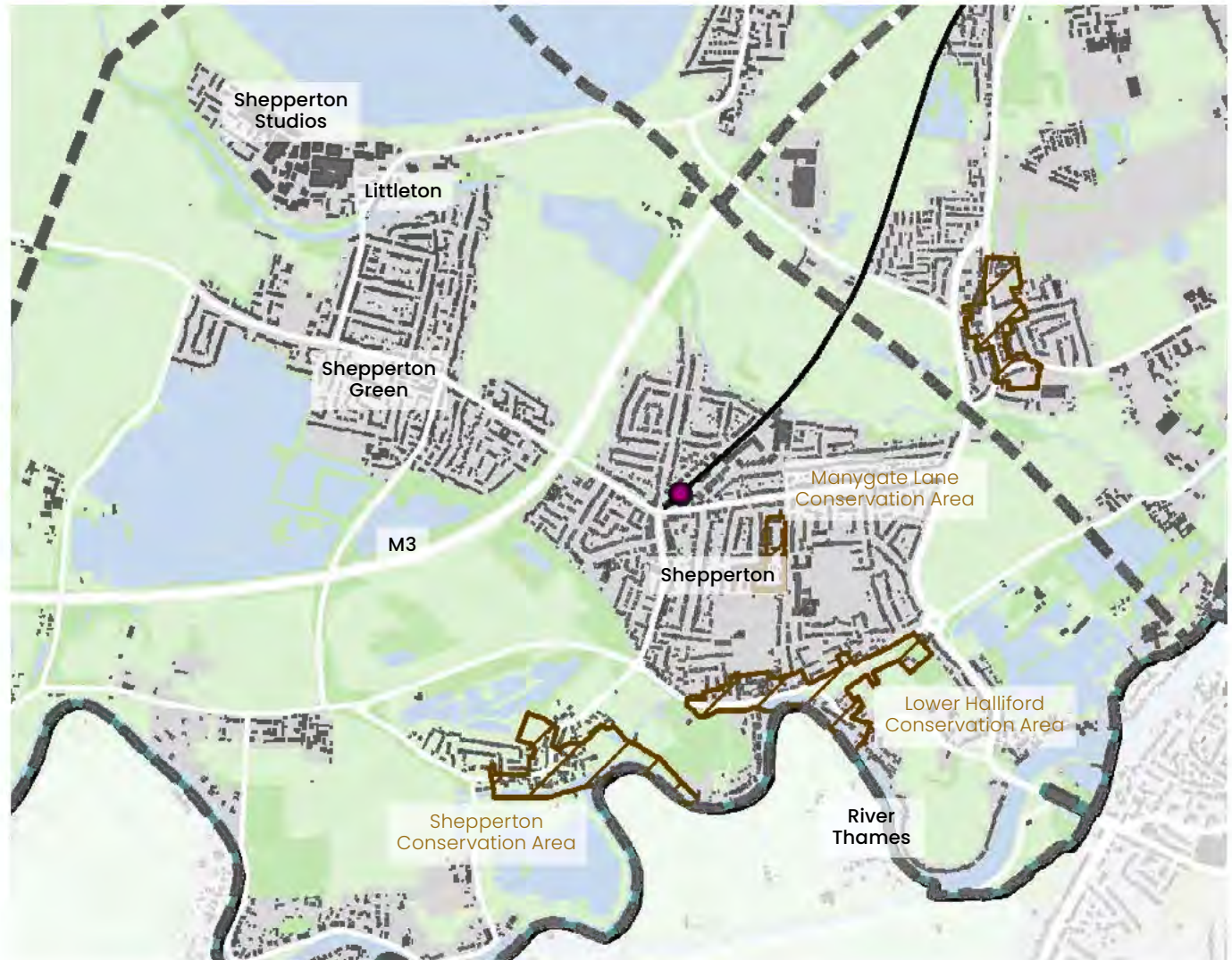

Find out more background information about the borough in Appendix A 'Understanding Spelthorne Today'.

The Design Vision & Principles for Change

Shepperton will preserve its village charm while embracing well-designed new development. The community supports a new square in the centre, better cycling infrastructure along the Thames, and a semi-pedestrianised High Street that retains independent shops while supporting sustainable growth and transport.

DESIGN PRINCIPLES



Sustainable Urban Design

- Ensure sensitive intensification of existing suburban areas reflects the existing street scene and architecture



Connectivity

- Improve walking and cycling provision in streets and to the rail station
- Reduce the dominance of cars and highway infrastructure in the streets



Climate Change Resilience

- Improve surface water permeability by converting existing impermeable hard surfaces to softer, permeable and planted spaces



Commitment and Connections to Green Space

- Reflect the existing 'green' and verdant character of the place
- Include planting, seating and high quality materials throughout the public realm



Strong, Mixed Communities

- Improve safety in public spaces
- Include a wide mix of homes, supported by community facilities

WHERE DID THIS COME FROM?

The Vision for the future and Principles for change were developed by the Spelthorne Design Code Citizens Panel and wider community through the engagement process.

Stanwell

Stanwell is a predominantly residential suburban area in the north of Spelthorne Borough, located east and northeast of the Staines Reservoirs. It is the northernmost settlement in Surrey. There is a small village centre to the north of Stanwell, with a village green, pub, church, and small range of shops and services. Stanwell is in close proximity to Heathrow Airport to the north.



PAST

The Domesday book of 1086 records 'Stanwelle', unusually retained by a man with an Anglo-Saxon name. In 1603, the manor of Stanwell was granted to Thomas Knyvet who helped to foil the attempt of Guy Fawkes to blow up the Houses of Parliament. Up until the 20th century the area was mainly farmland and moor land surrounding the village of Stanwell.

The extent of Stanwell was cut substantially during the 20th century with the construction of the Staines Reservoirs in 1902 and the development of Heathrow Airport (originally Harmondsworth Aerodrome) which became operational in 1930. Additionally, some land was taken west of Stanwell Moor for the construction of the M25 in the 1980s.

Large-scale construction of new homes began following World War II. Over 300 prefabricated houses were built between Town Lane and Long Lane between 1945 and 1948. Several smaller developments of terraced and semi-detached houses, including those either side of Park Road, were built since 1954 by the British Airways Staff Housing Society.



PRESENT

The suburban residential areas today comprise largely of semi-detached and terraced housing built between the 1950s to 1970s, with some early 21st century development. The urban form involves regular perimeter blocks with areas of green space distributed throughout the development.

The historic centre of Stanwell, a Conservation Area, retains a distinctive village feel from the surrounding 20th century suburban development. The urban form is nucleated, with St Mary the Virgin Church and the village serving as focal points. A variety of historic properties from different time periods adds to the village character. The centre benefits from several shops and services including a convenience store, public house, a range of takeaways and a florist.

The wider area of Stanwell also includes Stanwell Moor, a distinct settlement located north of King George VI Reservoir. Residential properties are predominantly from the mid-to-late 20th century. Stanwell Moor offers several facilities including a village hall, parade of shops, and public house.

There is a good provision of green space throughout Stanwell. This includes Village Park, Lauser Road Park, West Bedfont playing fields, Clyde Road Park, and Stanwell Moor playing fields. The wider Stanwell Moor and areas within the Colne Valley Regional Park have future potential for improved access.

While Stanwell is in close proximity to Heathrow Airport, there is limited access between the settlement and the airport due to the perimeter road and adjacent watercourses. In January 2025, the government invited Heathrow Airport to bring forward proposals for a third runway. While details of the proposed airport expansion are not yet known, these plans have the potential to impact the future character of Stanwell.



Find out more background information about the borough in Appendix A 'Understanding Spelthorne Today'.

The Design Vision & Principles for Change

Stanwell will develop a clearer place identity and have better integration with the rest of Spelthorne. Development should focus on addressing infrastructure gaps, prioritise healthy placemaking and create more connected spaces, both green and built, to foster community cohesion and opportunity.

DESIGN PRINCIPLES



Sustainable Urban Design

- Ensure that edges between different land uses successfully manage any impacts from one use to another
- Create places that have sufficient density to be vibrant, sustainable and safe



Connectivity

- Enhance walking and cycling connections to existing streets and the wider context, including Heathrow and employment areas
- Improve the safety, security and attractiveness of existing links



Climate Change Resilience

- Improve surface water permeability by converting impermeable hard surfaces to softer, permeable and planted spaces
- Create more shade and cooling in streets and open spaces



Commitment and Connections to Green Space

- Extend and enhance existing green spaces, with green corridors into new development
- Create new green spaces that can host community events and become places to meet, socialise and relax



Strong, Mixed Communities

- Prioritise health and wellbeing as a key design driver for new development
- Improve safety in public spaces
- Include a wide mix of homes, supported by community facilities

WHERE DID THIS COME FROM?

The Vision for the future and Principles for change were developed by the Spelthorne Design Code Citizens Panel and wider community through the engagement process.

The Villages

As well as the main settlements, Spelthorne has a number of smaller villages such as Stanwell Moor, Laleham, and Upper and Lower Halliford.

Although varied, many of these villages have common characteristics and forms derived from their traditional Middlesex character and relationship to agriculture.

The character of these villages is often defined by the historic core, and is usually a combination of the built form, street design, open spaces and landscape.

Any development or change in villages will strongly reflect the surrounding context and built form.

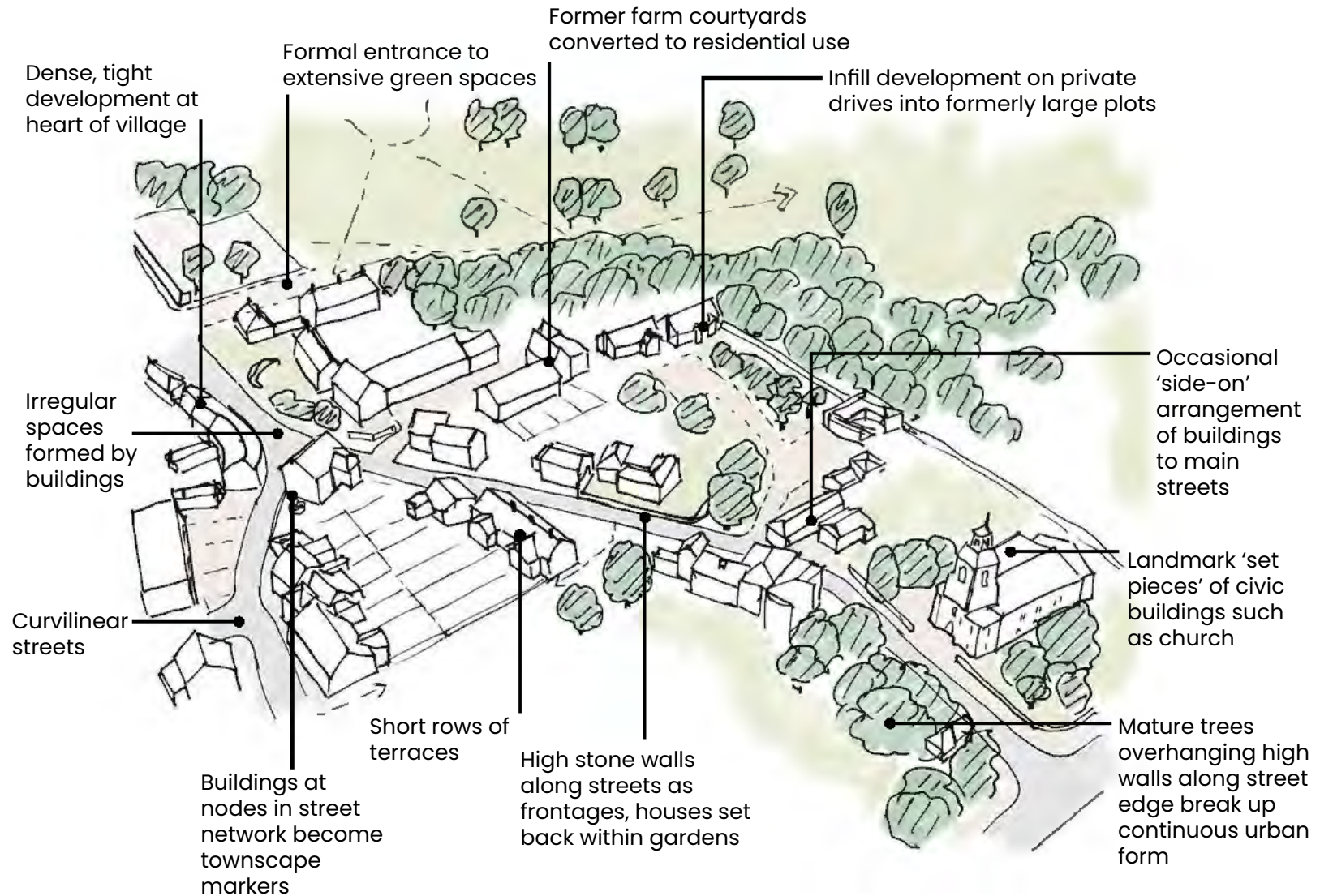

Typical defining features found at the heart of many Spelthorne villages



Find out more background information about the borough in Appendix A 'Understanding Spelthorne Today'.



Area Type Design Requirements

- » Spelthorne's Area Types
- » **4.1 High Streets**
- » **4.2 Town Centre Neighbourhoods**
- » **4.3 Inner Suburban**
- » **4.4 Suburban**

Spelthorne's Area Types

Spelthorne has a number of different Area Types, which are distinctive from each other in urban design characteristics and their future patterns of development.

Different Area Types have different Design Requirements for future development that are appropriate to the area. Find the Area Type your proposal is in on the Area Types Plan to the right to see which requirements apply.

Designated 'Areas of Change' have more detailed coding requirements in addition to their Area Type Design Requirements. These are found in Chapter 5.

Most proposals in Spelthorne will be covered by the Code. **Other Area Types, and some development types, do not have detailed coding.** These design proposals should be in accordance with:

- Requirements for [Design Process](#) (Chapter 2)
- Design Code Vision and principles for the borough (Chapter 1)
- Design Code Vision and principles for the place (Chapter 3)
- Policy requirements as set out in the [Local Plan](#) and other valid policy or guidance

CODED AREA TYPES



High Streets



Town Centre N'hoods



Inner Suburban



Suburban

AREA TYPES NOT CODED



Village





Employment



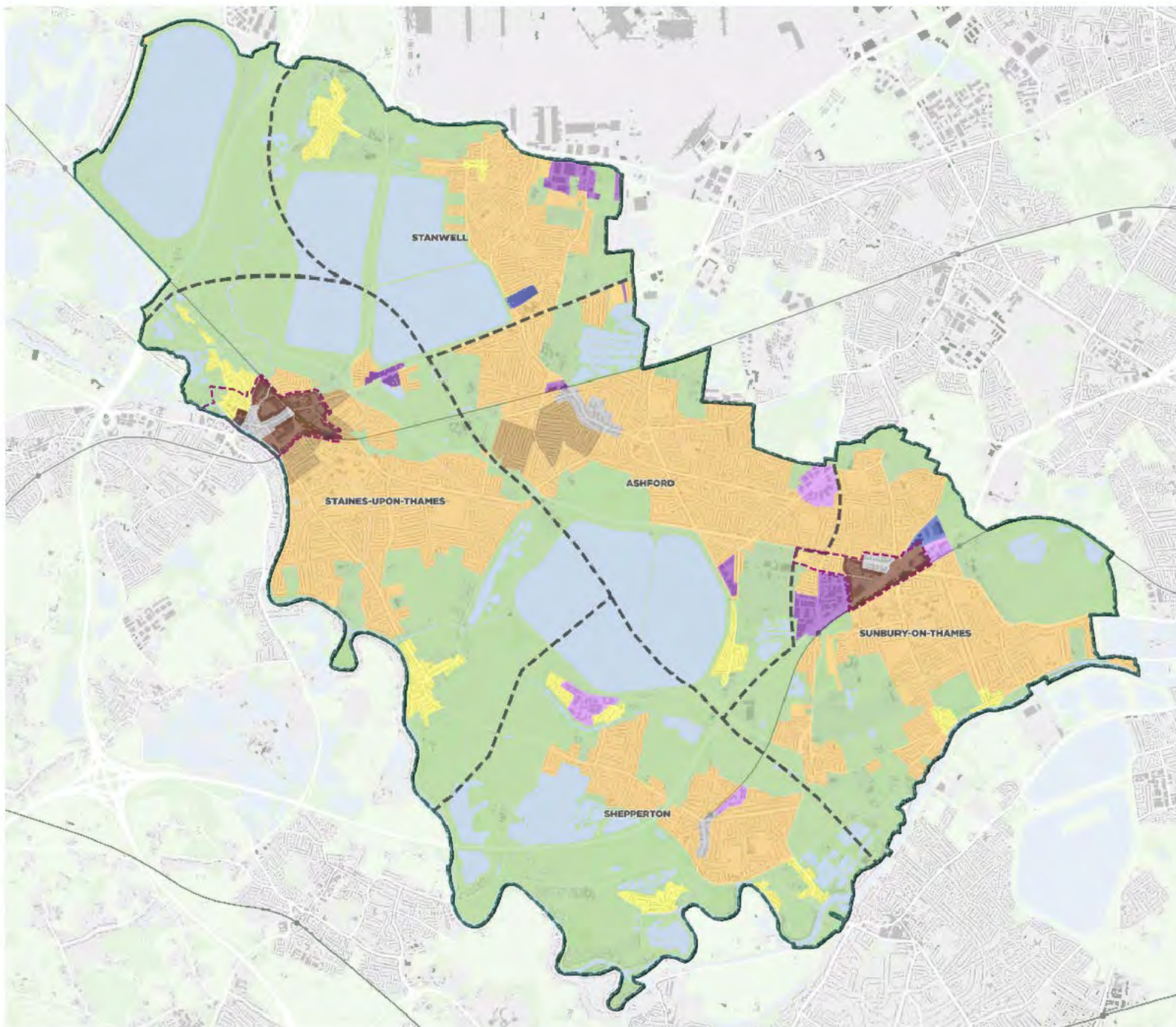



Retail Park







-  Places
See Chapter 3
-  Areas of Change
See Chapter 5

CODED AREA TYPES

-  High Streets
-  Town Centre Neighbourhoods
-  Inner Suburban
-  Suburban

AREA TYPES NOT CODED

-  Green Belt
-  Village
-  Business Park
-  Light Industrial
-  Retail Park

 Waterbodies

4.1 High Streets

OVERVIEW

High Streets are the vibrant heart of Spelthorne, and are both functional places and a core part of the borough's place identity.

There are four identified High Streets within Spelthorne. They are distinct in character from each other but have a number of common features.

- Staines-upon-Thames
- Ashford
- Sunbury Cross
- Shepperton

Staines-upon-Thames has a thriving High Street which is pedestrianised along its core length. Others remain busy streets for vehicles as well as people.

Staines and Ashford are the most historic High Streets, well-developed by the end of the 19th Century. Shepperton and Sunbury Cross develop further in the Inter-War and post-War period.

CODED DEVELOPMENT TYPES

All development along High Streets in Spelthorne is anticipated to be of the form of mixed use buildings, with retail or commercial ground floors and residential dwellings or office space on floors above.

AREAS OF CHANGE

Staines-upon-Thames and Sunbury Cross High Streets are both parts of Areas of Change. As well as the requirements set out in this section, they are subject to further spatial coding requirements set out in Chapter 5.

Development in Ashford and Shepperton High Street is anticipated to be incremental and governed by the design requirements set out in this section.

LOCATIONS

Locations of High Streets in Spelthorne are shown on the following page.

DESIGN AIMS

Development in High Streets **will**:

- Be incremental in form, being guided by existing dimensions of height, width, set back and building line
- Include retail and commercial uses on the ground floor to ensure the continued vibrancy and importance of High Streets as key places in Spelthorne
- Support a transformation in the public realm to prioritise active travel
- Be attractively and thoughtfully detailed and articulated with appropriate materials to integrate visually with the context and surrounding place



Spelthorne's High Streets are distinctive and important to the community. Development must 'fit in'.



4.1.1 BUILDING HEIGHTS

Maximum heights of new development **must** comply with the requirements set out in the diagram to the right, and not exceed the maximum heights specified below.

- Staines-upon-Thames: 6 storeys (approx 18m). Further detail in Chapter 5, Areas of Change.
- Ashford: 5 storeys (approx 15m)
- Shepperton: 5 storeys (approx 15m)
- Sunbury Cross: 5 storeys (north side, approx 15m), 8 storeys (south side, approx 24m). Further detail in Chapter 5, Areas of Change.

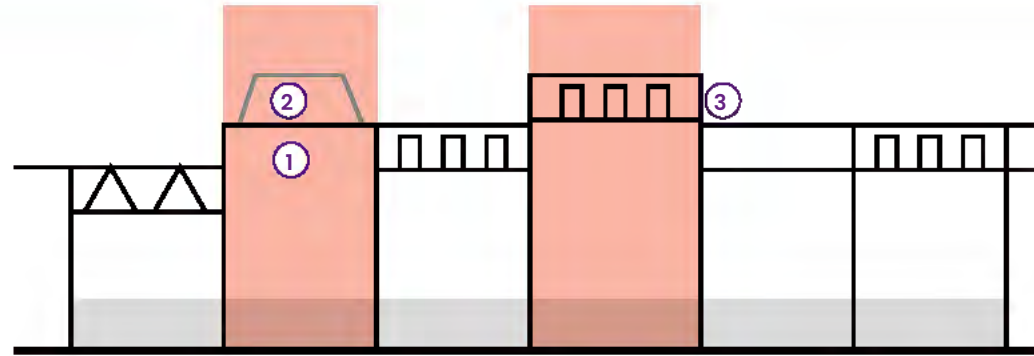

Development between different heights may:

1. Have one storey higher than the lower adjacent building, up to the maximum heights specified.
2. Have one storey higher than the taller adjacent building, provided it is set back from the building line and the flank facing the lower adjacent building, and does not exceed the maximum heights specified.

Development between similar heights may:

3. Be one storey higher than adjacent buildings, up to the maximum heights specified.

4.1.2 BUILDING LINES

Spelthorne's High Streets have a consistent building line, with most buildings built up to the front of the plot and joining adjacent buildings.

New development **must**:

- Match the surrounding building line and build to the front of the plot
- Ensure where possible at least a 2m footway width in front of the building
- Join adjacent buildings with a party wall
- Where there is a change in building line from one side of a plot to another address the change as shown in the diagram to the right

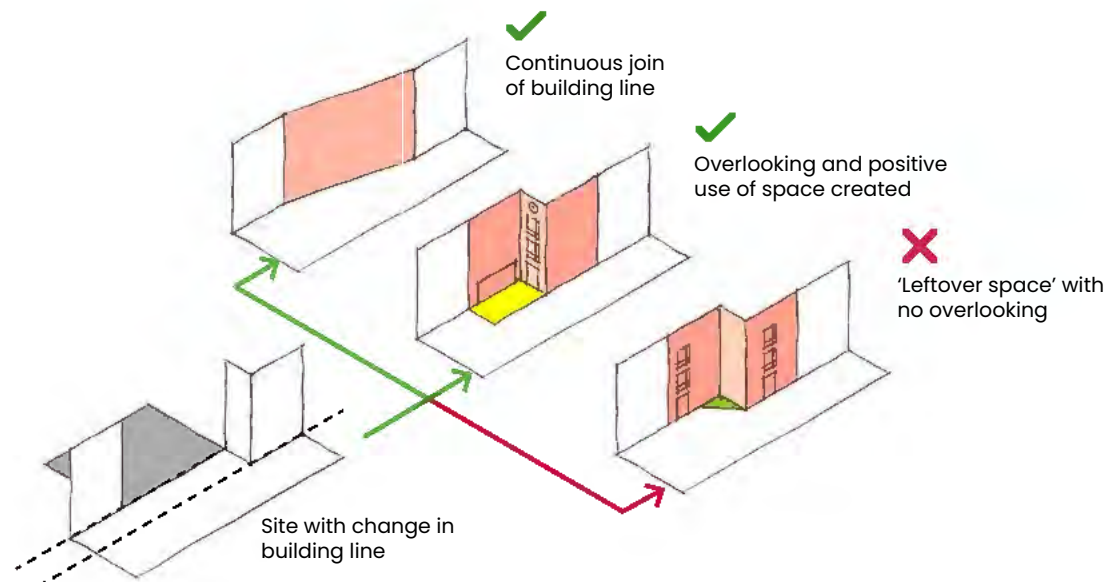

4.1.3 BUILDING GRAIN

The plot structure of Spelthorne's High Streets typically leads to relatively narrow buildings, referred to as a fine urban grain. It is also common to see buildings that are wider than this typical grain subdividing the frontage so as to match.

Buildings **must** visually match the prevailing building width of:

- Staines-upon-Thames: 6-10m
- Ashford: 5-10m
- Shepperton: 6-20m, with most buildings wider than 10m subdivided visually
- Sunbury Cross: 6-10m, with most buildings wider than 10m subdivided visually



Ashford - plots and building figure ground showing fine grain of built form



Subdividing the frontage of a single building to match the prevailing grain and rhythm of a High Street (Lower Marsh, Waterloo)

4.1.4 VERTICAL MIX OF USES

High Streets are defined by their varied ground floor uses. Buildings on High Streets are expected to be mixed-use vertically.

Buildings **must**:

- Have a commercial ground floor suitable for flexible retail use, with a floor-to-floor storey height of at least 4.3m to allow for future changes in use
- Have either office or residential dwellings (apartments) on upper floors, with storey heights typically lower, of around 3m
- Have separate entrances for upper floor offices or dwellings, from the High Street

Buildings **should**:

- Locate servicing for retail units to the rear of the building. If servicing is necessary from the street this should be outside of retail hours.

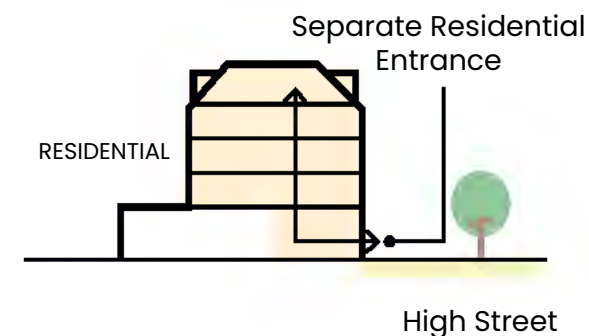
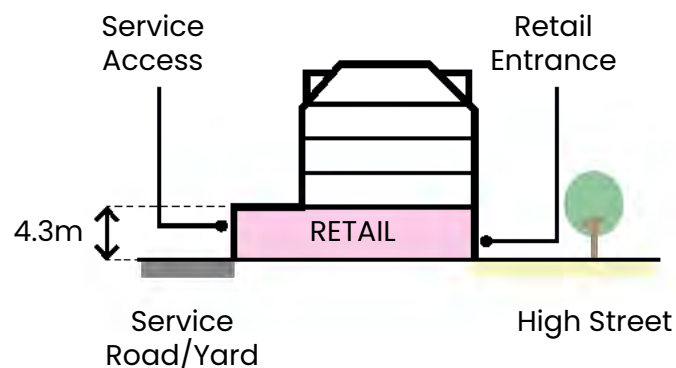

4.1.5 HIGH STREET PUBLIC REALM

Ashford, Shepperton and Sunbury Cross have High Streets with through vehicle traffic, service lanes and occasional streets. They are typically between 25-35m in width.

With phased changes in the design of the public realm, these streets can provide more space for pedestrians, cyclists and active uses of the public realm, while still accommodating car parking and vehicle movement successfully.

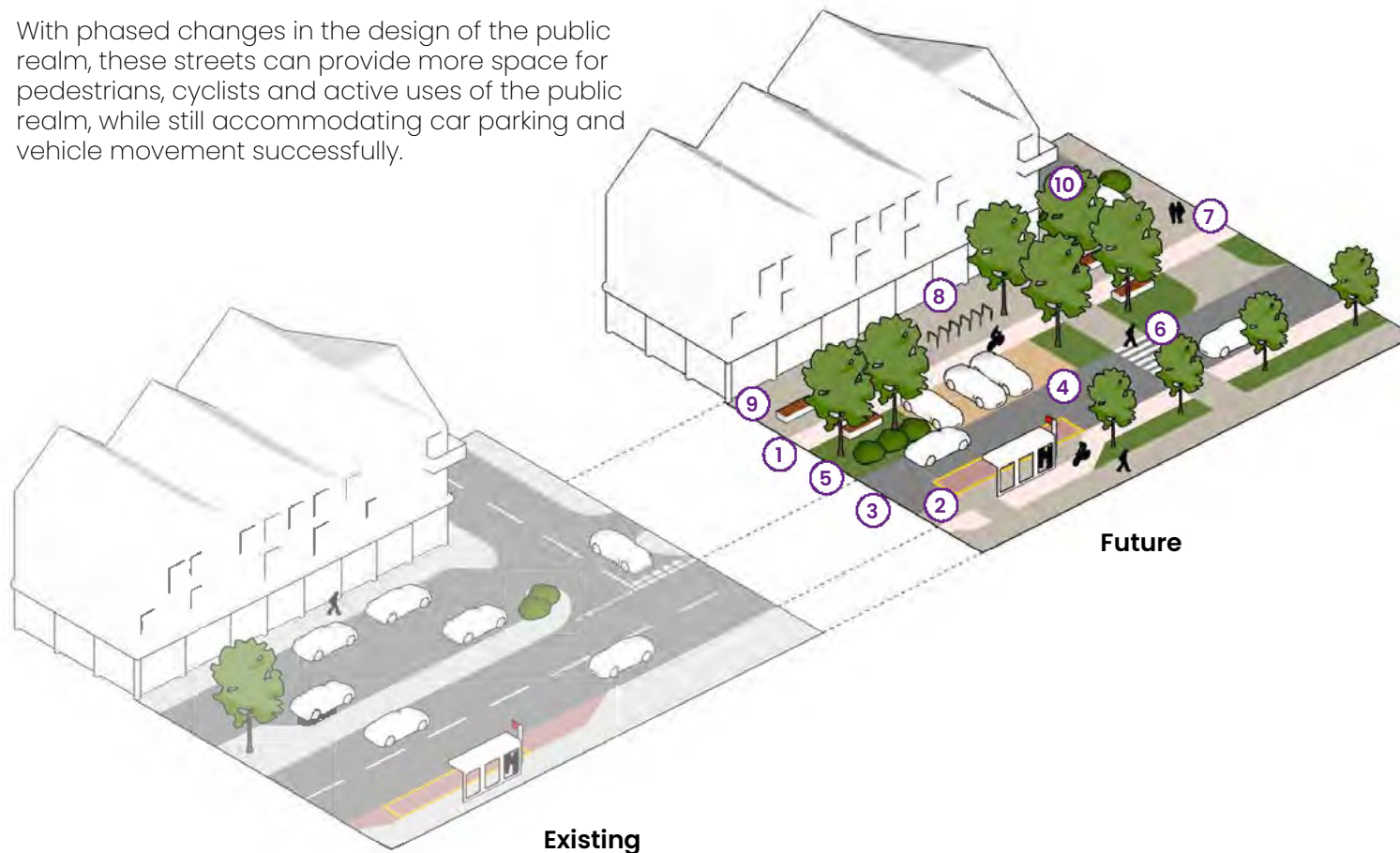

Public realm changes to High Streets **must** follow the principles of Surrey's Healthy Streets Design Code.

Spelthorne's High Streets **should**:

1. Include dedicated cycling provision to LTN 1/20 standards
2. Provide dedicated passenger waiting space at bus stops that does not block footways
3. Limit vehicle carriageway widths to the minimum required
4. Provide on-street parking as bay, parallel or angled arrangements off the main carriageway, with differentiated surface treatments and a maximum of six parking spaces in a run
5. Integrate parking bays into a flexible planting and street tree strip, which can also accommodate seating, lighting, cycle parking and wayfinding
6. Provide frequent pedestrian crossings at key desire lines
7. Provide continuous footways at junctions with side roads
8. Include frequent cycle parking at gateways and junctions along the street
9. Include seating at least every 50m
10. Use streets and landscape design to mark key locations in the street



The quality of the public realm, and poor facilities for walking and cycling, detracts from High Streets today.

4.1.6 SHOP FRONTS

The design of shop fronts and building façades will make a strong contribution to the character of the High Street.

Shop fronts **must**:

- Adopt a unified approach to shop front design where buildings are architecturally in the same group within a terrace (e.g. the same building) (diagram centre right)
- Adopt an individual approach to shop front design for buildings which are individual (diagram far right)
- Reflect the width of historic plot pattern in their design



Unified approach to shop frontages on the same terrace of buildings



Individual approach to shop frontages on individual buildings

4.1.7 FACADES

Above shop fronts, High Street façades **must**:

- Have a roof visible from the street, e.g. a gable end, pitched roof or mansard roof. Flat roofs will not be accepted.
- Have a base of a single storey, used as a shop front
- Be visually proportioned so that floor and window heights decrease vertically
- Match the rhythm of windows along the street
- Use materials with texture or decorative detail visible at close distances, such as brick, to create visual interest

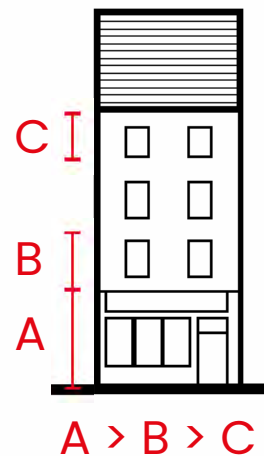

Proportions of base, middle and top floors in relation to each other



Matching the rhythm of windows along a High Street



Example of decorative detail separating shop front from upper floors (Wellington House, MATT Architecture)



Rich, detailed building façades which have parameters in common with adjacent buildings are popular.

4.2 Town Centre Neighbourhoods

OVERVIEW

Staines-upon-Thames and Sunbury Cross are town centres where a significant increase in homes is anticipated close to or within the town centre. This development will form new mixed-use neighbourhoods, where facilities and amenities are within walking distance of homes, and other destinations can be accessed by frequent public transport.

Town centre neighbourhoods will be of higher residential density than is typically seen in Spelthorne. They will have residential dwellings and supporting commercial and community facilities, as well as retail space that integrates with the rest of the town centre.

Some parts of town centre neighbourhoods have already been built, for example along London Road in Staines-upon-Thames. As neighbourhoods develop or are regenerated, it will be important to integrate these neighbourhoods into the surrounding town centre, with new streets and open spaces that can bring the existing and new community together.

CODED DEVELOPMENT TYPES

All development in Town Centre Neighbourhoods is anticipated to be in the form of medium to high density residential-led mixed use buildings, with some retail or commercial ground floors. This will include a range of densities and development types from townhouses to towers.

AREAS OF CHANGE

All Town Centre Neighbourhoods in Staines-upon-Thames and Sunbury Cross are designated as parts of Areas of Change. As well as the requirements set out in this section, they are subject to further spatial coding requirements set out in Chapter 5.

LOCATIONS

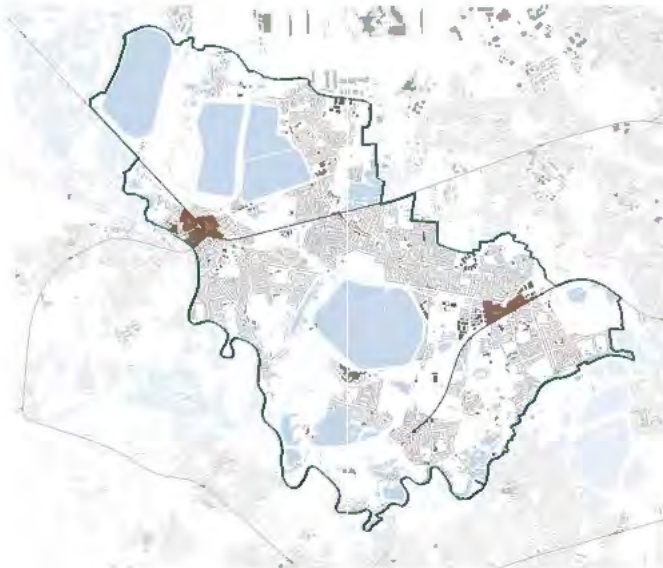

DESIGN AIMS

Due to the importance of design quality in new and emerging Town Centre Neighbourhoods, Design Aims and corresponding Requirements are set out across six themes:

- The Street & Ground Floor
- Scale & Massing
- Open Spaces
- Homes & Practicalities
- Detail & Richness
- Climate Change & Sustainability



New neighbourhoods must be a part of the existing place, helping new residents be part of the community.



High quality open spaces, affordable, attractive new homes, and appropriate development scale are priorities.



Variety of types of home - duplexes, maisonettes, apartments and others

Range of private and shared amenity spaces

Space for nature as well as people

Local facilities and shops

Getting about by walking and cycling is the most attractive option

Safe, attractive and green public open spaces

4.2.1 The Street & Ground Floor

The street and public spaces are how most people will experience Spelthorne's town centre neighbourhoods, and are of vital importance to the identity of places, and successful integration with their surrounding town centres and neighbourhoods.



Residential active frontage



Spill-out space for cafe seating on walking route

DESIGN AIMS

The Street & Ground Floor of Town Centre neighbourhoods **will**:

- Maximise active frontages at ground level, whether they be commercial or residential
- Connect the indoors with the outdoors, with appropriate ground floor uses aligned to the adjoining public realm or outdoor space
- Use the built form and design of the public realm to ensure all space has a positive purpose
- Provide a network of streets that prioritise people and active uses over cars, designed on 'superblock' principles
- Include street trees and planting in the public realm

4.2.1.1 ACTIVE FRONTAGES

The ground floor connects the street with the activity within the building, and creates safe and secure environments through passive surveillance. Different frontages and design requirements are set out on the next page.

Development **must**:

- Locate frontages with a higher level of activity on busier streets
- Locate **active frontages** to provide passive surveillance of surrounding areas which lack overlooking from other buildings
- Not have more than 10m length of continuous inactive or low activity frontage
- Have ground-floor entrances to homes, retail or commercial space at least once every 10m

4.2.1.2 SPILL-OUT SPACE

Active ground floor uses such as retail, cafes, restaurants, community spaces and leisure uses can further animate the street by providing 'spill-out' public realm space for tables, activities and events.

Development **must**:

- Provide 'spill-out' space of at least 2m width on high activity retail and commercial frontages where there is direct sunlight and shelter from winds
- Demarcate spill-out space, e.g. by a change in surface materials

Development **should**:

- Align internal uses (e.g. cafes) with external spaces (e.g. squares and open spaces)
- Provide shelter of spill-out space through temporary or retractable awnings



A feeling of safety and security in the public realm at all hours is a key community priority.

(4.2.1.1/4.2.1.2) Types Of Frontage and Spill-Out Space

This diagram sets out the different types of frontage in town centre neighbourhoods. Proposed frontages **must** achieve these design requirements.

Retail Frontages & Commercial Entrances

A source of activity and vibrancy on main streets. Allow indoor uses to 'spill out' onto the street with a demarcated space extending the public realm.

High Activity

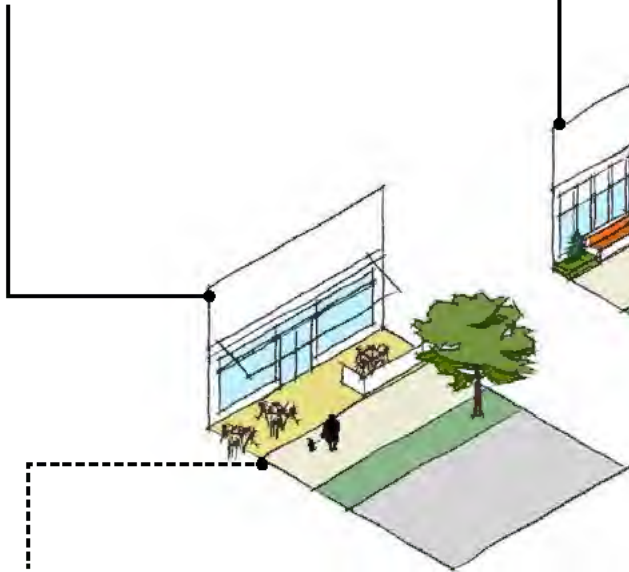

Flexible 'spill-out space' of 2m+ width with differentiated materials

Retractable awnings may be used

Commercial

Provides overlooking from ground floor offices and other commercial uses.

Medium Activity

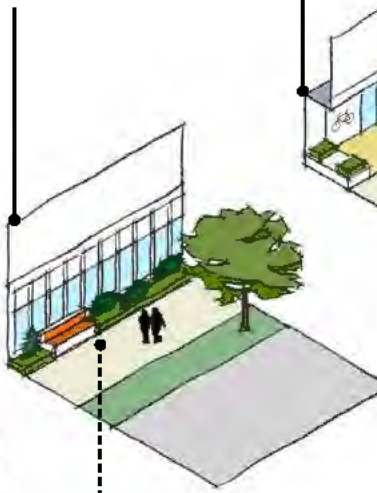

Glazing to provide visibility to public realm

Seating and planting at interface with street

Apartment Entrances

Provide a safe, comfortable and welcoming threshold that feels like home.

Medium Activity

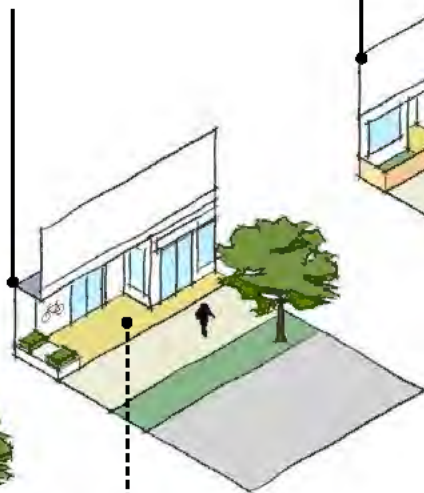

Covered threshold of 1.5m+ depth

Adjacent to retail entrances where possible

Cycle storage at entrance

Planting and seating to enclose threshold space

Homes

Promote interaction between neighbours and a welcoming, safe threshold space.

Medium Activity

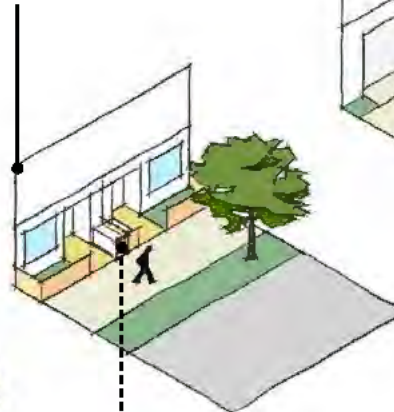

Front gardens of 1m+

Front doors have covered threshold

Bin storage space adjacent to front door

Service / Parking Access

Minimise the visual impact and lack of activity around these frontages

Inactive / Low Activity

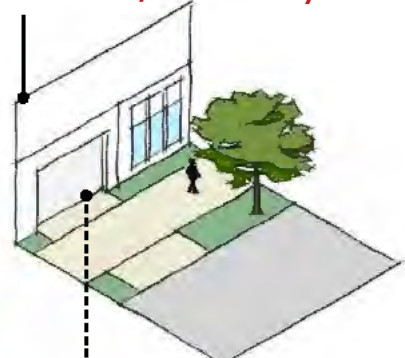

Minimise width of this frontage type, maximum 10m continuous width

Entrances flush with frontage

Continuous footway past entrance

4.2.1.3 STREET NETWORKS AND DESIGN

New town centre neighbourhoods **must** be designed on the principle of prioritising the movement of people and active travel within and through the neighbourhood, with vehicle traffic directed onto suitable streets away from people-focused hearts of neighbourhoods.

- Streets within town centre neighbourhoods should be designed as Pedestrian Priority Streets, to prioritise active travel, and the use of the street for play, relaxation, socialising and active uses such as cafes or similar.
- Streets at the edge of town centre neighbourhoods, which are today designed as large traffic-dominated roads, should be re-imagined as Multi-Modal Streets.

Design requirements for these two key street types are set out on the following page. These follow the principles of Surrey's Healthy Streets Design Code.

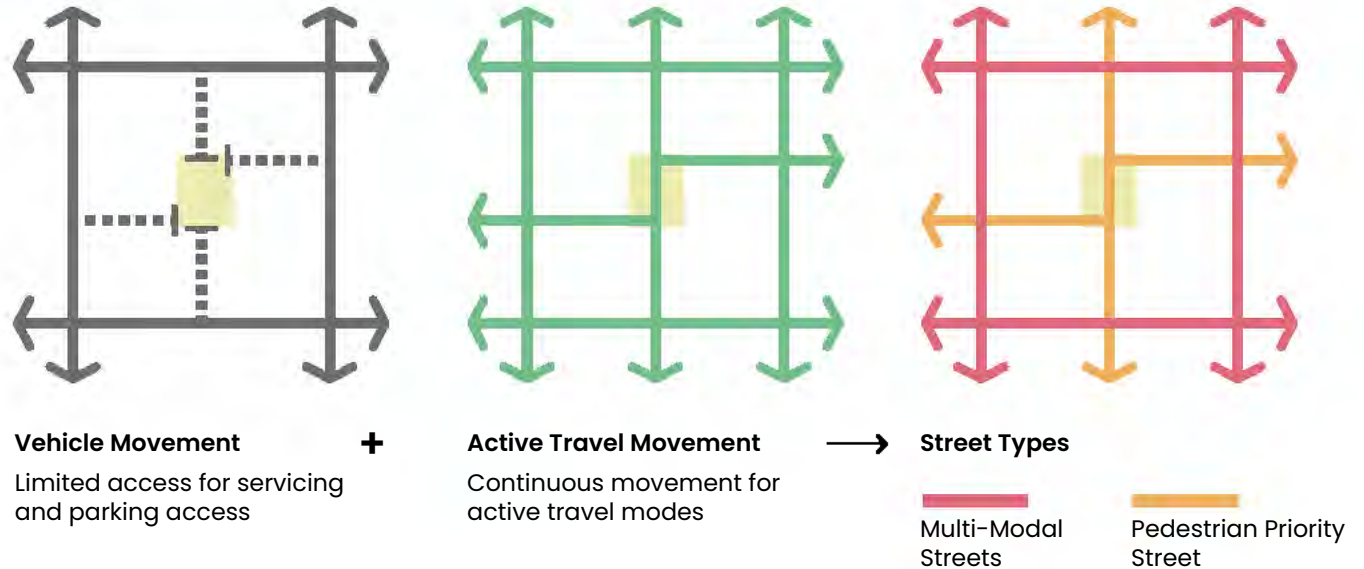

Neighbourhood street network design approach

4.2.1.4 STREET TREES AND PLANTING

Street trees provide multiple benefits, including shade, shelter, improvements to air quality, water handling, urban habitats and aesthetic contribution to the character of streets. Other planting can make contributions to some of these aspects and is encouraged.

Where development creates new public realm or streets, they **must** be tree-lined and planting should be integrated throughout the public realm.

Further requirements for landscape and street tree selection are found under TC-05.



Street trees and planting in a residential street



Trees providing shade in public open space

(4.2.1.3) Types Of Street

This diagram sets out design requirements for the different street types within town centre neighbourhoods.

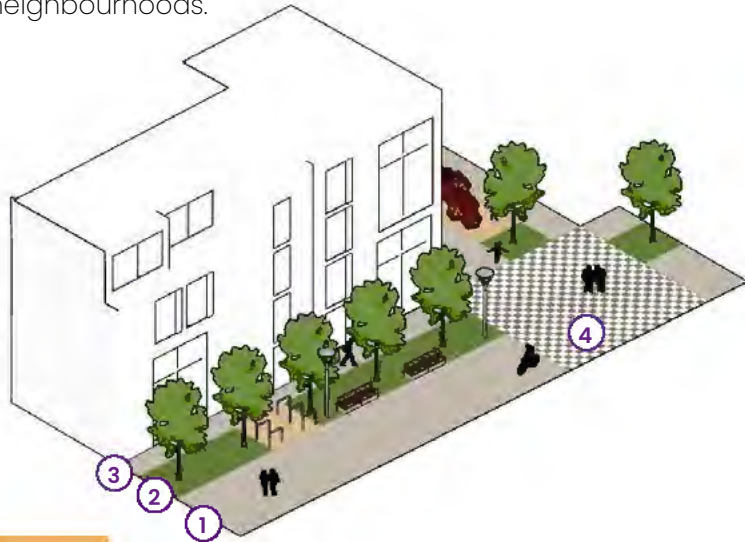

Pedestrian Priority Street

4.2.1.3a Pedestrian Priority Streets will vary in character to reflect the surrounding built form and intended vision of the town centre neighbourhood. At a minimum they **must**:

1. Have a shared surface area of at least 5m wide to provide occasional service access or limited access to car parking
2. Have a planting or landscape strip e.g. of at least 3m wide to be able to accommodate street trees, cycle parking, seating, lighting, planted areas, informal play features and surface water management
3. Have a minimum 2m wide footway between the landscape strip and built form front boundary
4. Use differentiated surface material at junctions between pedestrian priority streets

Multi-Modal Streets

Few (if any) schemes will create new multi-modal streets in town centre neighbourhoods. Most new town centre neighbourhoods will redevelop existing sites and be adjacent to existing major streets. These streets can be redesigned to reduce the dominance of vehicle traffic and provide more space for people and other modes, as shown below.

4.2.1.3b Multi-Modal Streets **must**:

1. Be fronted by built form with active ground floor frontages
2. Include dedicated cycling space to LTN 1/20 standards
3. Have regular pedestrian crossings that connect with desire lines
4. Be tree-lined and include planting areas, retaining existing street trees
5. Include a flexible strip of planting, seating, cycle parking to help delineate movement modes from each other

Reduce the space dedicated to vehicle traffic

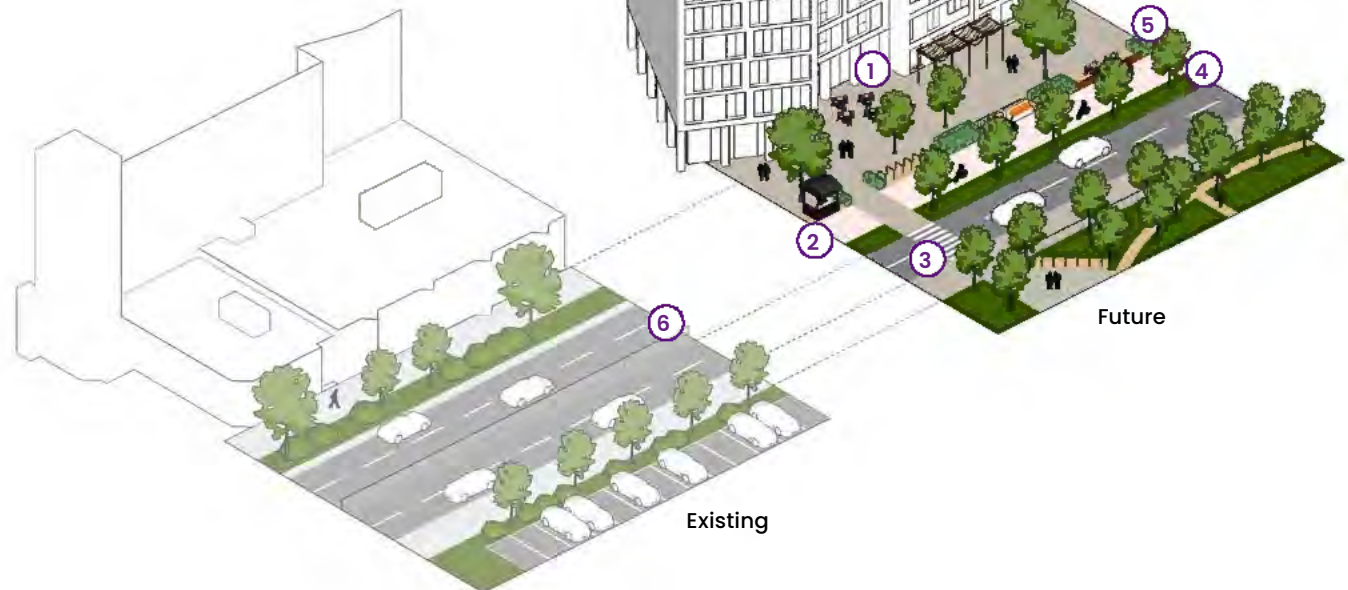

4.2.2 Scale and Massing

Scale and **massing** must be contextually-sensitive and successfully manage transitions to surrounding areas whilst ensuring an efficient use of land. High density does not need to mean high-rise, and well-designed medium-rise schemes are strongly encouraged in all of Spelthorne's town centre neighbourhoods.

DESIGN AIMS

The scale and massing of Town Centre Neighbourhoods **will**:

- Consider and minimise the impact on how they will be perceived from the street and areas of local distinctiveness and importance
- Make a positive choice of massing typology that balances integrating with the existing context with the need for efficient use of land in accessible, sustainable locations
- Ensure massing, especially of tall buildings:
 - has a varied elevation over their height
 - does not overwhelm the scale of the surrounding street
 - breaks up elevations through use of materials and facade design
 - keeps a street level microclimate, daylight levels and wind effects that are comfortable

4.2.2.1 NEIGHBOURHOOD MASSING APPROACH

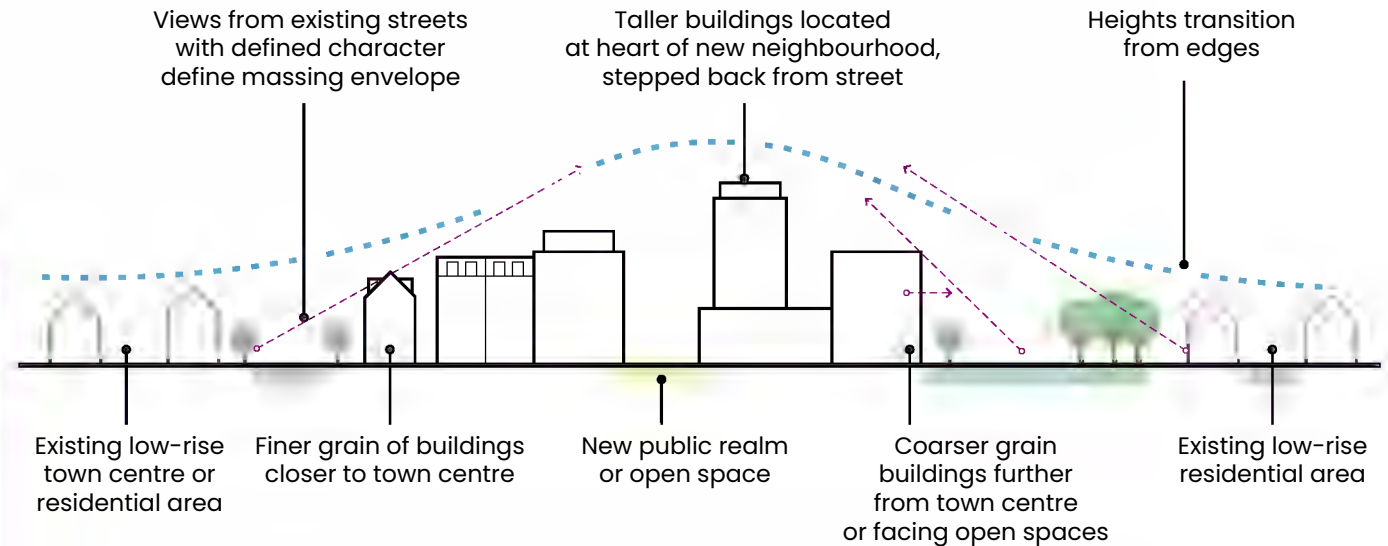

An overall approach to **massing** of new town centre neighbourhoods is set out in the diagram above. Scale and **massing** includes both the vertical (height) and horizontal (grain) measurements of buildings.

New neighbourhoods may be delivered through a number of different sites. The overall principles will apply across sites, and are defined in detail in Chapter 5, 'Areas of Change'.

New town centre neighbourhoods **must**:

- Transition gradually in height and urban grain from surrounding areas
- Locate taller buildings away from existing low-rise areas



The effect of change on the skyline and character of Staines-upon-Thames is important to the community.



Existing tall buildings in Sunbury Cross create a poor environment which could benefit from mid-rise development.

DENSITY IN SPELTHORNE’S TOWN CENTRE NEIGHBOURHOODS

Spelthorne’s town centre neighbourhoods will vary in prevailing density, measured both in dwellings per hectare and in floor area ratio. Anticipated categories of development, their typical density characteristics, and the places in which they are considered appropriate are set out below.

As set out in the ‘Design Process’ chapter, **the appropriate density for a site will be design-led**, responding to constraints, the existing context, and the requirements set out in this Design Code for Areas of Change.

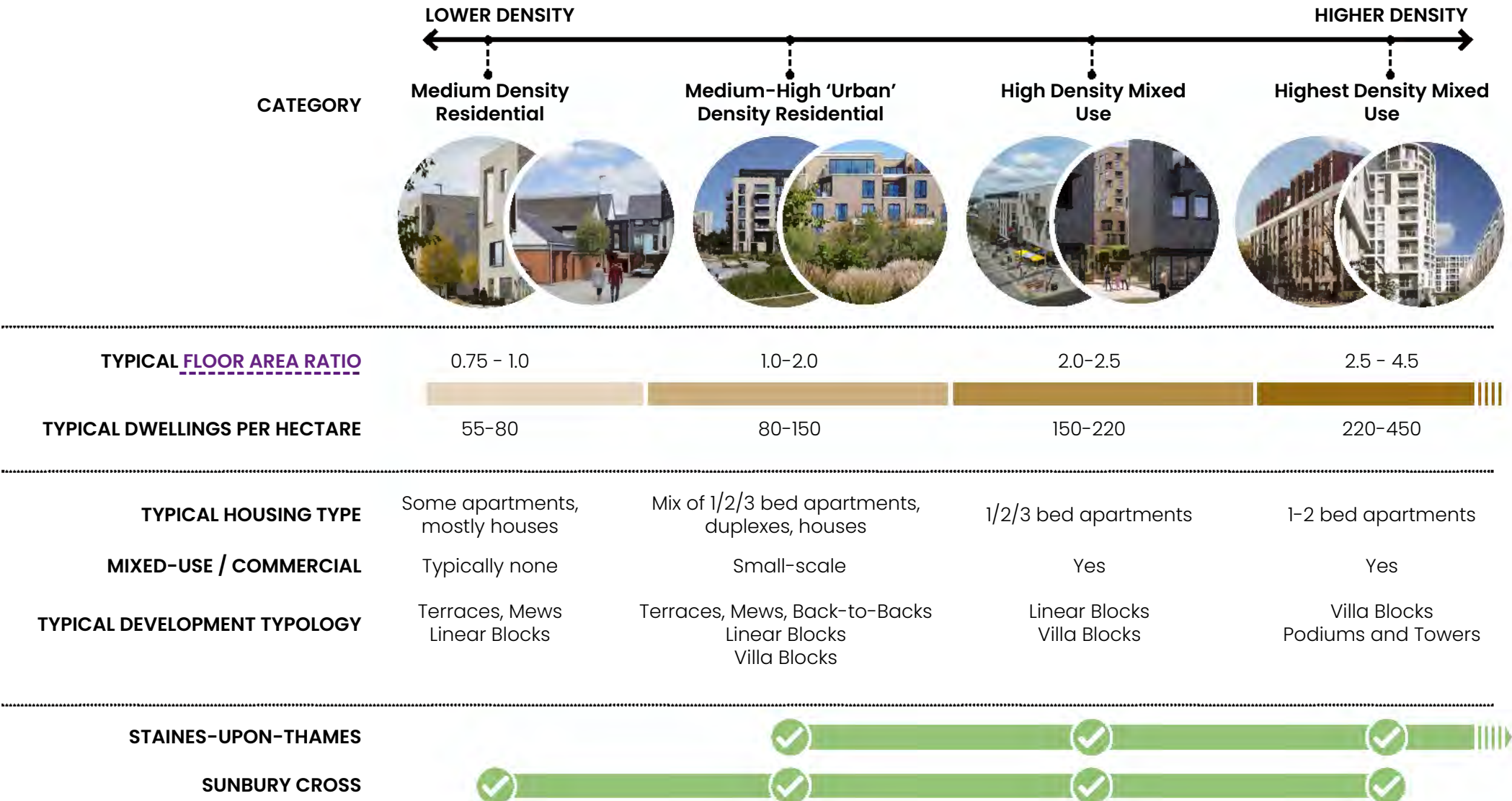

4.2.2.2a Low-Rise: Terraces, Back-To-Backs And Mews Houses

Terraces, back-to-backs and mews houses can provide relatively high densities of houses within low-rise streets that can blend well with the existing character of Spelthorne's town centres and streets. They can help bridge the transition between lower and higher-density development. Care should be taken to ensure sufficient green space, parking and privacy for residents are maintained.

Dimensions this type **must** observe:

- Height up to 3 storeys (approx 15m)
- Typically 2-4 bed homes
- Building depth 7-10m
- Frontage width 5-8m

Most Suitable Locations where this type **should** be located:

- Edges of higher density sites as part of transition to surroundings
- Quieter side streets
- Near areas with strong existing character to be preserved
- Mews streets inserted into centre of perimeter blocks in new neighbourhoods

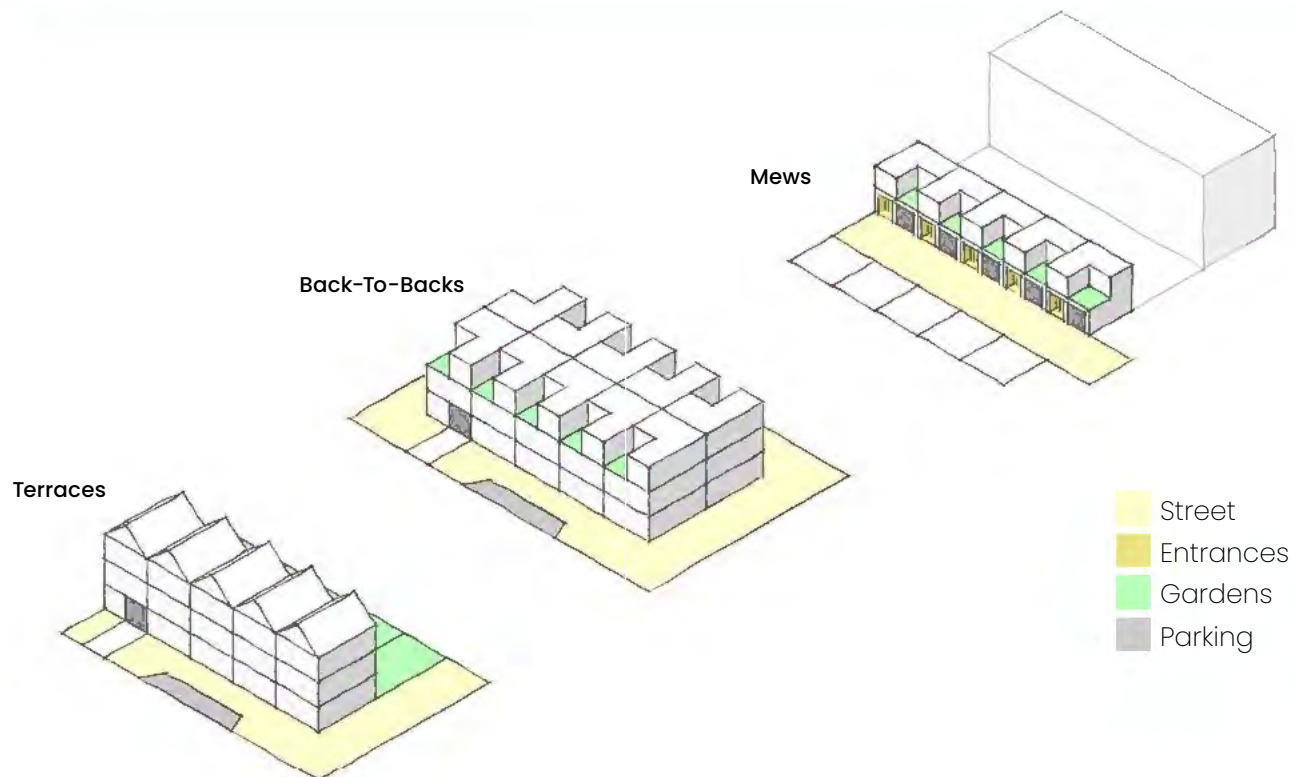

DESIGN REQUIREMENTS

Terraces, back-to-backs and mews **must** include:

Street and Public Realm

- Typically no commercial ground-floor frontages or uses
- Shared space or pedestrian-priority streets

Scale and Massing

- Limited variations in height
- Mix of contemporary and traditional pitched roof types

Open Spaces

- Private gardens and terraces, including roof terraces
- Any shared open spaces delivered as part of public realm

Homes and Practicalities

- Front doors on street for all homes
- Car parking on-street, in off-plot parking areas or integral to homes
- Single-aspect types not located facing primarily north or south, to prevent overheating or lack of access to daylight



Providing family homes within town centre neighbourhoods is strongly supported.

4.2.2.2b Medium-Rise: Linear Blocks

At medium densities and heights, linear blocks can accommodate a range of housing types within a mid-rise town centre neighbourhood. These can often fit into relatively narrow blocks and create a legible urban environment with a mix of quieter and busier frontages and streets.

Dimensions this type **must** observe:

- Height typically 4-6 storeys (approx 18m)
- Deck access heights limited to 5 storeys (approx 15m).
- Mix of duplexes, maisonettes and apartments
- Building depth 8-12m to ensure dual-aspect dwellings throughout
- Frontage widths flexible, typically articulated at 6-10m intervals to align with dwellings
- For point access, a maximum of two dwellings served on each floor per core
- For deck access, a maximum of six dwellings served on each floor per core

Most Suitable Locations where this type **should** be located:

- Edges of higher density sites as part of transition to surroundings
- Larger infill sites on the peripheries of town centres
- Near areas with strong existing character to be preserved
- Sites that have a lower proportion of commercial uses

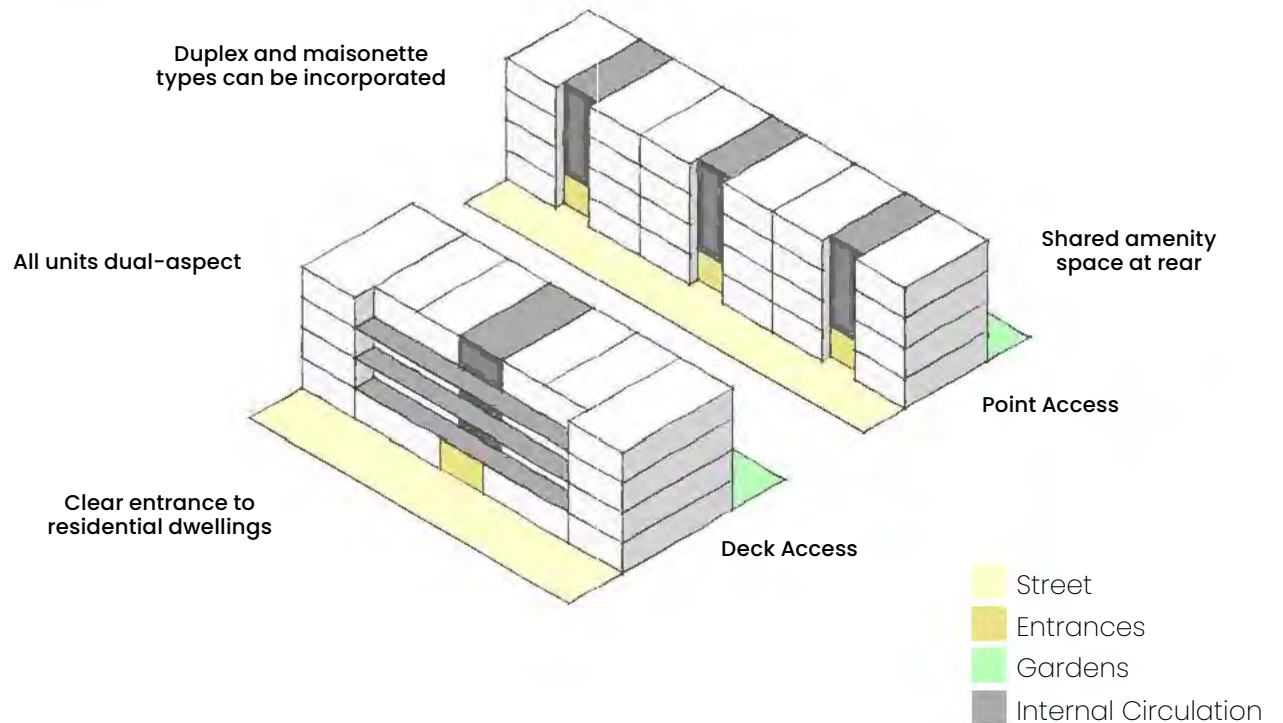

DESIGN REQUIREMENTS

Linear blocks **must** include:

Street and Public Realm

- Residential active frontages
- Any commercial ground-floor active frontages or uses located facing onto busier streets

Scale and Massing

- Mix of roof types to differentiate buildings
- A minimum of 2 hours direct sunlight on 21st December to all units, ensured by the spacing of buildings

Open Spaces

- Private gardens and terraces, including roof terraces for maisonettes and duplexes
- Shared gardens for duplexes and apartments

Homes and Practicalities

- Both deck access or internal (point/walk-up) access possible.
- Front doors on street for maisonettes ground floor units
- Car parking on-street or integral to homes for maisonettes, shared off-plot provision required for other forms
- Accessible, level access to all homes

4.2.2.2c Medium-Rise: Villa Blocks

This typology can provide a flexible mix of higher density apartment buildings and ground-floor commercial uses set within a network of open space or as part of other typologies. They are typically double-fronted at ground level enabling them to be flexibly used, but care needs to be taken to ensure frontages are active and servicing is located in the right places.

Dimensions this type **must** observe:

- Height typically 5-10 storeys (approx 15-30m)
- Floors above 8 storeys (approx 24m) should be set back
- Mix of 1, 2 and 3 bed apartments
- Building depth 14-20m
- Building width 20-30m
- Subdivision of frontage to create finer visual grain on larger buildings
- No more than eight dwellings on each floor served by a single core

Most Suitable Locations where this type **should** be located:

- On key corners and busier streets
- Adjacent to green open spaces, ensuring views for residents
- As the main component in many medium-high density developments away from sensitive edges

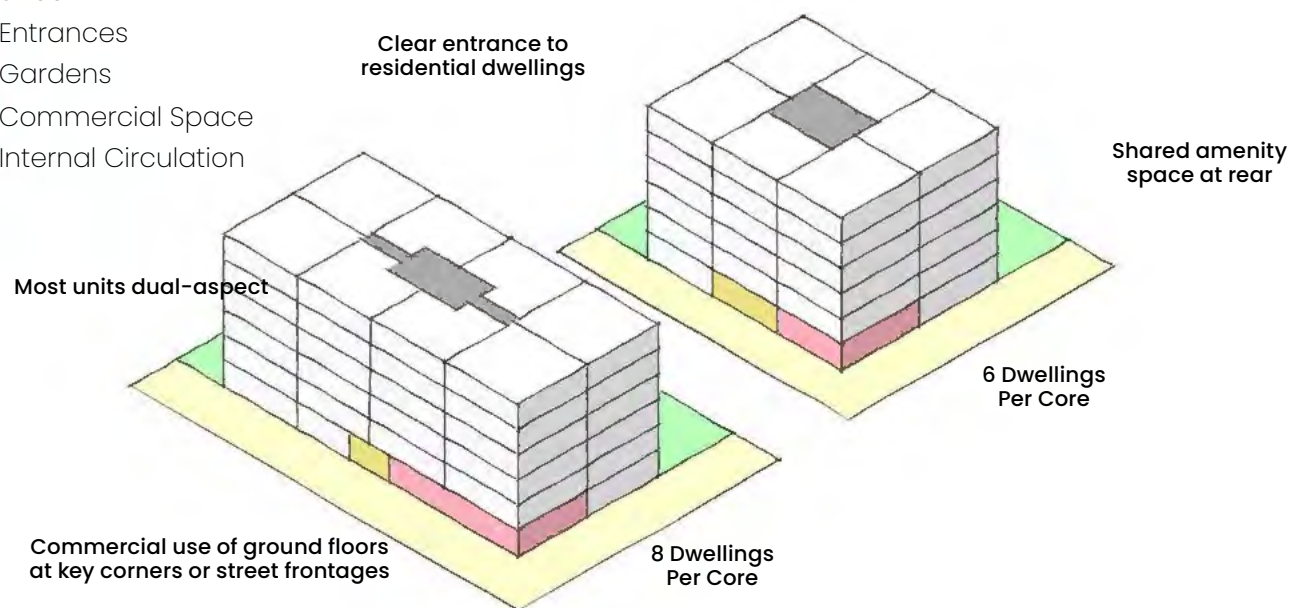
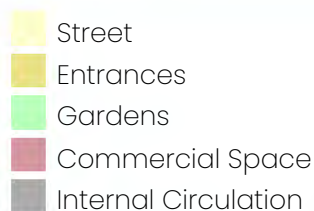

DESIGN REQUIREMENTS

Villa blocks **must** include:

Street and Public Realm

- Commercial ground-floor **active frontages** or uses at key nodes

Scale and Massing

- Within larger sites with multiple buildings, lower heights used on southern sides of sites to ensure daylight access to open spaces
- Incorporate plant within the roof design

Open Spaces

- Private balconies and terraces
- Shared amenity open spaces between buildings need to be on a podium or have some change in levels from the public realm to provide separation from the street

Homes and Practicalities

- Shared entrances for apartments can be provided on both sides of building
- At least half of units dual-aspect
- Central core providing access to all upper-floor units
- Shared refuse and cycle storage at ground level
- Individual entrances to units located on the ground floor
- Private gardens for units fronting onto shared amenity spaces
- Car parking either underground or housed off-plot
- Accessible, level access to all homes

4.2.2.2d Medium To High-Rise: Podiums And Towers

Towers with apartments provide the highest-density option for new residential development. They can also be the most impactful on surrounding areas due to their scale, can deliver a large number of high-quality new homes in town centres, and can have impacts on the street due to overshadowing and wind effects. As such they require careful design.

Due to safeguarding restrictions for Heathrow Airport, the maximum height of any development in Spelthorne is 45m (approximately 15 storeys).

Further requirements for tall buildings are set out under 'Tall Building Design Requirements' later in this section (4.2.2.3).

Dimensions this type **must** observe:

- Towers sit on and are set back from a podium or base building
- Heights: towers of between 10-15 storeys (30-45m), lower base/podium up to 6-8 (approx 18-24m) storeys
- 1-2 bed apartments, some 3-bed apartments possible
- Tower width and depth typically 20-30m
- No more than eight dwellings on each floor served by a single core

Most Suitable Locations where this type **should** be located:

- The highest density town centre areas
- As part of town centre neighbourhoods where an appropriate transition has been achieved, in line with the overall approach to **massing** set out earlier in this section

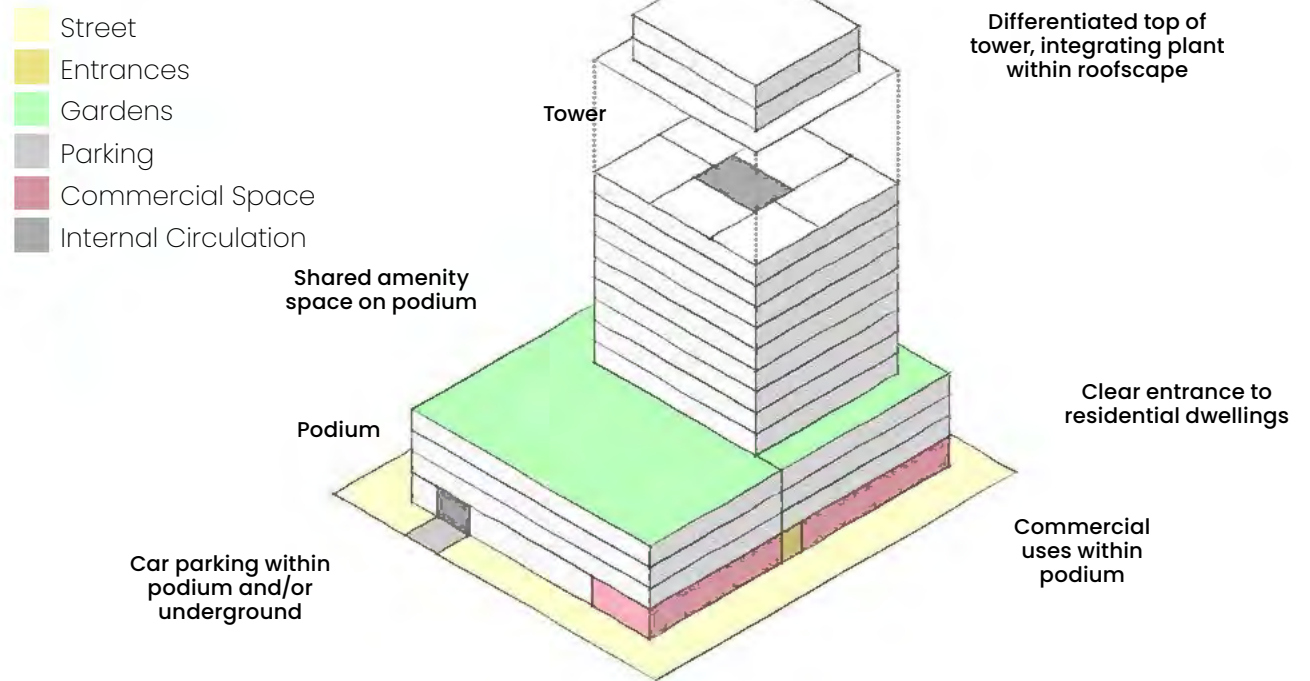

DESIGN REQUIREMENTS

Podiums and towers **must** include:

Street and Public Realm

- Commercial ground-floor uses within podium
- Podium to provide strong edge to street, with no open space without a clear use or ownership (public/private) around the tower base

Scale and Massing

- Towers to comply with the tall building requirements set out on the following pages

Open Spaces

- Private balconies and terraces, including roof terraces
- Balcony types to comply with tall building requirements on following pages
- Shared podium gardens to provide amenity space for residents

Homes and Practicalities

- Shared entrances for apartment blocks located on the street, with a connection through to any shared podium garden
- Car parking underground, within podium, or a combination of both.
- Accessible, level access to all homes

Applied Example 1

Approx 200 dwellings per hectare (dph), Floor Area Ratio 1.85

The site below is 100m x 60m, adjacent to a busy commercial street and surrounded by lower-rise side streets, that transition to existing residential areas. The example maximises the potential of the site by selecting typologies on side streets that provide moderate intensification of built form, and locate the densest typologies along the main street. To increase the variety of provision a mews street is inserted into the centre of the block.

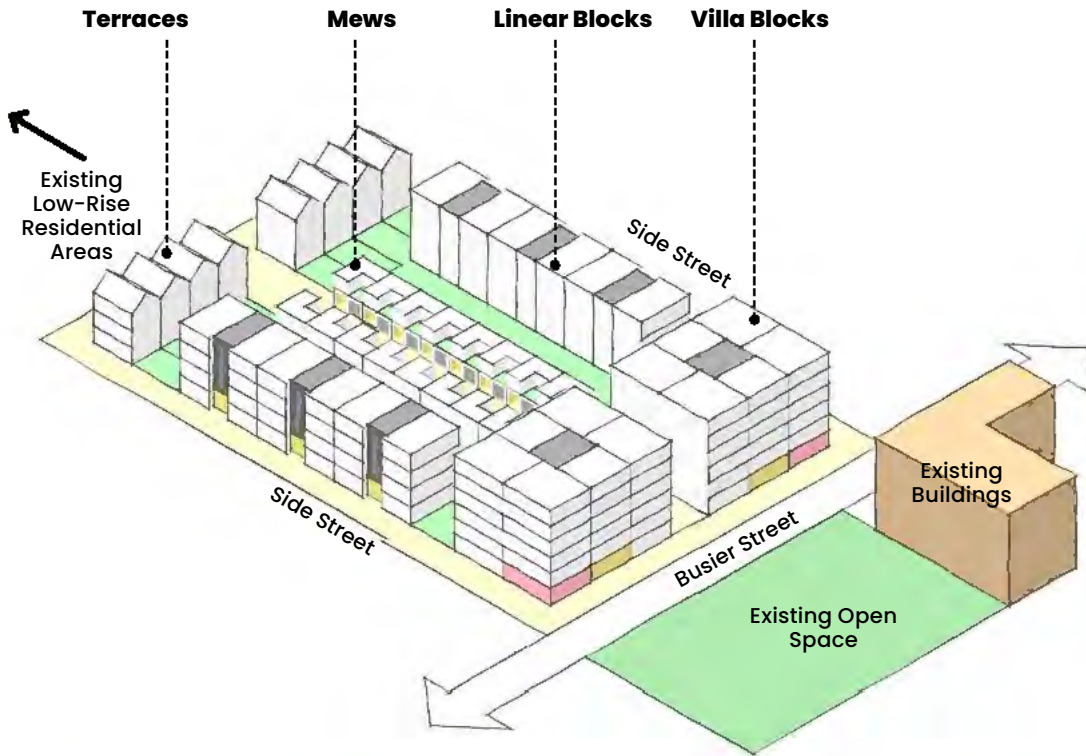

Applied Example 2

Approx 330dph, Floor Area Ratio 3.2

The site below is 105 x 80m, adjoining an existing High Street of 3-4 storeys linking through to an existing open space. The example transitions from the existing area by building heights from the High Street with fine-grain buildings into the centre of the new neighbourhood. A tower is located adjacent to new public realm at the centre of the neighbourhood. Coarser grain Villa Blocks overlook the open space.

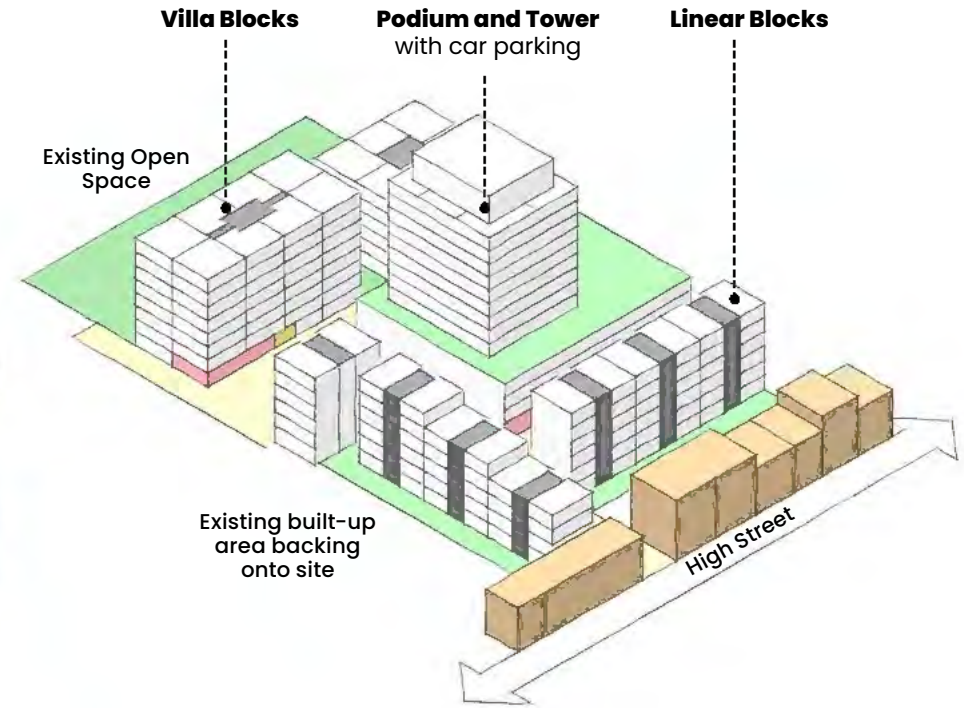

- Public Realm
- Gardens
- Commercial Space
- Public Open Space
- Entrances
- Parking
- Internal Circulation
- Existing Built Form

4.2.2.3 TALL BUILDING DESIGN REQUIREMENTS

When designed well, tall buildings can make valuable contributions to the character of a place, can accommodate significant numbers of new dwellings and can be positive new landmarks.

Tall buildings are defined in Staines-upon-Thames and Sunbury Cross as buildings over 8 storeys (around 24m).

The generally acceptable locations for tall buildings in Staines-upon-Thames and Sunbury Cross are set out in the heights plans in the Areas of Change coding in Chapter 5. They are located so as to:

- Respect the scale of existing streets and areas that are valued and form part of the identity of place
- Be within coherent new neighbourhoods, following the overall approach to **massing** set out earlier in this section, creating an overall rhythm of height variation across the town centre, with taller heights grouped together
- Be adjacent to spaces that can ‘absorb’ their scale

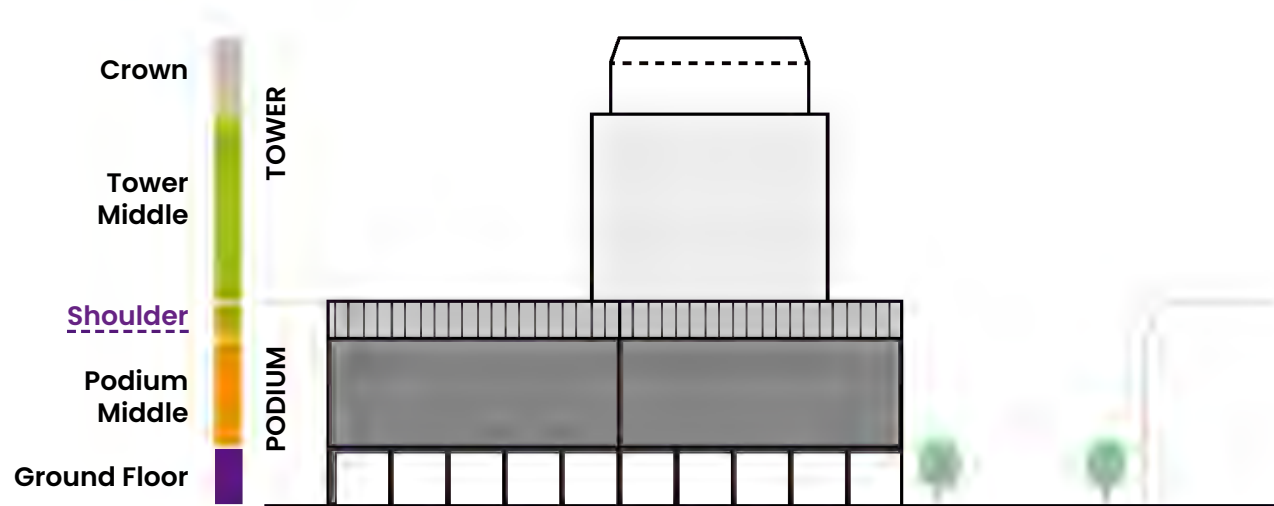

Each of the distinct parts of a tall building **must** be designed as set out below and in the principles set out on the following page..

Ground Floor	Podium Middle	Shoulder	Tower Middle	Crown
Activated ground floor relating strongly to street/ public realm	Main part of street facade elevation	Visibly differentiated top of street facade	Set back mass of tower, arranged to not dominate street	Visibly differentiated top of the building for longer views
Taller heights (typically 4.3m) to provide future flexibility of use	Balconies facing street inset or partially inset	Reduced storey height or levels of glazing to ‘cap’ facade	Balconies inset	Plant integrated within roof design
High levels of glazing when commercial uses specified	High levels of detailing and articulation to ensure visual interest	Maximum height to ensure visual connection between floor and street (typically 8 storeys, appx 24m)	Set tower back from plot edge	‘Penthouse’ accommodation can be incorporated within crown



Taller buildings have their place but must not overwhelm streets having an existing traditional character.

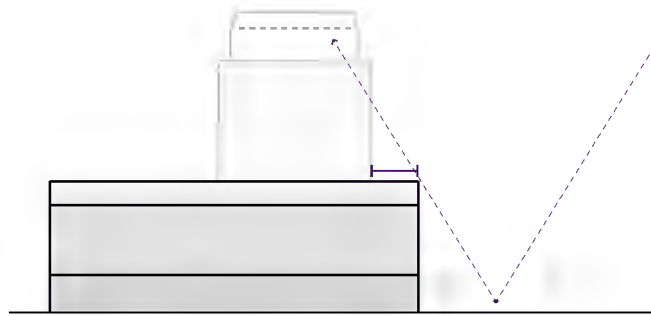
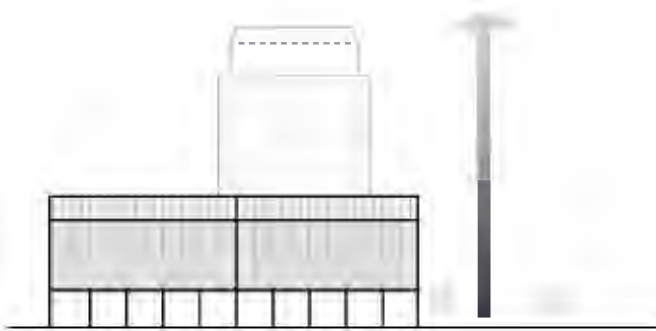

4.2.2.3a Breaking Up Massing

Facades for podium/base buildings **must** be broken up through vertical articulation such as pillars, changes in material and other architectural features to match the prevailing grain of the street and area.

Material choices **must** ensure that the tower is visually subservient to the base. This is usually achieved through selecting a paler material that recedes when viewed from the street, and the design of façades to be less visually prominent.

If needed to fit the prevailing urban grain, podium/bases **should** be designed so as to appear to be two or more independent buildings.

4.2.2.3b Scale Of The Street

The use of a setback and 'shoulder' for the tower element of a taller building creates a street environment that is not overwhelmed by the massing of the tower.

Shoulder heights on existing streets **must** be set at or one storey above the prevailing heights. For new streets, shoulder heights are a maximum of 8storeys (approx 24m).

Setbacks **must** be a minimum of 3m but larger setbacks are encouraged, and the impact of a tower on the existing street scale and townscape will be assessed on a site-by-site basis.

4.2.2.3c Microclimate

Taller buildings can have significant effects on wind and sunlight at street level and in the surroundings.

Sunlight analysis **must** be undertaken to demonstrate that surrounding public spaces and dwellings retain access to sunlight for at least two hours per day during winter.

With an appropriate setback above a podium, 'wind tunnel' effects on public spaces are likely to be limited. Stepped, rounded or chamfered corners and massing are approaches that can be used to further reduce these effects at ground level.

4.2.3 Open Spaces

Open spaces in town centre neighbourhoods are vital relief for relaxation, socialising, nature and general health and wellbeing. Spelthorne's town centres generally have few public open spaces, and new development should maximise opportunities to include them, as well as providing space for residents to use.

DESIGN AIMS

Open Spaces in Town Centre Neighbourhoods will:

- Be safe and secure (and perceived to be so) for all user groups at all times
- Encourage physical activity, enable social interaction, provide access to nature and be inclusive
- Be of a variety of types appropriate to a town centre context and their intended use
- Include provision of shared amenity space for residents to use regardless of tenure
- Take opportunities to improve connectivity of development with the nearby natural environment

4.2.3.1 NEIGHBOURHOOD OPEN SPACE APPROACH

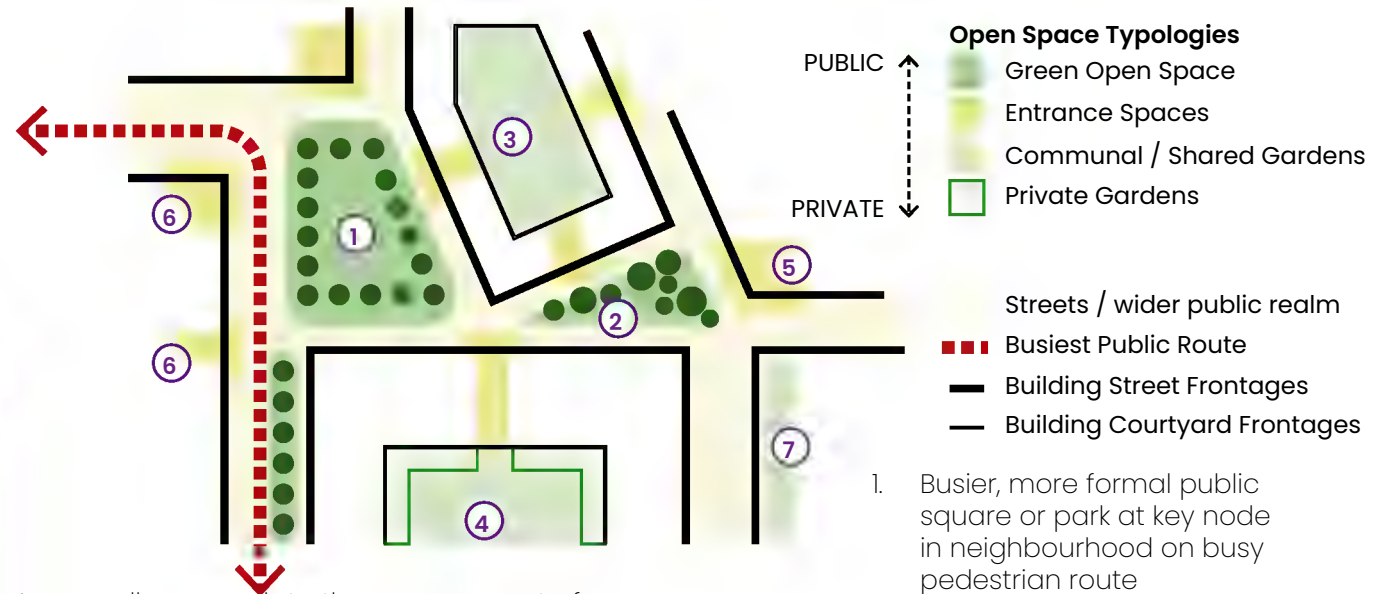

An overall approach to the arrangement of open spaces in relation to each other and built form is set out in the diagram above. Each typology has detailed requirements on following pages.

New neighbourhoods may be delivered through a number of different sites. The overall principles will apply across sites, and are defined in detail in Chapter 5, 'Areas of Change'.

New town centre neighbourhoods **must**:

- Clearly define public and private spaces
- Ensure the intended character of open spaces reflects the activity of connecting streets, with busier spaces on busier streets

Open Space Typologies

- Green Open Space
- Entrance Spaces
- Communal / Shared Gardens
- Private Gardens

- Streets / wider public realm
- Busiest Public Route
- Building Street Frontages
- Building Courtyard Frontages

1. Busier, more formal public square or park at key node in neighbourhood on busy pedestrian route
2. Quieter neighbourhood incidental 'pocket park' away from main routes, with seating, informal play areas and a less formal character
3. Ground-level communal garden
4. Podium-level communal garden with private gardens for dwellings at edges
5. Building entrances at key corners and onto open spaces
6. Regular entrances to activate street
7. Shared roof terrace in setback area above street



Green spaces form a vital part of Spelthorne's identity, but the town centres lack good provision.

4.2.3.2 SAFETY AND SECURITY

Open space typologies are defined on a continuum of public to private use, which defines their role and key uses within an open space network.

All open space **must** implement key principles set out in Secured by Design to ensure spaces have good passive surveillance and do not encourage anti-social behaviour through layout and detailed design.

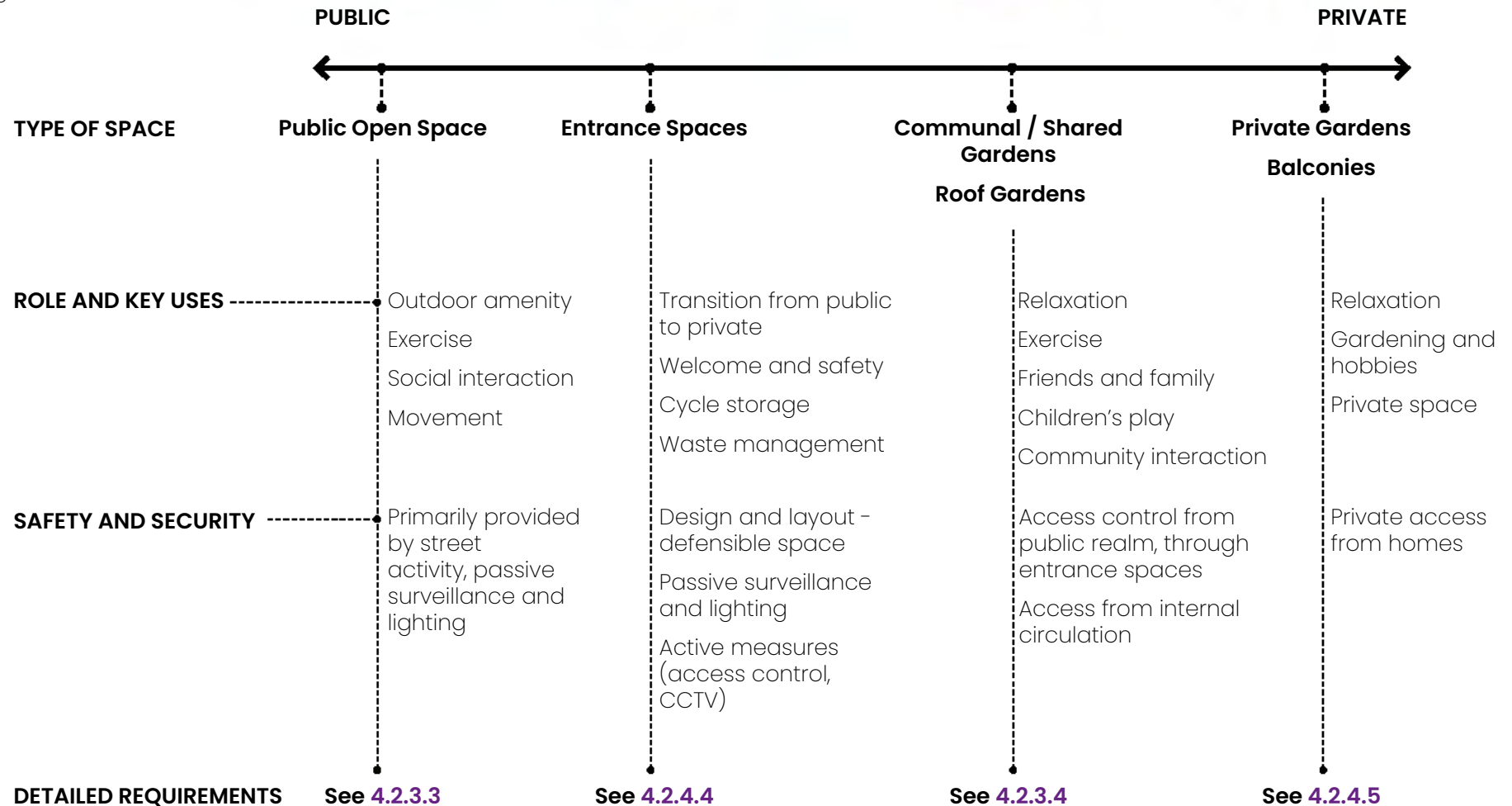

4.2.3.3 PUBLIC OPEN SPACES

Public open spaces **must**:

- Be overlooked by surrounding built form, with **active frontages** at ground level
- Provide seating at least once every 50m along active travel routes
- Provide visitor cycle parking
- Be universally accessible to all abilities
- Be well-lit with no concealed spaces
- Include planting and trees for shade and shelter
- Include surface water management systems and solutions including permeable paving, permeable planted areas, rills, drains and other water management features
- Connect to and extend active travel routes through the space to LTN 1/20 standards
- Be protected from vehicle traffic through bollards or other boundary treatments

Depending on character and intended use, public open spaces **could** include:

- Events space in larger, busier open spaces
- Gathering and socialising spaces
- Community garden space in quieter, neighbourhood spaces
- Informal and designated play areas, outdoor gyms and trim trails

Suitable public open space typologies and key design requirements within the Town Centre Neighbourhoods area type are set out on the following page.

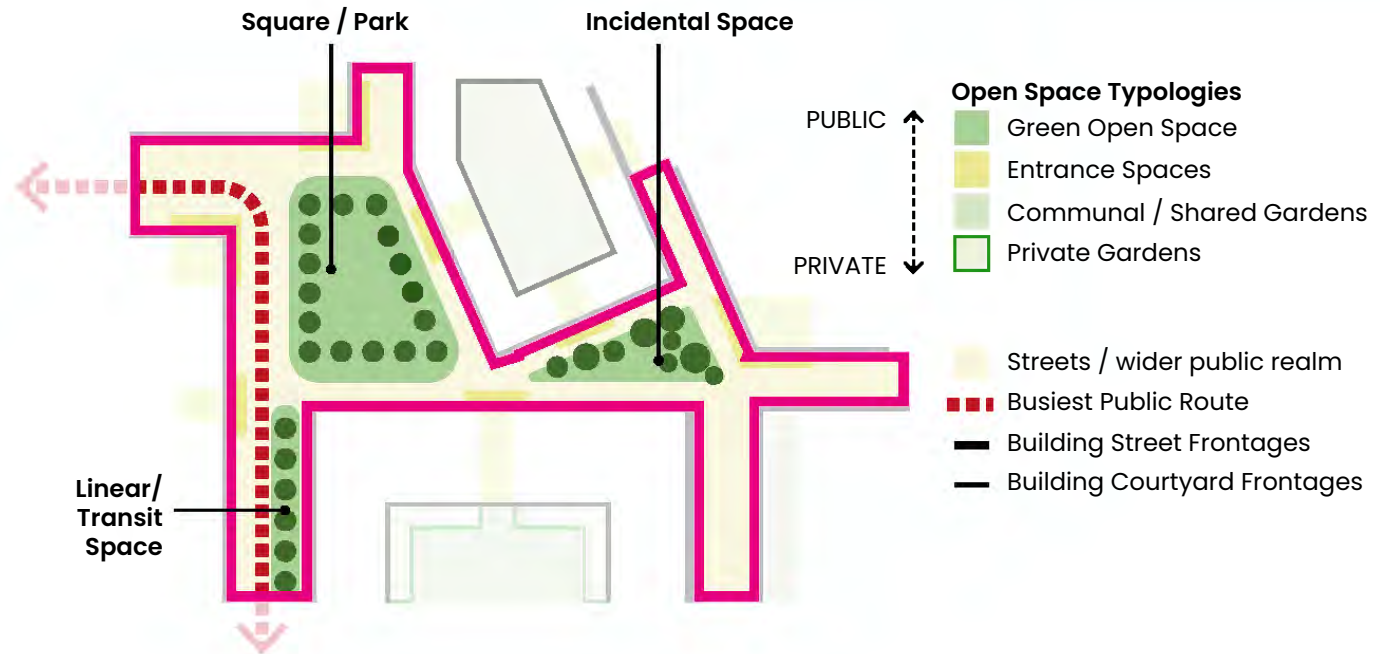

'Play on the way' in streets



Seating, movement, gathering and relaxation space as an integral part of landscape design



Flexible use of existing open space for events and temporary seating

4.2.3.3a Squares and Parks



Located at key nodes within the town centre active travel movement network. Squares and parks **must** have:

- High levels of enclosure by surrounding built form, with a width:height aspect ratio of between 1.5:1 and 3:1
- A mix of hard and soft landscaping, seating, trees for shade and a focal point of interest
- Typical maximum dimensions of around 50-70m along the edges

4.2.3.3b Courtyards, Incidental Spaces and Pocket Parks



Courtyards, incidental spaces and pocket parks enclosed by built form **must**:

- Be used positively for functions such as cycle parking, surface water management, informal play space and biodiversity enhancement
- Be smaller in size than squares and parks, and typically quieter in feel and character
- Have passive surveillance and good lighting
- Have sufficient daylight to avoid spaces becoming dark and unpleasant

4.2.3.3c Linear and Transit Spaces



Linear parks and extended green open spaces can successfully bring together development along key active travel routes. They **must**:

- Have high levels of enclosure by surrounding built form with **active frontages** throughout
- Have a maximum width of around 30-40m
- Be varied in character along their length to ensure legibility
- Clearly delineate through active travel routes

4.2.3.4 SHARED/COMMUNAL OPEN SPACES

Shared open spaces **must**:

- Be universally accessible to all abilities
- Be overlooked by surrounding dwellings, with levels of lighting so as not to disturb residents
- Be separated from residential units by a minimum of 1.5m of defensible buffer space (e.g. a private garden) or boundary treatment to provide privacy
- Provide regular seating, mixed in groups for socialising and individually for relaxation
- Include planting and trees for shade and shelter, and to provide permeable surfaces
- Achieve a minimum of 2hrs sunlight covering at least 50% of their usable area on March 21st
- Be a minimum of 21m wide to provide privacy between dwellings. Subject to daylight requirements, this may be reduced if windows and built form are arranged in a manner so as to provide privacy between facing dwellings.

Depending on character and intended use, shared open spaces **could** include:

- A mix of different gathering and socialising spaces, and more secluded spaces for relaxation
- Community gardens and food production
- Informal play areas, outdoor gym equipment
- New habitats and natural spaces

Shared open space typologies and requirements within the Town Centre Neighbourhoods area type are set out on the following page.

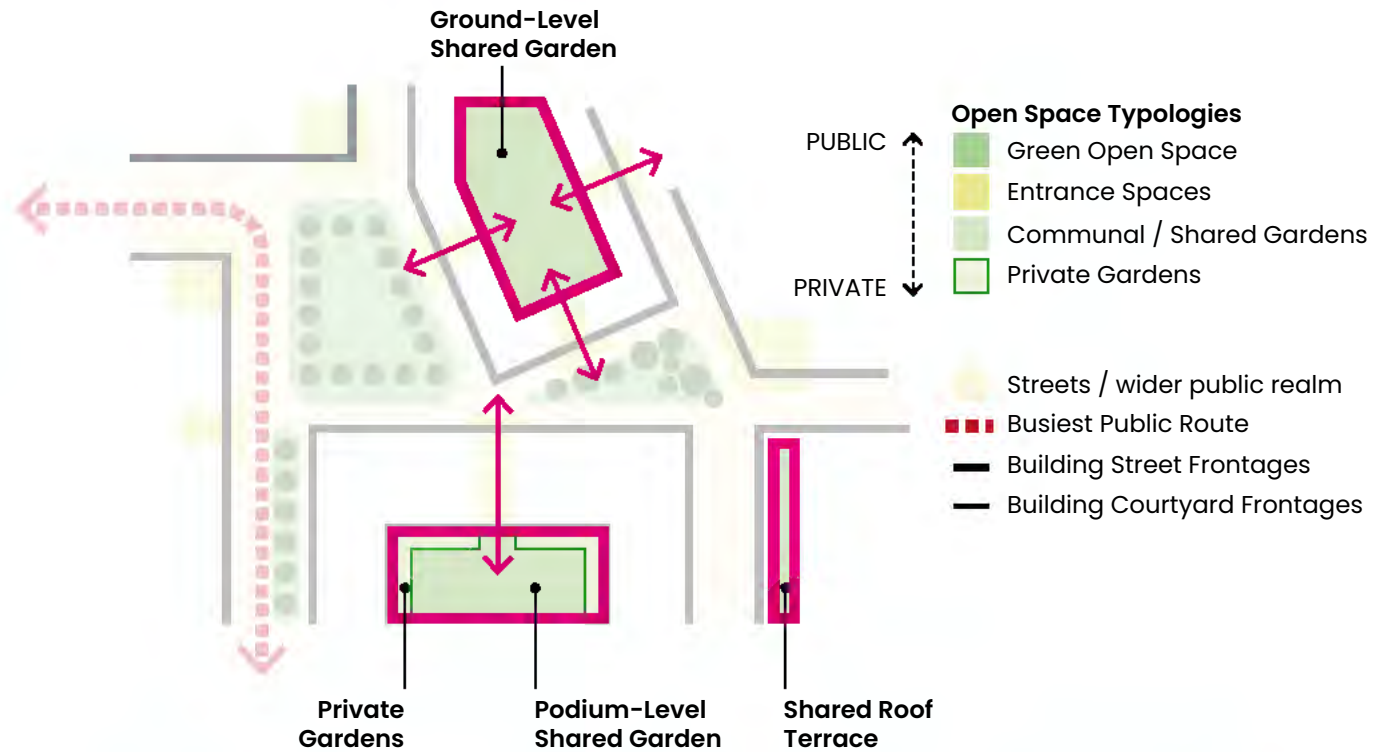

Private garden space facing shared community garden



Shared roof terrace space sheltered from prevailing winds



Seating arranged in groups to encourage socialising

4.2.3.4a Ground-Level Gardens



4.2.3.4b Podium Gardens



4.2.3.4c Roof Gardens and Terraces



Ground-level gardens can be both communal or provide access to the public with sufficient design consideration. They **must**:

- Be separated from the public realm by built form or other features that provide privacy, access control and visual separation
- Have a clear buffer and boundary treatment of up to 1.2m high to homes fronting or backing onto the space

Communal gardens sat on top of podiums that house parking, servicing or other development are an efficient way of using space. They **must**:

- Be planted with plants with smaller rooting requirements
- Be connected directly to vertical circulation and entrances in surrounding buildings
- Have a clear buffer and boundary treatment of up to 1m high to homes fronting or backing onto the space

Roof gardens and terraces can be both communal or private spaces. They **must**:

- Be sheltered (by surrounding built form or other features in their design) from prevailing and northern winds, and make the most of solar gain through their aspect
- Be planted with species of a lower height that can survive at height and with less soil

4.2.3.5 LANDSCAPE CHARACTER

Town centre neighbourhoods will typically have a more urban, managed character than suburban areas. Busier areas will have a high proportion of hard landscape. There will be opportunities to incorporate softer landscape and planting throughout, and smaller, incidental spaces should be greener and calmer than busier spaces.

The integration of street furniture so as to avoid clutter and complement the overall landscape scheme is an important component of the landscape character of town centre neighbourhoods.

Material selection and the design of all features in the adopted public realm **must** be in compliance with the Surrey Healthy Streets Design Code.

4.2.3.5a Hard Landscape

Hard landscape materials **must** be selected to be long-life, attractive and delineate different uses effectively.



Changes in material can help to delineate movement areas from seating, utility, gathering and other spaces.



Patterns within public realm surfacing at key nodes can reinforce importance of location and memorability

4.2.3.5c Street Furniture



Seating **could** be integrated with planting beds



Changes in level **could** be informal seating areas



Bollard **could** also provide lighting



Street furniture **should** be installed where it does not block movement

4.2.3.5b Soft Landscape

Soft landscape features **must** be incorporated throughout the public realm to provide new habitats, shade, cooling, surface water absorption and to soften the appearance of the built environment.



Planted beds can separate different spaces within the public realm.



Planted strips can provide flexible areas to accommodate uses that activate a street, such as seating or informal play equipment

Species selection **should** be diverse, prioritising native and locally appropriate species to enhance resilience to climate change, support biodiversity, and reduce the risk of invasive species.

Management and maintenance **should** be minimised where possible.

4.2.3.5d Street Trees

All streets **must** be tree-lined. In general trees will be integrated with hard landscape or planted beds and associated street furniture within the street scene. Suitable approaches include:



Trees installed within hard landscape



Trees installed within small planted areas



Trees installed within planting beds and street furniture

Trees **must** have sufficient space to grow and thrive, following guidance set out by the Trees and Design Action Group (see reference in Chapter 6).

Species selection **should** be diverse, prioritising native and locally appropriate species to enhance resilience to climate change, support biodiversity, and reduce the risk of invasive species.

4.2.3.5e Surface Water Drainage Features

All development **must** manage surface water through the use of Sustainable Drainage Systems (SuDS). Suitable design features include:



Source Control / Initial Absorption Features

- Street 'rain gardens'
- Planted verges and general soft landscape cover
- Green roofs and walls
- Permeable surfaces and details

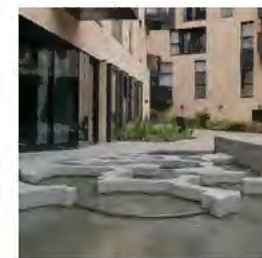

Conveyancing Features

- Rills and other channels
- Planted street swales
- Incorporation into public realm features



Attenuation Features

- Larger rain garden features as part of incidental spaces
- Underground crate storage (where no other options available)

4.2.4 Homes and Practicalities

Town centre dwellings should be welcoming, safe and convenient places to live, with all the pleasures and conveniences of modern urban living to hand. Enough space, a mix of homes and well-designed essentials will make new homes in town centres built to last.

4.2.4.1 SPACE STANDARDS

All homes **must** be at least the sizes specified in the Nationally Described Space Standards ([Local Plan](#) policy H1). The March 2015 standards are set out below for reference.

Dwellings **must** offer a mix of flexible internal storage and secure outdoor areas of storage for items such as pushchairs, scooter and, helmets. In apartment buildings such larger storage areas are best accommodated adjacent to dwelling front doors.

DESIGN AIMS

Homes in Town Centre Neighbourhoods will:

- Be sized to Nationally Described Space Standards and include a flexible mix of storage space
- Be of a mix of dwelling types to create inclusive and balanced new places
- Be mostly dual-aspect dwellings
- Have safe, welcoming entrances from the street with essentials such as waste, recycling and cycle storage close to the front door
- Provide sufficient private outdoor amenity space for all residents
- Accommodate vehicle and cycle parking appropriately, with the potential for town centre homes to be car-free

Number of bedrooms	Number of bed spaces (persons)	1 storey dwellings (e.g. apartments) (m ²)	2 storey dwellings (e.g. houses / duplexes) (m ²)	3 storey dwellings (e.g. houses) (m ²)	Built-in storage (m ²)
1	1	39			1.0
	2	50	58		1.5
2	3	61	70		2.0
	4	70	79		
3	4	74	84	90	2.5
	5	86	93	99	
	6	95	102	108	
4	5	90	97	103	3.0
	6	99	106	112	
	7	108	115	121	
	8	117	124	130	
5	6	103	110	116	3.5
	7	112	119	125	
	8	121	128	134	
6	7	116	123	129	4.0
	8	125	132	138	



Spelthorne's communities want to see spacious and high quality homes provided for new residents.

4.2.4.2 MIX OF HOMES

A wide mix of types of dwelling are encouraged in all developments. These are closely related to the Development Typologies in 'Scale and Massing'.

Dwellings **must**:

- Be designed to be tenure-blind with no differentiation between affordable and market tenures.
- Not have 'poor doors' or other selectively gated forms of development.

4.2.4.3 DWELLING ASPECT

Dwellings which have dual aspects have several benefits for residents, including:

- Sunlight at multiple times of day for passive heating and access to natural daylight
- Passive cooling in hotter weather from breezes through the building

Development **must**:

- Maximise dual aspect dwellings
- Size dwellings with aspects on opposing sides to be no more than 12m deep
- Size dwellings with aspects at right angles to be no more than 8m deep from a window
- Size single-aspect dwellings to be no more than 8m deep
- Orient single-aspect dwellings along an east/west direction to ensure access to daylight without excessive build-up of heat.

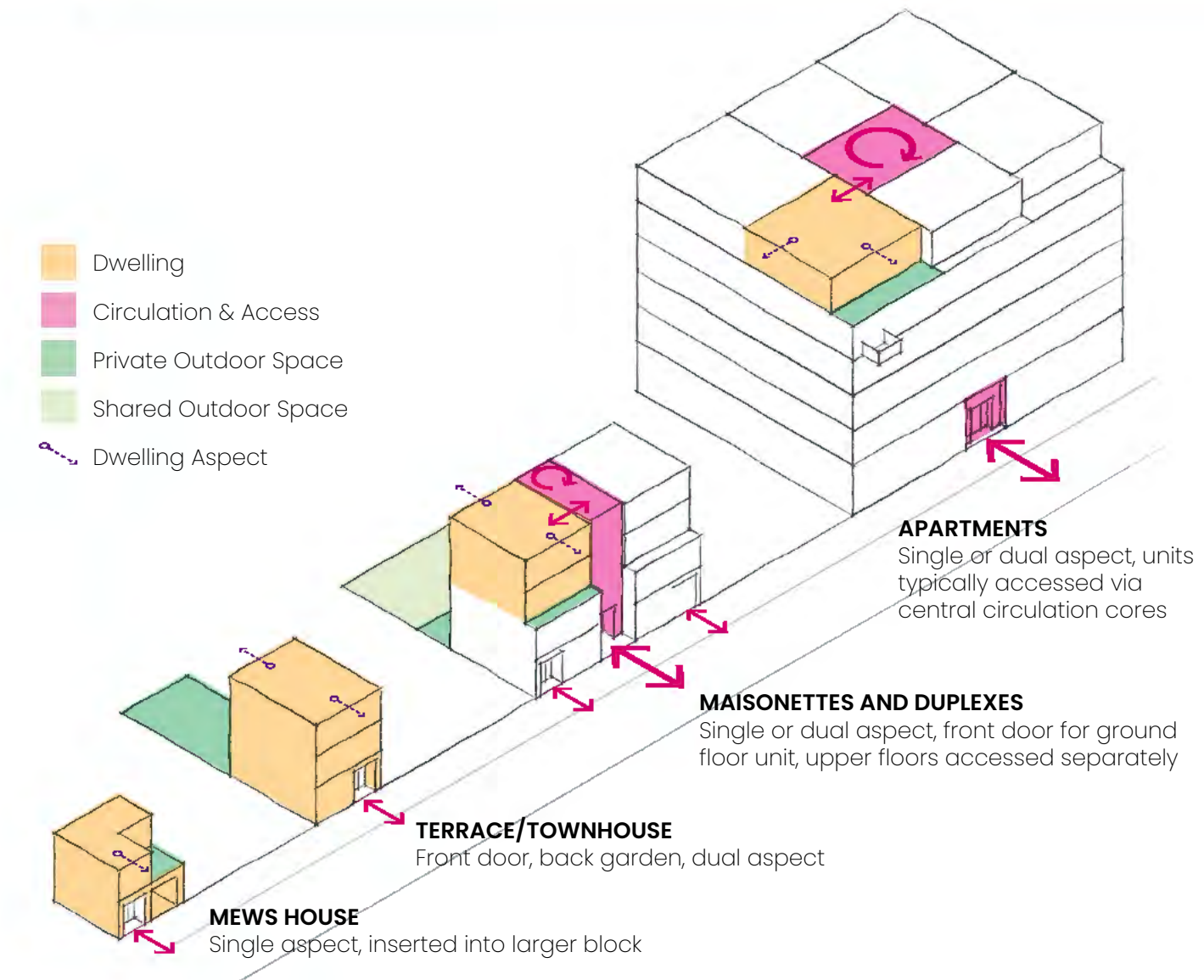

Types of Dwelling, Aspect, Access and Arrangement

4.2.4.4 RESIDENTIAL ENTRANCES AND CIRCULATION

Entrances to residential buildings are frequently used, functional spaces that also set the tone for a development. They should be accessible, safe, welcoming and convenient, with daily uses such as cycle storage and waste disposal close by.

Within fluvial flood risk areas, all entrances, shared or private, **must** have a universally accessible dry pedestrian evacuation route.

Detailed requirements for building security are set out in Secured by Design guidance.

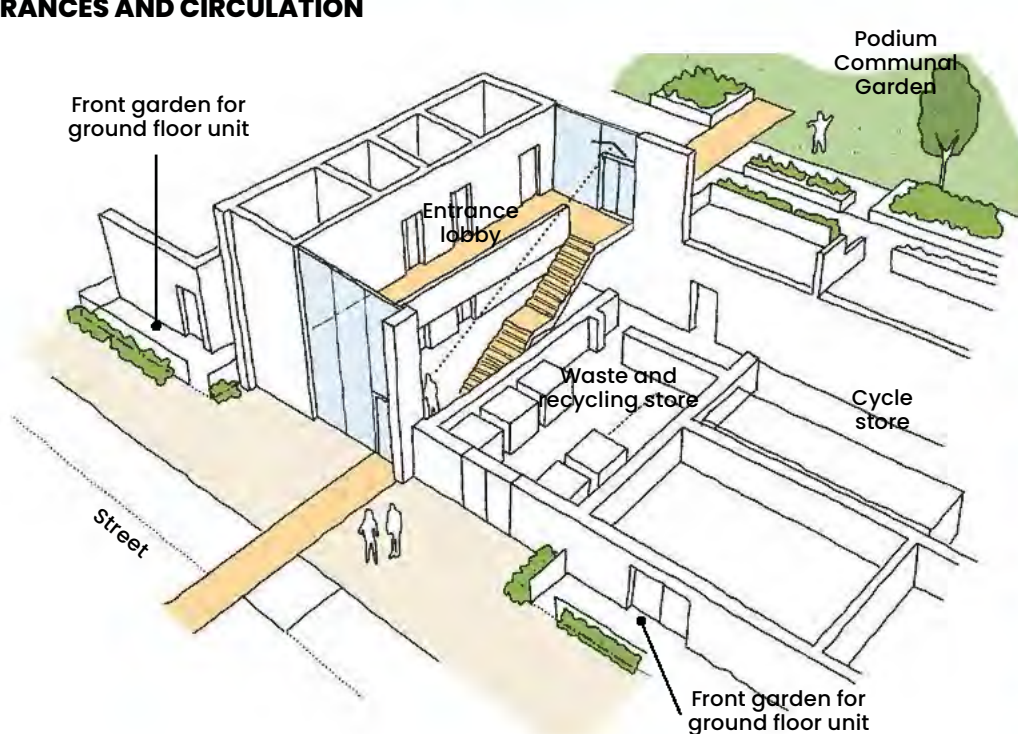

Entrance example - Podium Garden

4.2.4.4a Shared Entrances

Shared residential entrances **must**:

- Be located with a front door onto the street for legibility and to activate the street.
- Have an accessible level access entrance area which is safe, welcoming, durable, well-lit and at least partially glazed onto the street.
- Have lifts and stairs within sight of the entrance area or clearly signposted.
- Have external windows for daylight and ventilation.
- Include facilities for deliveries that does not require giving access to the whole building

Shared entrances **should** locate a range of key uses close by.

- Secure residents' cycle parking, which may be accessed from the communal entrance lobby as long as there is a direct access off the lobby, or from a direct secure link to the street
- Waste and recycling stores should be located as close to residential entrances as possible, with an access to the street to enable possible collection directly from the store, rather than as a managed collection.
- Waste and recycling stores should not connect to the core internally as this poses a security risk and allows smells to enter the building.



4.2.4.4b Private Entrances

Single-dwelling residential entrances **must**:

- Face the street or shared courtyard space for legibility and to activate the street/space.
- Be provided for ground-floor apartments and maisonettes from the street.
- Provide a sheltered, inset defensible space adjacent to the front door of at least 1m deep by 1.5m wide
- Include a covered space to store bins
- Include secure space to store cycles
- Be accessible to users of all abilities with a variety of mobility needs

4.2.4.5 PRIVATE AMENITY SPACES

4.2.4.5a Balconies

Balconies **must:**

- Be provided for all dwellings that do not have other forms of private outdoor space
- Have a minimum depth of 1500mm
- Have a minimum of 5m² of private outdoor space for all 2 person dwellings and an extra 1m² provided for each additional occupant.
- Have level access from a habitable room, ideally a living room or living area
- Comply with the acceptable locations for different forms of balcony set out on the right
- Where inset, be able to be at least partially closed from wind and rain
- Where overhanging, include a privacy screen between dwellings of 1.8m high

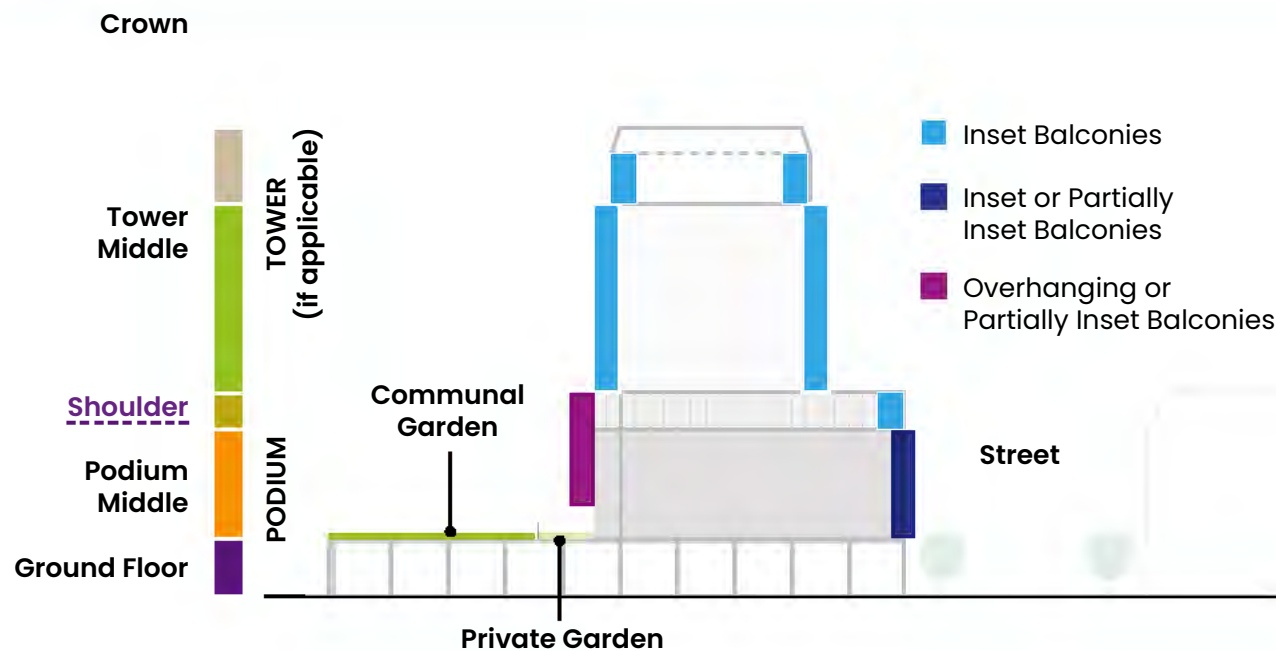

Private amenity space in town centre neighbourhoods may be provided by balconies (or roof terraces), or in private gardens, which may back onto communal gardens.

4.2.4.5b Private Garden Space

Private garden spaces **must:**

- Directly adjoin and have level access from the dwelling's living area
- Have a minimum depth of 2m
- Have a minimum of 5m² of private outdoor space for all 2 person dwellings and an extra 1m² provided for each additional occupant.
- Be the same width of the dwelling it serves
- Be clearly identified by boundary treatments, including railings, low wall, a hedge
- Have a privacy screen between dwellings of up to 1.8m



Privacy screens on protruding balconies



Private gardens between dwellings and communal garden

4.2.4.6 VEHICLE AND CYCLE PARKING

Living close to the town centre offers an opportunity to encourage active travel as a regular choice over frequent use of the car. In town centre neighbourhoods the aim should be to have fewer than one resident parking space per dwelling, and may have none at all.

Car parking, where it needs to be provided, needs to be accommodated using an appropriate typology that limits the impact on the surrounding area and street scene.

All town centre development **must**:

- Include visitor cycle parking
- Include convenient and secure cycle parking for residents, at a provision level of 1 space per 1-2 bed dwelling or 2 spaces per 3+ bed dwelling
- Include car parking designed to the requirements for the appropriate typology as set out on the following page
- Provide at least 10% of car parking spaces as disabled spaces within 50m of the relevant building entrance
- Provide a fast EV charging point for each dwelling
- Provide parking spaces to the dimensional requirements set out in the Surrey Healthy Streets Design Code

All town centre development **should**:

- Identify space of at least 2.5m x 6.0m close to shared residential entrances for delivery vans to park and drop off items
- Identify cycle parking space close to retail units that may host cafes, restaurants and food takeaways for delivery cycles to park when picking up items

4.2.4.6a Visitor Cycle Parking

Visitor cycle parking **must**:

- Be located close to entrances of residential and commercial buildings, or at accessible points within courtyards
- Be overlooked and well-lit
- Be covered when not on the street
- Be of typical Sheffield stand construction



Visitor cycle parking within the public realm



Visitor cycle parking within a residential courtyard

4.2.4.6b Residents' Cycle Parking

Residents' cycle parking **must**:

- Be located close to entrances of residential and commercial buildings, or at accessible points within courtyards
- Be secure and lockable, with no visibility into the parking area from the street
- Be overlooked and well-lit
- Be enclosed, dry and protected from the weather
- Be more convenient to access for daily journeys than the car park
- Be accessible to users of all abilities with a variety of mobility needs

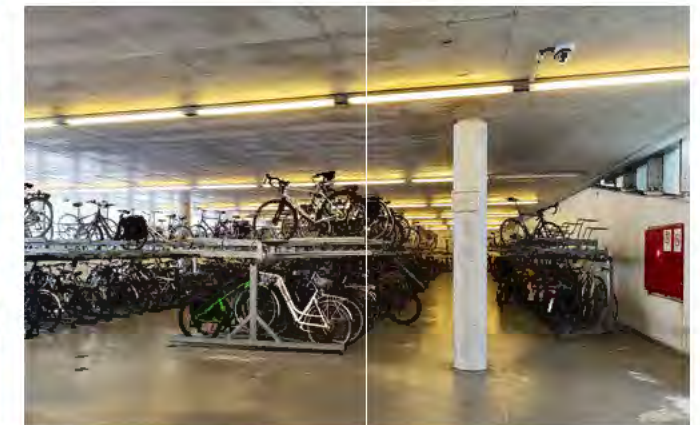

Secure cycle parking garage

4.2.4.6c Underground Parking

Underground parking offers a space-saving option for town centre car parking. They **must**:

- Be well-lit, ideally with some natural light and secure
- Be well-ventilated
- Not compromise the provision of high-quality trees and planting in communal gardens above them
- Be accessed from an entrance on a side or service street, rather than from a main street
- Have direct, secured access to internal circulation cores
- Have no negative impact on groundwater flows through an evidenced engineering solution, demonstrated as part of the planning application
- Be accessible to users of all abilities with a variety of mobility needs

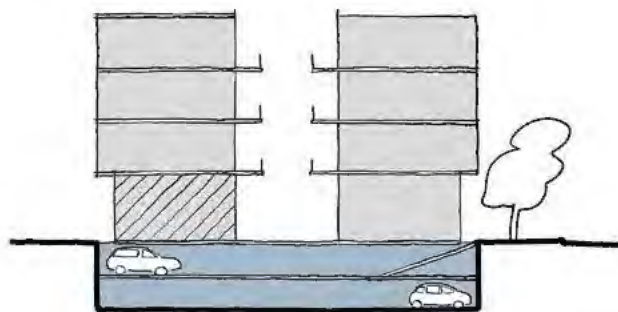

4.2.4.6d Podium Parking

Podium parking offers a flexible option for town centre car parking within higher-density developments. They **must**:

- Be well-lit, ideally with some natural light, and secure
- Be well-ventilated
- Not compromise the provision of high-quality trees and planting in communal gardens above them
- Be accessed from an entrance on a side or service street, rather than from a main street
- Have direct, secured access to internal circulation cores
- Have no negative impact on groundwater flows through an evidenced engineering solution, demonstrated as part of the planning application
- Be accessible to users of all abilities with a variety of mobility needs

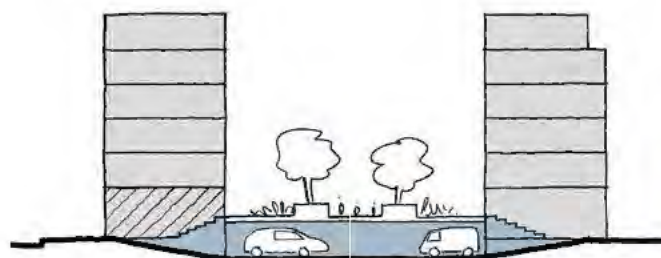

4.2.4.6e Integrated Parking



For typologies such as mews or terrace houses, integrated parking within the building can be a good option. Homes with integrated parking **must**:

- have no more than 50% of the frontage used for parking access
- at least one street-facing window on the ground floor to provide passive surveillance

4.2.4.6f Surface or On-Street Parking

Surface or on-street car parking **must** only be used in very limited circumstances, for example to provide disabled, visitor or accessible parking spaces.

Any surface or on-street parking **must**:

- Incorporate trees or planting at least once every five parking spaces
- Be surfaced with permeable paving



4.2.5 Detail and Richness

Town centre buildings are part of the identity of a place. New buildings can complement their surroundings by being attractive, having visual richness at all scales and fitting with the materiality of the context.

DESIGN AIMS

Town Centre Neighbourhoods **will**:

- Be designed to enhance the townscape of Spelthorne's places, providing interest, legibility and identity
- Have buildings with façades and elevations with richness, depth and detail, adopting an approach appropriate to the chosen architectural language of the building

4.2.5.1 TOWNSCAPE

'Townscape' is a term that characterises the richness and quality of the built environment, and how it can be successfully tied together.

Town Centre Neighbourhoods will have a rich and attractive townscape. They **should** make use of features either seen in Spelthorne or that would be suitable for the town centre context.

Screened & Terminated Vistas



The end of a view is terminated by a marker building. Using trees to screen the vista increases the sense of distance.

Projection & Recession



A building line with bays, variation and intricacy rather than a single flat frontage.

Enclosure



Spaces which are surrounded by built form, providing a quieter 'escape' from adjacent busier streets that are more open.

Incident & Punctuation



Features breaking up the street view or interrupting the alignment of the street to create interest and separation.

Deflection



Views partially terminated by a building set at an angle, suggesting a further space round the corner.

Narrowing and Views Through



Differentiating between two spaces by emphasising the transition through constricting the width between the two.



Rich, detailed building façades are popular with the community.

4.2.5.2 DISTINCTIVE BUILDINGS

The street environment **must** be easy to navigate for those who may be less familiar with it, and easy to remember for those who are. The arrangement and prominence of buildings relative to one another make a valuable contribution to the legibility, memorability and cohesiveness of the overall townscape of Spelthorne's town centres.

'Legibility' is the ability of people to 'read' a street environment to understand how to navigate a place successfully without resorting to signage or maps.

Two key types of building should be considered to aid legibility and townscape in important locations: **marker buildings** and **landmark buildings**.

Marker and landmark buildings will be important and long-lasting parts of the overall townscape and should be considered with care. The **design process** for such buildings **could** make use of:

- Architectural design competitions
- Design review panels that include community representatives

4.2.5.2a Marker Buildings

Marker buildings are memorable buildings that stand out from the surrounding built form. They can help people to navigate and make the townscape more distinctive and interesting.

Marker buildings **should** be located:

- To terminate key views along streets
- At nodes, public spaces or meeting points
- To draw attention to key entrances or uses within an arrangement of buildings

Marker buildings **must**:

- Be of similar grain and dimensions to surrounding built form and complement the wider townscape.
- Be differentiated and distinctive from surrounding built form through the use of detailing, materiality, architectural treatment or orientation.



Marker building terminating view along street

4.2.5.2b Landmark Buildings

Landmark buildings are prominent buildings that are easily recognisable and have significant cultural or historical value.

Landmark buildings should be used sparingly in development.

Landmark buildings **should** be located:

- At major nodes or public spaces within a town centre
- As an anchoring focal point within new neighbourhoods, housing distinctive uses that define the new neighbourhood

Landmark buildings **must**:

- Include distinctive, town-wide uses of wider importance, not just residential use
- Be of distinctive and exceptional architectural quality, materiality and **massing** approach, differentiated from their surroundings



Landmark building in prominent location

4.2.5.3 DESIGN OF ELEVATIONS

Buildings need to have variation, depth and texture on their elevations, as well as façades that are proportioned well and reflect features in the local context. This can be accomplished in traditional and contemporary ways.

Key elevation aspects for town centre neighbourhood buildings are:

- Overall facade composition
- Arrangement of windows
- Window detailing and reveal depths
- Treatment of balconies
- Corners of buildings
- Roofs and building tops

Example implementation of design code elevation requirements



String course detail to separate roof

Visually subservient top of the building, shorter window heights

Unified middle of elevation, prominent window surrounds

Textured and differentiated base

Boundary treatment matching overall materiality

4.2.5.3a Facade Structure: Base, Middle and Top

Buildings **must**:

- Have a base, middle and top floors that are differentiated visually through the use of materials and proportional heights
- Have a base that is traditionally treated with a highly textured materiality, e.g. rough-hewn brick or other visually textured materials, of one or two storeys, with proportionally taller storey heights
- Treat each elevational aspect of the building according to its setting, which may differ across the same building



4.2.5.3b Proportions

The overall composition of an elevation **must**:

- Have proportions informed by the general context of the site and the immediate surrounding environment. For example, buildings in a fine grained immediate context utilising a tall, narrow, vertical proportion.
- Emphasise horizontal or vertical components of the facade to reflect context and grain of building
- Have component parts (**massing** volumes, doors, windows etc) that clearly relate to each other in terms of size, position and separation

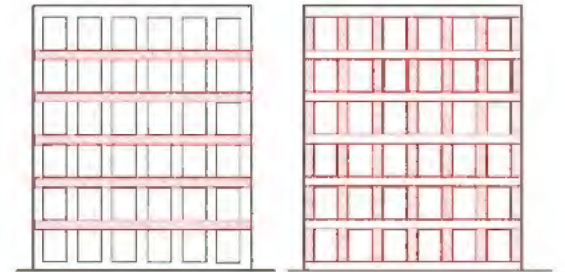

Emphasis on horizontal components of facade, visually widening and shortening building

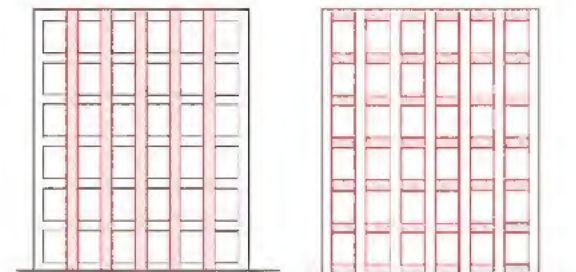

Emphasis on vertical components of facade, visually narrowing building

4.2.5.3c Building Tops and Roofs

The roofscape has an effect on both long-distance views of the town centre and the perception of buildings from the street. They terminate the elevation vertically and balance the overall composition. They can include dwellings and building plant.

Buildings in town centre neighbourhoods **must**:

- Distinguish the top of the building from the rest of its facade using one of the roof types specified on this page
- Adopt a roof that reflects the grain of the building as specified
- Incorporate any building plant within the design of the roof, so it is hidden from the street and distance views

Buildings in town centre neighbourhoods **could**:

- Include roof terraces within setbacks
- Include balconies within gable end roofs

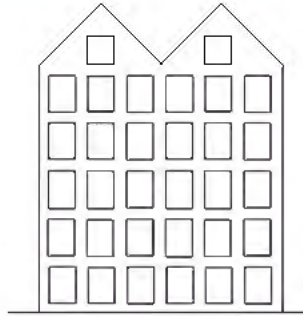

Pitched gable-end roof form potentially incorporating accommodation

Most appropriate for fine-grained buildings <10m wide



Mansard roof with or without dormers

Most appropriate for medium-grained buildings <20m wide

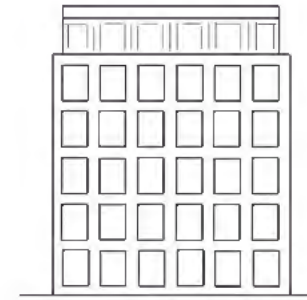

Setting back of upper storeys, with change in materials or window expression

Appropriate for coarser-grained buildings 15m+ wide

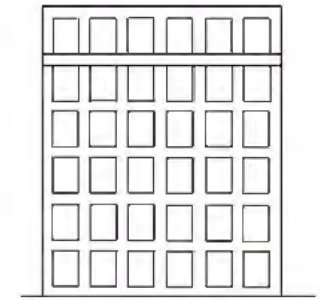
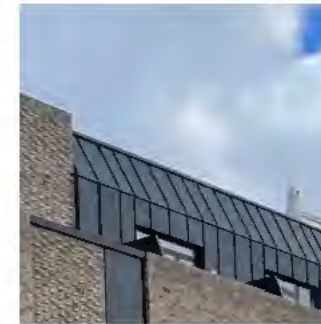

Separating horizontal element - cornice, string course, change of material or texture

Appropriate for coarser-grained buildings 15m+ wide



The skyline and tops of buildings are important to the community, especially when viewed from a distance.

4.2.5.3d Balconies

Balconies for apartments have a significant effect on how the elevation and resulting street scene are perceived.

In addition to the dimensional requirements set out under **TC-H5**, detailed design of balconies **must**:

- Ensure adequate daylight levels within the home when inset or partially inset balconies are used
- Have edge treatments that balance privacy for occupants, views out, and also provide screening of furniture etc when viewed from the public realm.
- Ensure shading to windows below, assisting with the avoidance of overheating issues.
- Be clad to all sides including the underside, to maintain a high quality appearance from all aspects.



Use of rich, complementary materials to unify balconies to facade



Corner inset balconies



Use of privacy screen that also provides shading to apartment and balcony



Use of inset balconies to break up facade

4.2.5.3e Corners

Buildings addressing street corners **must** have:

- Passive surveillance and **active frontages** facing both elevations

Street corners **could** include:

- Inset balconies
- Shared residential entrances
- Retail corner units
- Different material treatments to surrounding elevations
- A single storey rise in height
- A distinctive roof form



Differentiated corner



Rise in heights, distinct roof and corner entrance

4.2.5.3f Windows and Fenestration

Windows, window surrounds and other fenestration within an elevation **must**:

- Only use flush windows for ground floor retail
- Have other window reveals at least 75mm in depth to provide richness to the elevation, and deeper if the surrounding context has deeper depth of façades
- Balance the need for internal daylight penetration with thermal performance, overheating, privacy and views out.
- Have glazed coverage on façades that complies with the proportions set out in **4.2.6.1** under Climate Change and Sustainability.
- Achieve a well-proportioned facade, potentially through the use of a secondary grid of features within overall window reveals

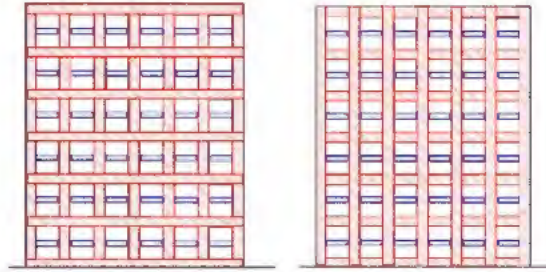

Secondary grid within window reveal to emphasise horizontal components of facade

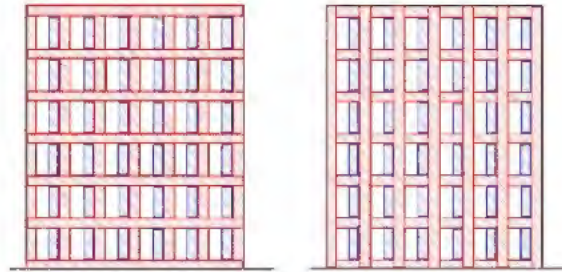

Secondary grid within window reveal to emphasise vertical components of facade

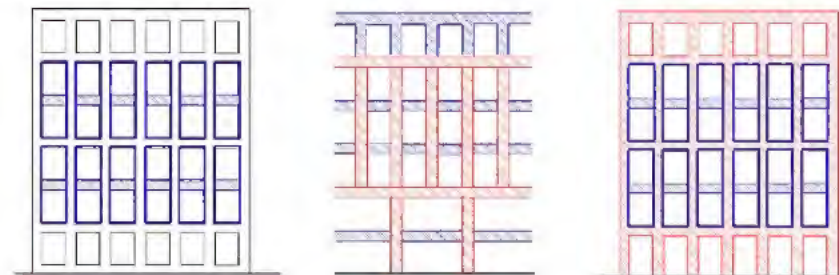

Grouping of windows to reduce perceived height of building



4.2.6 Climate Change & Sustainability

Town centre dwellings should be of the highest standards of environmental sustainability, in construction and operation. This includes mitigating their impact on climate change and the local environment, and also adapting to a future with more frequent and more extreme weather events.

Further guidance is set out in Spelthorne's *Climate Change Supplementary Planning Document (SPD)*.

DESIGN AIMS

Climate Change & Sustainability in Town Centre Neighbourhoods will be ensured through:

- Layout and orientation to minimise energy needs by orienting for solar gain and passive ventilation
- Absorption and slowing of surface water runoff by the use of Sustainable Drainage Systems (SuDS) and achieving a high Urban Greening Factor (UGF)
- Demonstrating no impact to groundwater flows through an appropriate engineering approach



The Climate Emergency will particularly affect Spelthorne and high standards of sustainability are expected.

4.2.6.1 MITIGATION: REDUCING ENERGY USE

Building energy use is a significant contributor to carbon emissions.

New buildings **must**:

- Be heated by electricity, and not include gas boilers or other carbon-emitting heat sources
- Achieve a 31% reduction on the Dwelling Emission Rate (DER) against the Target Emission Rate (TER) based on the 2013 Edition of the Building Regulations (Part L), as per [Local Plan](#) policy PSI.
- Orientate buildings as much as possible within +/- 30° of a south-facing aspect to maximise solar gain and passive heating
- Include a form of shading on windows, ideally external, and ensure windows can be opened
- Target a window coverage for residential dwellings as set out on the right

New developments **should**:

- Include on-site photovoltaic (PV) energy generation where possible
- Use low-temperature heat networks powered by zero-carbon heat sources such as Air Source Heat Pumps or Ground Source Heat Pumps
- Use heat sources within or adjacent to the development such as supermarket fridges to augment heat network sources
- Locate Air Source Heat Pumps away from areas where the noise could cause nuisance to other users. When located on roofs, they should be enclosed within the roof design.

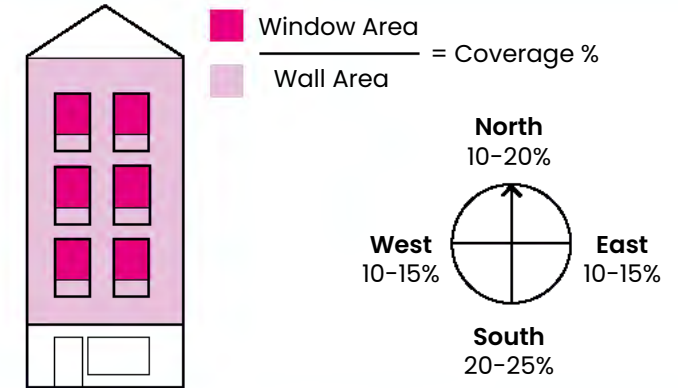

Flush photovoltaic panels incorporated into a roof



Energy Centre co-located with supermarket fridges and designed as marker building in street

4.2.6.2 MITIGATION: REDUCING EMBODIED CARBON

Embodied carbon is the emissions generated by the construction of buildings.

New development **should**:

- Prioritise the re-use of existing buildings and parts of buildings, such as foundations, frames and other carbon-intensive components
- Use locally-sourced recycled materials
- Minimise the use of high-carbon materials such as aluminium, steel, glass and concrete
- Maximise the use of low-carbon and reusable materials such as brick, cross-laminated and soft timber



For more detailed technical guidance on reduction of embodied carbon, consult the LETI Climate Emergency Design Guide

4.2.6.3 ADAPTATION: PREPARING FOR A CHANGING CLIMATE

Increased frequency of extreme weather events will mean:

- More intense storm events, with associated surface water runoff management requirements
- More intense heat events, which will particularly affect built-up areas

An increase in permeable surfaces, tree cover and planting can make a substantial contribution to mitigating these effects.

New development **must**:

- Achieve an Urban Greening Factor of at least 0.4, calculated using Natural England's Green Infrastructure Framework standards, through the use of green roofs and walls, planting and permeable surfacing, and urban sustainable drainage system features such as swales and rain gardens
- Provide an increase in tree canopy cover within the public realm when compared to the existing situation
- Include a safe pedestrian evacuation route from all circulation cores to a dry gathering area in the event of fluvial flood events
- Demonstrate no harm on groundwater flows from foundations or underground levels through an evidenced engineering solution

Low Urban Greening Factor

Mostly impermeable surfaces

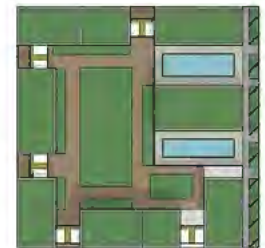
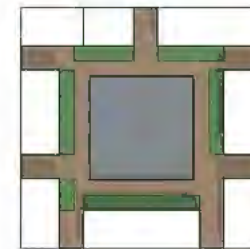
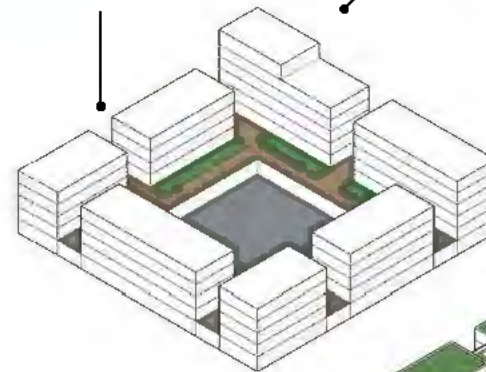

High Urban Greening Factor

Green roofs / Green walls
Street trees, swales and planting
Rain gardens and water on site
Permeable paving
Shared, drained gardens on internal podiums

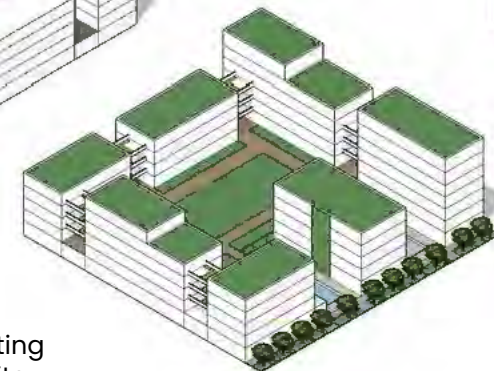

4.3 Inner Suburban

OVERVIEW

The Inner Suburban areas of Spelthorne were developed predominantly pre-WWI and in the early inter-war period. They have comparatively high densities compared to the rest of the borough, and are closely related to their nearby town centre.

These areas have a distinctive and replicable urban form, with tight gridded streets, mostly semi-detached homes on relatively narrow plots, and a variety of architecture along streets.



Intensification in Inner Suburban areas is supported but it must be done carefully, respecting the context.

AREAS OF CHANGE

There are no areas of significant planned change in the Inner Suburban area type. Development is expected to be small-scale, incremental change governed by the codes for the Development Types above.

DESIGN AIMS

Development in Inner Suburban areas will:

- Respect the existing street grid
- Reduce the visual and functional impact of car parking on the public realm
- Prioritise the walking and cycling potential of these areas
- Retain the rhythm and key dimensional characteristics of streets and buildings
- Ensure new homes can be delivered without compromising the existing character of the area

LOCATIONS

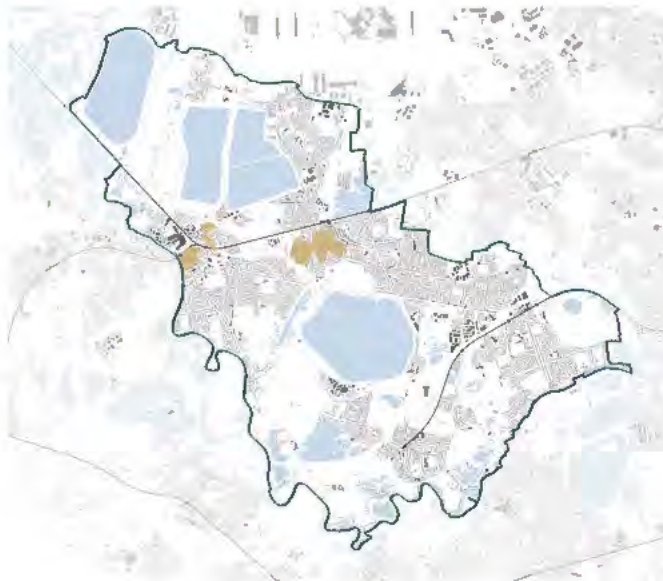

WHAT CODE SHOULD I USE?

The design requirements you need to apply will depend on the type of development you are proposing.



New homes or apartments on existing streets

See 4.3.1



Key requirements for **Residential Extensions** are coded, with further guidance contained in Appendix C.

See 4.3.2

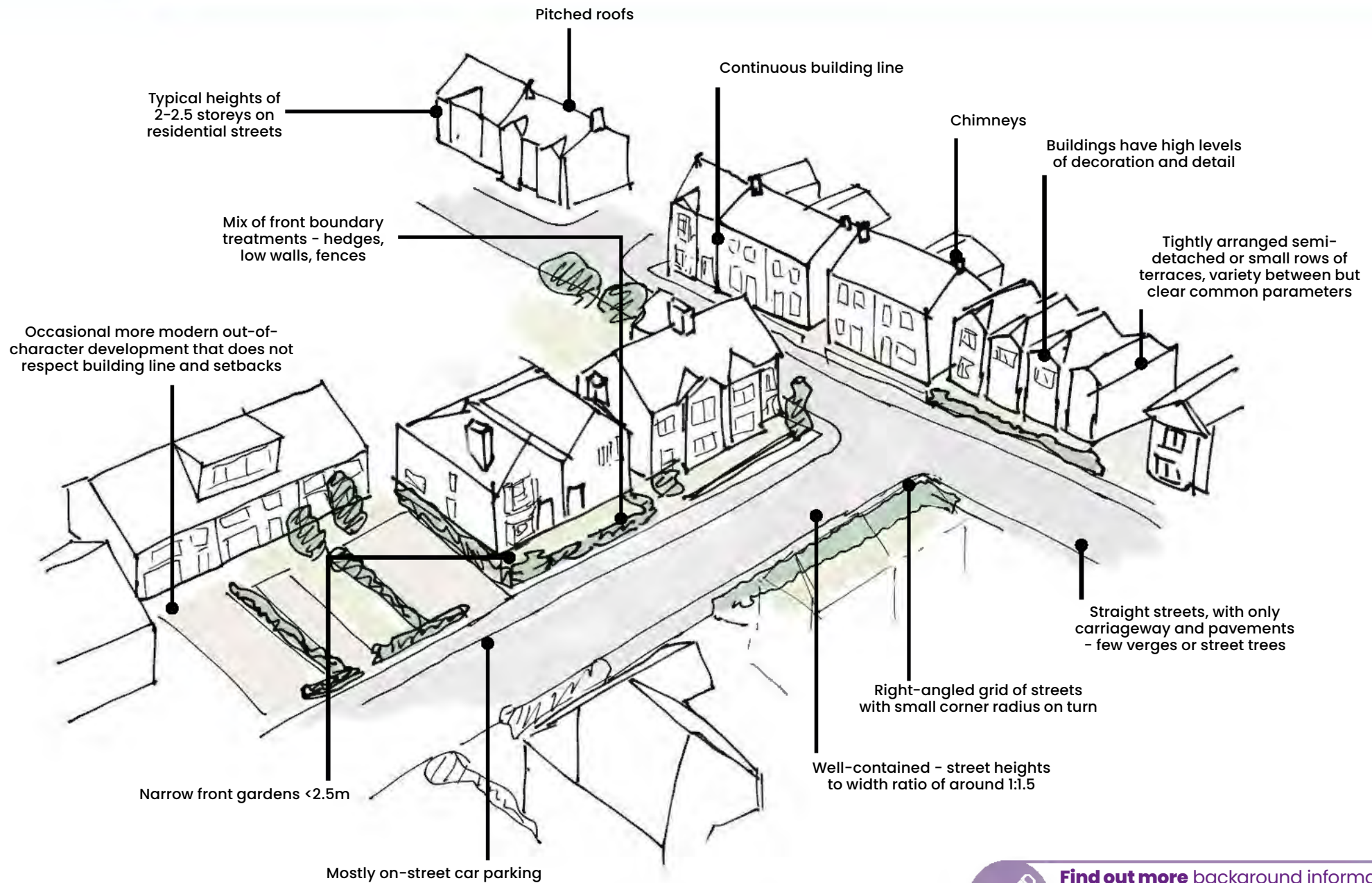

Existing characteristics of inner suburban areas



Find out more background information about the borough in Appendix A 'Understanding Spelthorne Today'.

4.3.1 New Homes or Apartments on Existing Streets

New apartments within existing Inner Suburban residential streets are a common form of development in Spelthorne. When designed well they can complement the existing street scene while delivering high quality new homes in locations close to High Streets and other facilities.

DESIGN AIMS

All Inner Suburban apartment development on existing streets **will**:

- Comply with Nationally Described Space Standards
- Address the needs of different design zones for street frontage, access, servicing and gardens
- Respect the existing street scene by observing the key design parameters, including:
 - the existing building line, rhythm of windows and separation distances, and the existing visual grain of the street
 - car parking placed to the rear of the built form, with vehicle access not dominating the frontage
 - adding any additional height sensitively
- Use materials and articulation to provide richness to the street scene

4.3.1.1 LAYOUT PRINCIPLES

New development on existing streets in Inner Suburban Area Types **should** follow the overall layout principles set out below. Coding requirements for different areas are set out on the following pages.

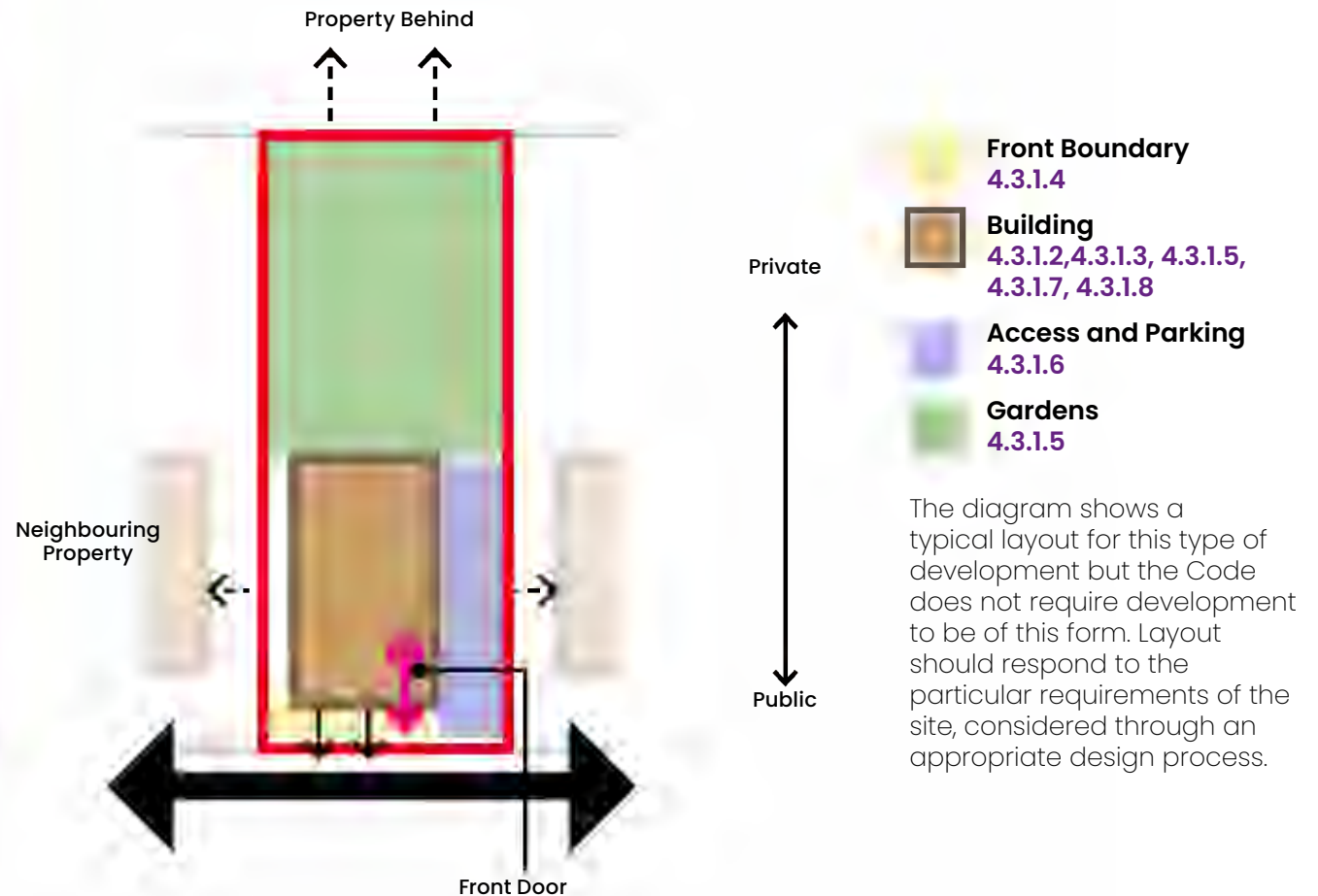



Building Heights typically up to height of highest adjacent building



Reflect existing street rhythm of gaps and built form



Regular building line along a street



Building lines for corner plots



Front boundary treatments in Inner Suburban areas are typically small front gardens with formal edges, such as railings, low walls or fences. Planting can be used to enhance the street scene and soften built form.



4.3.1.2 BUILT FORM PARAMETERS

New development on existing streets **must** observe the following key built form parameters:

- Roofline not above height of highest immediately neighbouring building
- **Plot coverage** that is broadly within the range of the existing area, typically 30-50%
- Match neighbouring building line on streets with regular building line
- Sites on street corners to match the building line of both adjoining streets and provide passive surveillance to both aspects
- Reflect the existing street rhythm of gaps and built form



4.3.1.3 ROOF FORM

New development on existing streets **must**:

- Have pitched roof forms, reflective of surrounding prevailing form, e.g. gable ends or street-facing pitch
- Avoid flat roof forms facing streets on main roofs
- Ensure dormers are set in a minimum of 1m from the roof edge, down 0.5m from the ridge and up 1m from the eaves, and not be dominant and out of proportion
- Flat-roofed dormers facing the street may be acceptable if the overall architectural design language of the development is **contemporary**, otherwise they must incorporate a roof which is compatible with the main roof



4.3.1.4 FRONT BOUNDARY TREATMENT

New development on existing streets **must** have:

- A defined front boundary that separates public realm from private space
- A clear pedestrian path to the front door
- A boundary treatment such as a low wall or railings, making reference to prevailing styles on the street
- A front door that faces the street
- Sheltered, defensible threshold space at the front door of at least 0.5m x 1m
- An accessible covered space to store waste and recycling
- Accessibility to users of all abilities with a variety of mobility needs

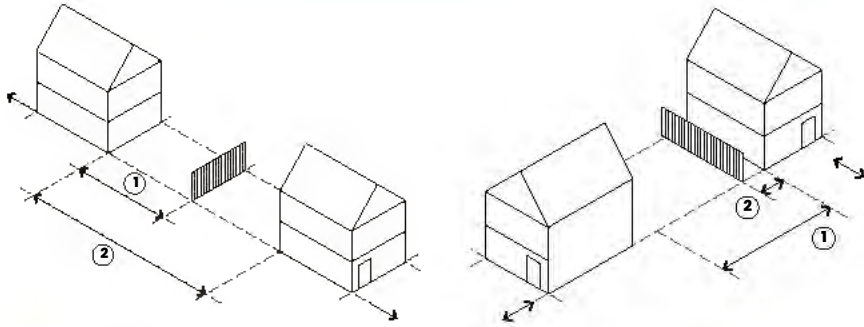

Maintain appropriate distances to existing properties

Left: Back to Back 21m (30m for 3 storey) (distance 2 on left diagram)

Right: Back to Flank 13.5m (21m for 3 storey) (distance 1 on right diagram)

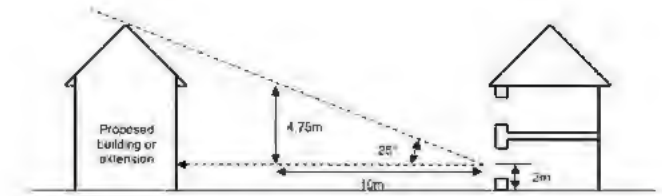

Ensure a 25° vertical line of sight to neighbouring properties to ensure daylight

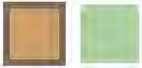

4.3.1.5 DAYLIGHT, PRIVACY AND OVERLOOKING

New development on existing streets **must**:

- Have a minimum back to back distance to properties at the rear of 21m (30m for 3 storey buildings)
- Ensure built form of two storeys or above is clear of a 45° line drawn from the centre of a habitable room in neighbouring properties, both horizontally and vertically
- Ensure a 25° vertical line of sight to neighbouring properties to ensure daylight
- Ensure a minimum back to flank distance 13.5m (21m for 3 storeys)
- Ensure a minimum boundary set-in distance 1m (2m for 3 storeys), or more to suit the context and prevailing street scene



4.3.1.6 ACCESS, CYCLE AND VEHICLE PARKING

New development on existing streets **must** have:

- Secure cycle parking provision, e.g. for apartments within a circulation core on ground floor
- If vehicle parking is provided, one of side, rear (shared) or integrated car parking to be used
- Brick paving or permeable gravel for car parking
- Planting and permeable surfaces within shared car parking areas (for apartments)
- Pedestrian access to rear gardens



4.3.1.7 APARTMENT DEVELOPMENT

All new apartment development on existing streets **must** ensure:

- Dual aspect apartments are maximised
- Single aspect apartments are no deeper than 6m from an external window
- There are no single aspect apartments on north-facing aspects
- Balconies face the street and rear, avoiding balconies facing towards adjacent properties to sides
- That recessed or partially projecting balconies are used

Where no other private outdoor space is provided, balconies **must**:

- Have a minimum depth of 1500mm
- Have a minimum of 5m² of private outdoor space for all 2 person dwellings and an extra 1m² provided for each additional occupant.
- Have level access from a habitable room, ideally a living room or living area



4.3.1.8 DETAIL, RICHNESS AND MATERIALITY

New buildings on existing streets **should** demonstrate how they have incorporated common features seen in Inner Suburban areas into their detailed design to enhance richness and variety in the street scene.



Roof line features



Bay windows and projections



Roof dormers



Gable ends



Changes in brickwork

To enhance the richness of the street scene, new buildings on existing streets **could** incorporate features such as sheltered seating with a boundary to the street, projecting bay windows (both traditional and contemporary in form), and integrated bin and cycle storage as part of the front garden.



Sheltered seating



New development on existing streets **must**:

- Use a single material for the elevation or;
- Have one clear change in materials between the ground floor and upper floors
- Use materials of high quality and long life, ideally with visible texture such as brick



Projecting windows



Integrated bin and cycle storage

4.3.2 Residential Extensions



OVERVIEW

The key design considerations for residential extensions on existing plots in Inner Suburban areas are set out on this page.

All new residential extensions **must** comply with these requirements.

This section sets out an overview of the key dimensional requirements for residential extensions. More detailed guidance on design for this type of development is contained in Appendix C, drawn from the previously adopted *“Design of Residential Extensions and New Residential Development Supplementary Planning Document (SPD)” (April 2011)*.

4.3.2.1 CONTEXT & CHARACTER

Designs **should** be mindful of key dimensions of the wider context that will ensure an extension fits within and complements that character of the area. These include:

- Set-in distance: the distance from plot edge to the flank side of the building. It defines the characteristic width between properties along a street. Care should be taken to reflect the existing street scene.

- Set-back distance and prevailing building line
- Minimum requirements for key dimensions are set out on these pages.

Key characteristics to observe that extensions **should** respond to in architectural design include:

- Prevailing materials of the area
- Prevailing roof forms and features
- Rhythm of windows and location of front doors on façades

4.3.2.2 PRIVACY & OUTLOOK

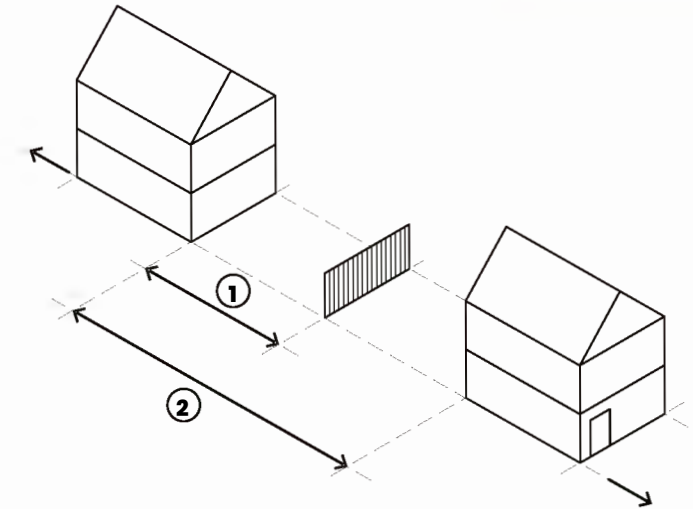

Minimum dimensions **must** be at least:

1. Garden length 10.5m (15m for 3 storeys)
2. Back to back distance 21m (30m for 3 storeys)

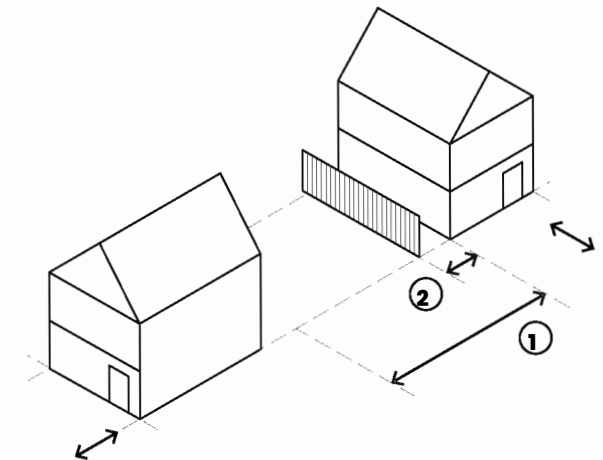

1. Back to flank distance 13.5m (21m for 3 storeys)
2. Boundary set-in distance 1m (2m for 3 storeys), or more to suit the context



Find out more background information about the borough in Appendix A ‘Understanding Spelthorne Today’.

4.3.2.3 DAYLIGHT

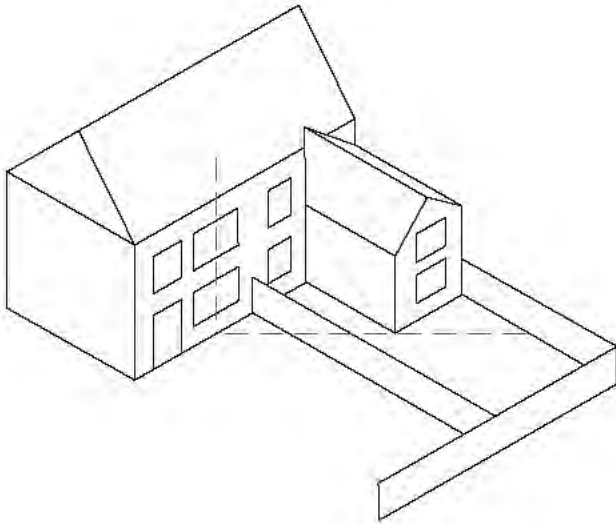

- Two-storey extensions **must** be clear of a 45° line drawn from the centre of a habitable room in neighbouring properties, both horizontally and vertically

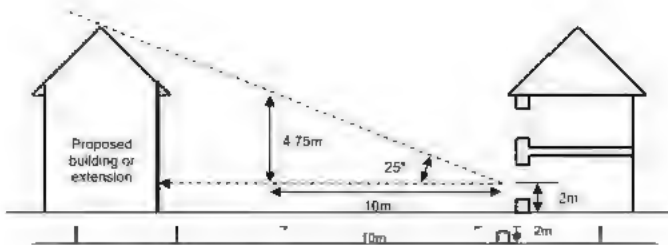

- Development **must** maintain a 25° vertical line of sight to neighbouring properties to ensure daylight

4.3.2.4 SIDE EXTENSIONS

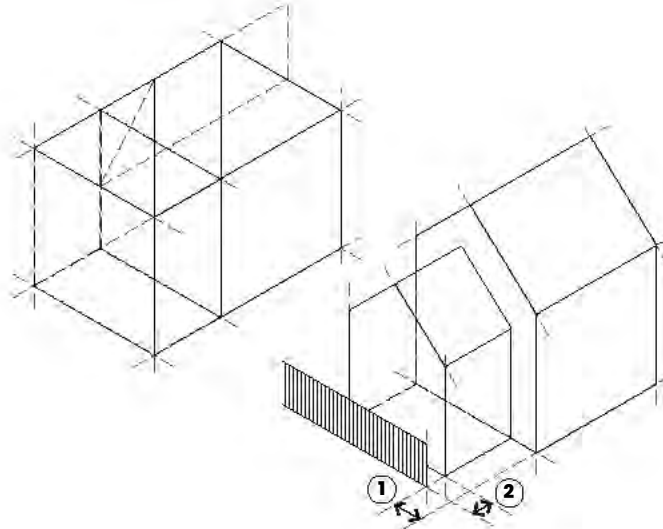

- Single storey side extensions **must** be set back from the main building line (1) by at least 300mm, and set in from the plot boundary (2) by at least 250mm
- Multi-storey side extensions **must** be set in from the plot boundary (2) by at least 1m (2m for 3 storey development), or more to suit the context
- Subordinate multi-storey side extensions **must** be set back from the main building line (1) by a minimum of 1m
- Inline side extensions may be acceptable in certain circumstances, particularly detached houses. Further guidance can be found in Appendix C.

4.3.2.5 DORMERS

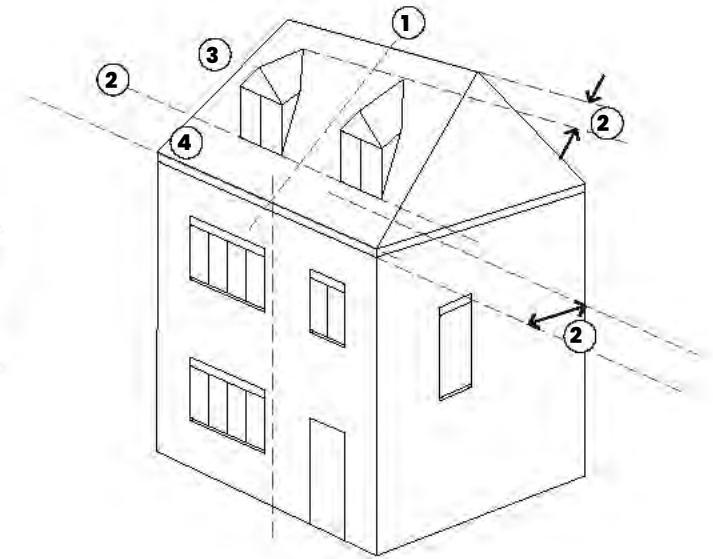

Dormers **must**:

- Be located centrally or symmetrically on a roof
- Be set in a minimum of 1m from the roof edge, down 0.5m from the ridge and up 1m from the eaves
- Incorporate a roof which is compatible with the main roof
- Not be dominant and out of proportion

Suburban

OVERVIEW

Spelthorne's post-war suburban areas, typically laid out in the period 1945-1970, are characterised by lower-density housing on a street grid. While semi-detached houses are most common; terraced and detached homes as well as bungalows are found across the borough.

Many of Spelthorne's suburban locations benefit from proximity to green spaces and larger plot sizes. There is often less distinctive identity between the areas. Because they tend to be further from their core town centres, they often host small local parades of shops at key nodes.

At the edge of existing built-up areas or within larger infill sites, new residential neighbourhoods are anticipated of between 15-200 homes at a range of potential densities, with a mix of homes or apartments.



New residential neighbourhoods must provide well-designed homes that are integrated into their surroundings.

AREAS OF CHANGE

Development in existing suburbs is expected to be small-scale, incremental change governed by the codes for the relevant Development Types.

Development of New Residential Neighbourhoods will be a change in character and is governed by the Coding set out in this chapter.

DESIGN AIMS

Development in Suburban Areas will

- Integrate new development into existing places positively
- Create new residential neighbourhoods with green spaces and attractive streets
- Maximise opportunities for green infrastructure on street and frontages
- Prioritise walking and cycling potential
- Retain the rhythm and key dimensional characteristics of streets
- Take opportunities to sensitively intensify residential density without compromising the existing character of the area

LOCATIONS

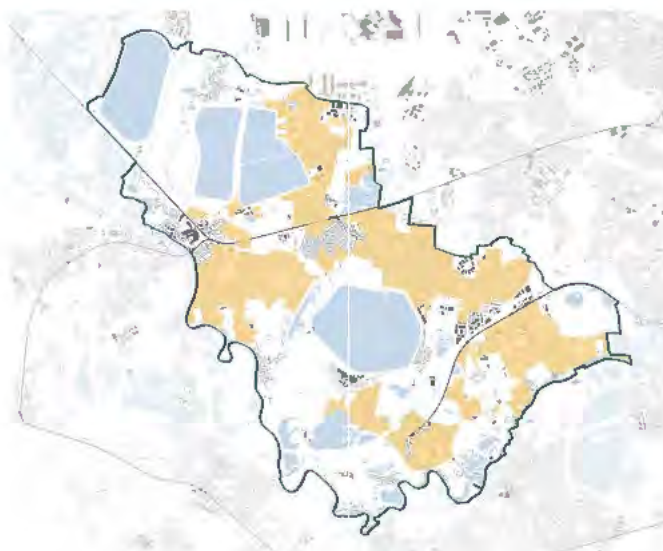

WHAT CODE SHOULD I USE?

The design requirements you need to apply will depend on the type of development you are proposing.

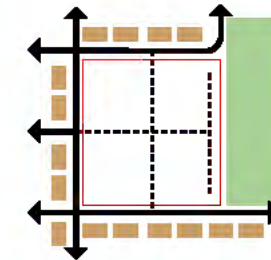

New Residential Neighbourhoods, either on the edge of the existing built up area or as larger sites within the existing built-up area.

See 4.4.1



New buildings on existing streets

See 4.4.2

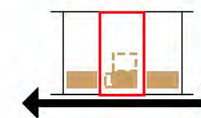

Key requirements for **Residential Extensions** are coded.

See 4.4.3

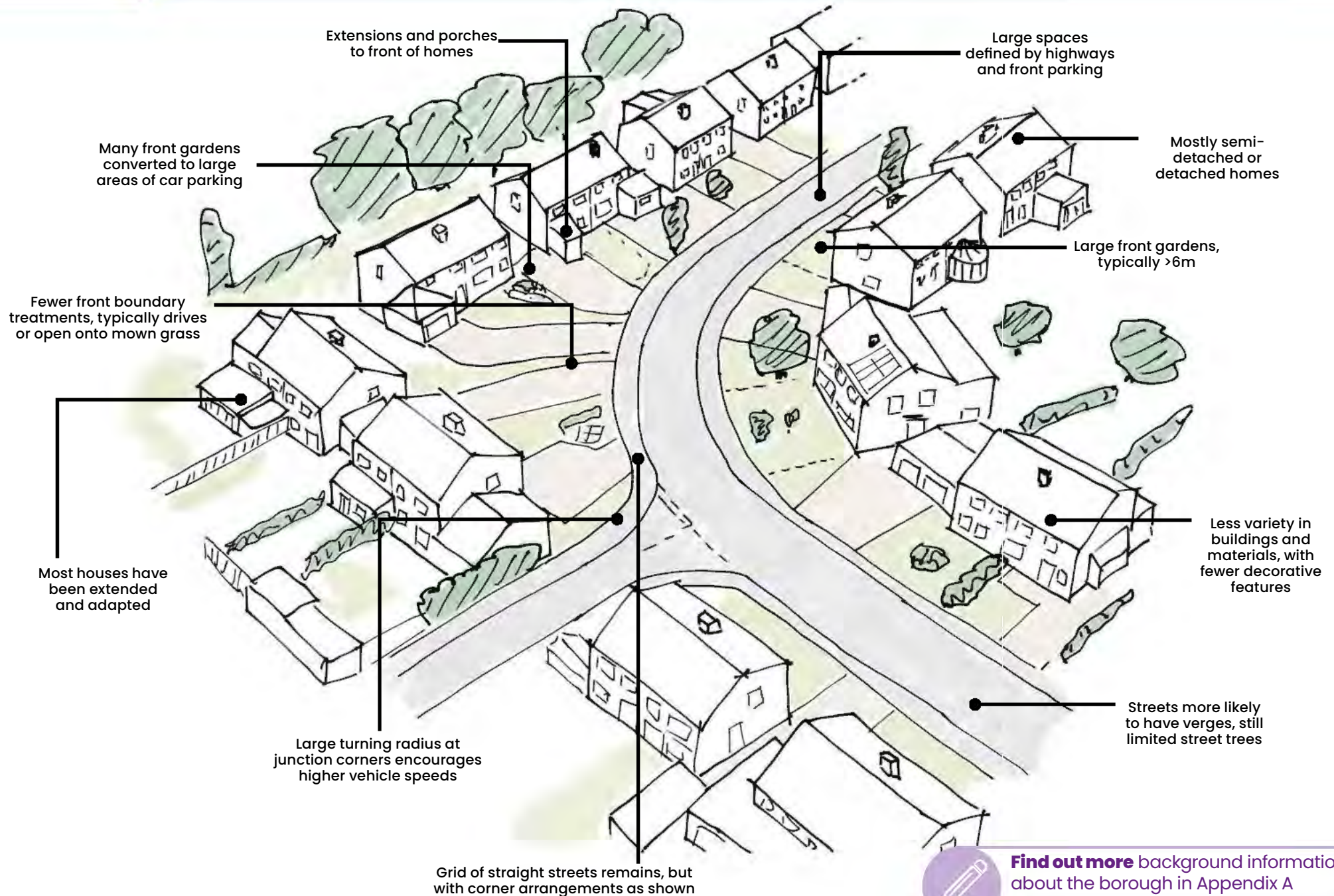

Existing characteristics of suburban areas



Find out more background information about the borough in Appendix A 'Understanding Spelthorne Today'.

4.4.1 New Residential Neighbourhoods

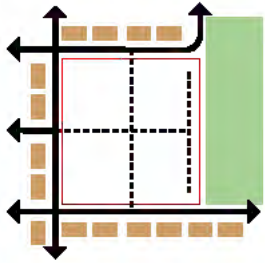

Coding for larger areas of residential development in, or on the edge of the existing suburban area, is set out in this section. This may include:

- Allocated small sites that have been released from the Green Belt as part of the [Local Plan](#).
- Other sites adjacent to existing built-up area
- Larger infill sites within existing built-up area

This coding is to be applied typically for developments of between around 15-200 homes.

New residential neighbourhood sites that are not allocated in the [Local Plan](#) **must** also comply with the requirements set out in this section.

DESIGN AIMS

All new residential neighbourhoods will:

- Be inspired by and reflective of the place
- Integrate with and complement their surrounding areas through the consideration of edges and looking beyond the site boundary
- Have legible, connected streets that prioritise walking and cycling, and with car parking integrated so that cars do not dominate the street scene
- Have public green open spaces that are safe, well-managed, ecologically rich and complementary in scale and design to the surrounding built form

4.4.1.1 ENSURING DISTINCTIVENESS

New residential neighbourhoods will be clearly inspired and influenced by their surroundings.

New residential neighbourhoods **should** demonstrate as part of the [design process](#) how they have observed, studied and responded to:

- Typical local block structure, dimensions and grain of built form
- Scale, character, use and built form enclosure of local open spaces
- Typical materials and architectural features such as roof forms and elevational treatments used in the local area
- Distinctive local landscape features (e.g. Spelthorne's distinctive cedar trees)
- Historic uses and users of the site and context
- Absences from the local area that could enhance it (e.g. a need for more play provision, different approaches to housing provision, open space, food production or access to nature)



Find out more background information about the borough in Appendix A 'Understanding Spelthorne Today'.



Safe, well-managed car parking approaches are an important part of what makes places successful.

4.4.1.2 EDGES

On sites extending the existing built up area, how edges are considered will make a significant difference to how the scheme integrates with its surroundings. Addressing edge conditions successfully can:

- Make new developments healthier by enabling new walking and cycling connections
- Integrate the scheme visually and physically so that in future it becomes a coherent part of the surroundings
- Reduce any impacts on surrounding buildings
- Minimise ongoing management issues
- Maximise site capacity by using land at the edges productively

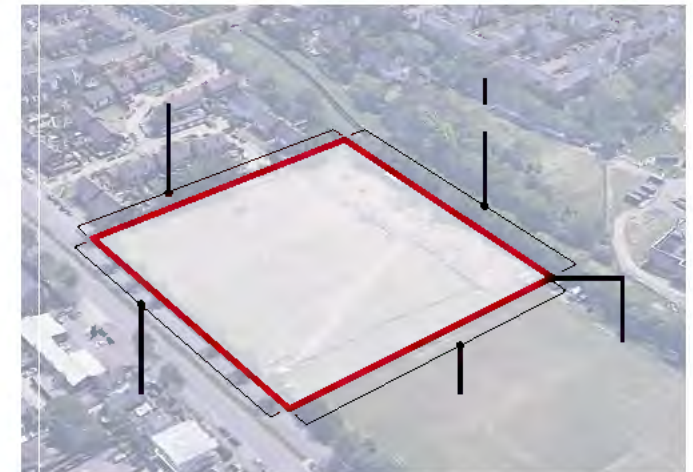

Example green field development site west of Sunbury Cross with edges highlighted

Edges: Green And Blue

4.4.1.2a Trees, Woodland and Hedgerows

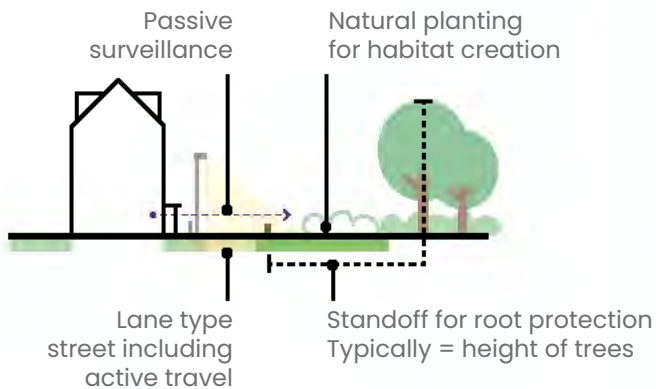
Development **must:**

- Retain and protect existing green infrastructure already on site
- Limit removal of existing green infrastructure to enable safe, overlooked access points
- Retain hedgerows and trees within public space, accessible for management
- Enhance existing hedgerows with additional diverse native planting
- Not place existing hedgerows or tree belts at the back of new properties. This will hinder access for future maintenance.

4.4.1.2b Open Spaces

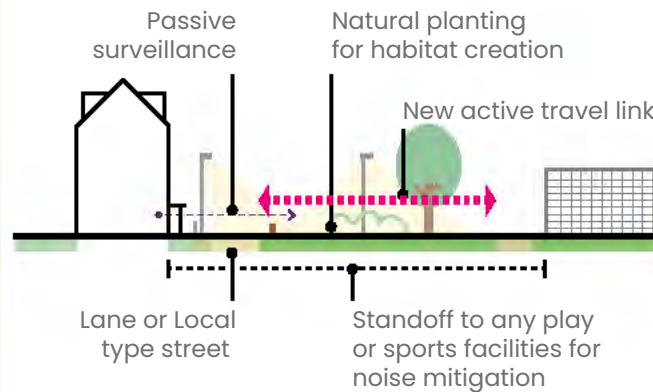
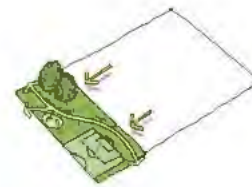
Development **must:**

- Front new development to face towards existing open spaces
- Provide views towards existing open spaces from key nodes or spaces
- Connect open spaces to new development through active travel links, and provide new active travel links along the edge of existing open spaces with enough lighting to ensure safe use all year round
- Increase biodiversity by providing planted edges such as wildflower areas.

4.4.1.2c Watercourses and Water Bodies

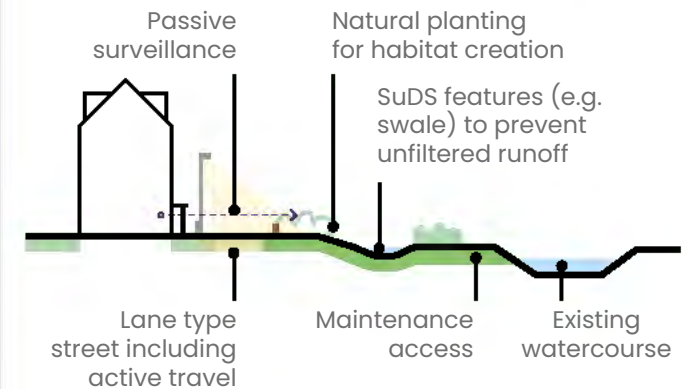
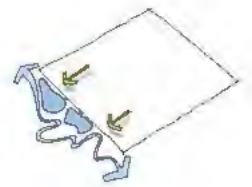
Development **must:**

- Provide new active travel links along the edge of existing watercourses with enough lighting to ensure safe use all year round
- Front development towards watercourses or drainage features so they are accessible for management
- Ensure surface water runoff is filtered by at least one stage of SuDS before entering the watercourse
- Increase biodiversity by providing planted edges such as wildflower areas, or integrated with SuDS features

Edges: Transport And Movement

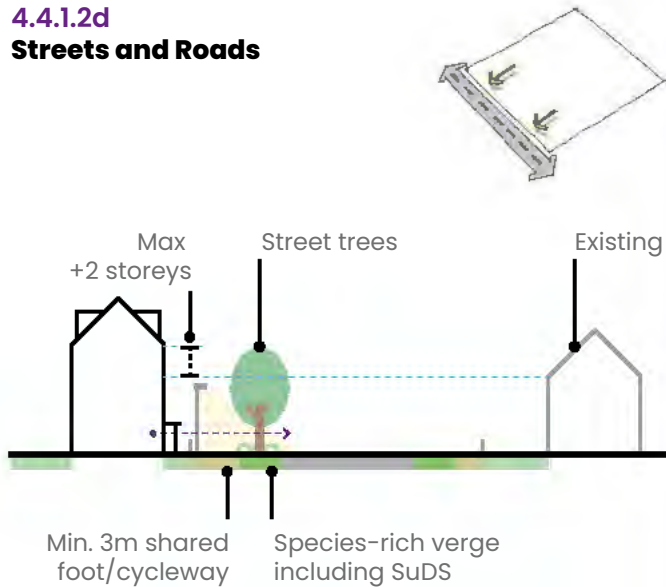
4.4.1.2d
Streets and RoadsDevelopment **must:**

- Front new development towards existing streets and roads
- Set new development back in a way that respects the existing characteristic dimensions of the street or road
- Include street trees and planting along the street edge, and provide linear ecological habitats such as wildflower verges
- Improve pedestrian and cycling provision on existing roads adjacent to the site, potentially providing a new off-road connection through the site

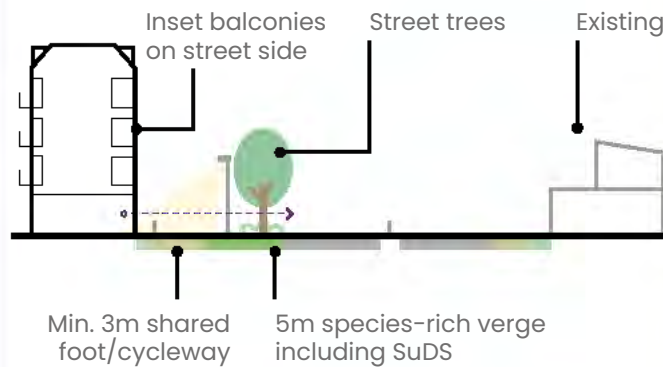
4.4.1.2e
Dual CarriagewaysDual carriageways that are also urban roads
(e.g. A308 Staines Road West in Sunbury Cross)

Dual carriageways designed as bypasses (e.g. M3 and Upper Halliford bypass)

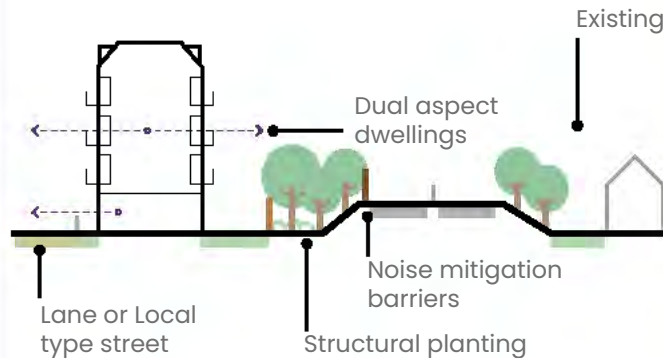
Development **must:**

- Ensure living spaces adjacent to roads have sufficient sound insulation

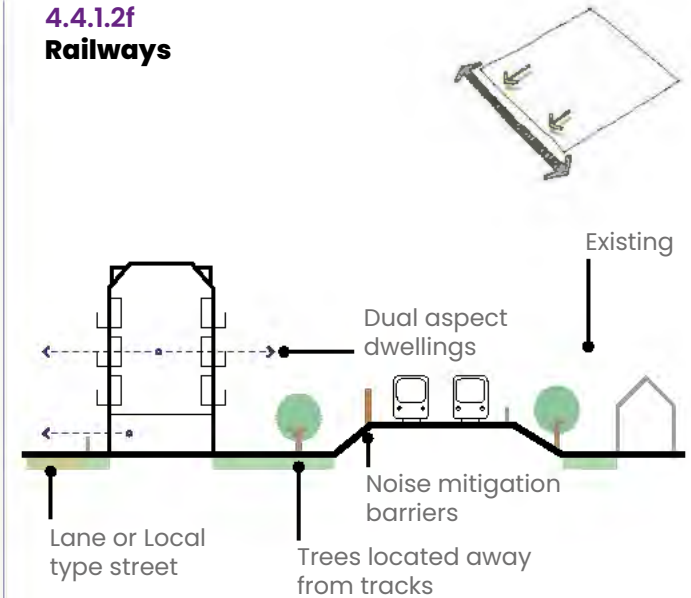
4.4.1.2f
RailwaysDevelopment **must:**

- Concentrate higher density development close to railway stations
- Provide lighting and overlooking towards any pedestrian footbridges or underpasses that enter or are adjacent to the site
- Place new tree planting at a sufficient distance from the railway tracks so as to not create autumnal leaf-fall impacts
- Reduce access between development and the railway line, but where this is not possible or appropriate, ensure good lighting and passive surveillance to prevent anti-social behaviour
- Provide anti-trespass fencing by either providing new or upgrading existing

Edges: Existing Built Form

4.4.1.2g Residential (Backing onto and Facing onto)



Existing Residential Backing onto the Site

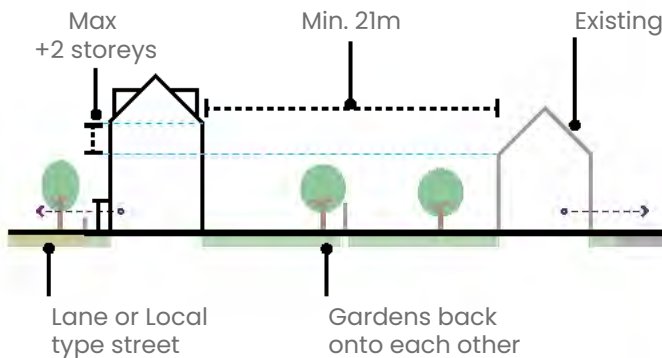

Existing Residential Facing the Site across an Existing Street

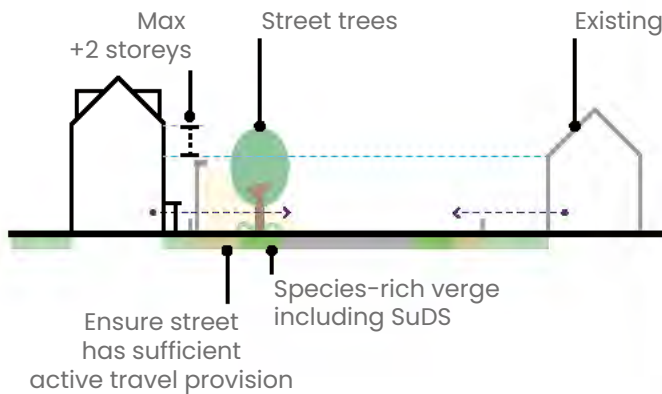

4.4.1.2h Local Facilities

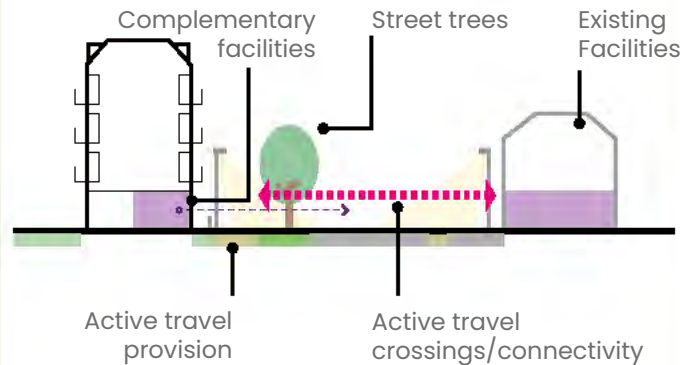
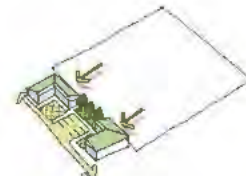

Development **must**:

- Make walkable connections to nearby local facilities
- Co-locate any new facilities or uses adjacent to existing facilities
- Concentrate development density close to relevant local facilities, e.g. local shopping
- Prevent overspill parking near local facilities through the design of streets or enforced parking restrictions

4.4.1.2i Industry and Commercial Uses

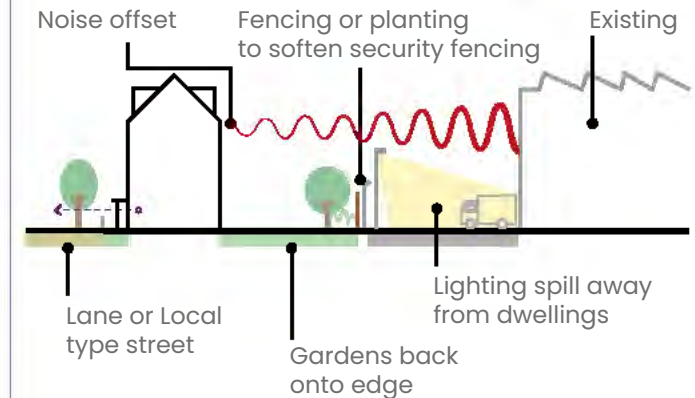
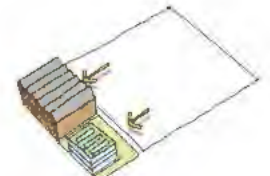

Development **must**:

- Set new homes a sufficient distance from noise-emitting uses to ensure a maximum outdoor residential noise level of 55dB during the day and 45dB at night
- Provide screen planting and other measures to prevent industrial light sources from spilling into homes

4.4.1.3 MOVEMENT: LEGIBLE, CONNECTED STREETS

4.4.1.3a Street Layout Approach



New streets will be designed in a way that provides a sense of place as well as connectivity and accessibility to surrounding areas.

Streets will be designed around people, not vehicles. They should bring communities together and enhance their quality of life. Streets will be designed with flexibility and sustainability in mind, so that they will last for future generations.

Street types are determined by the importance of their place and movement functions, not their desired capacity or design speed. The decision on street typology is a collective decision with designers, planners, transport engineers and the local community. It must not be the sole decision of transport engineers.

Streets should be accessible to all abilities and ages through the use of drop kerbs, tactile paving, regular seating and clear sightlines and sufficient lighting for visibility and safety.

Street layout and design **must** be in compliance with the Surrey Healthy Streets Design Code.

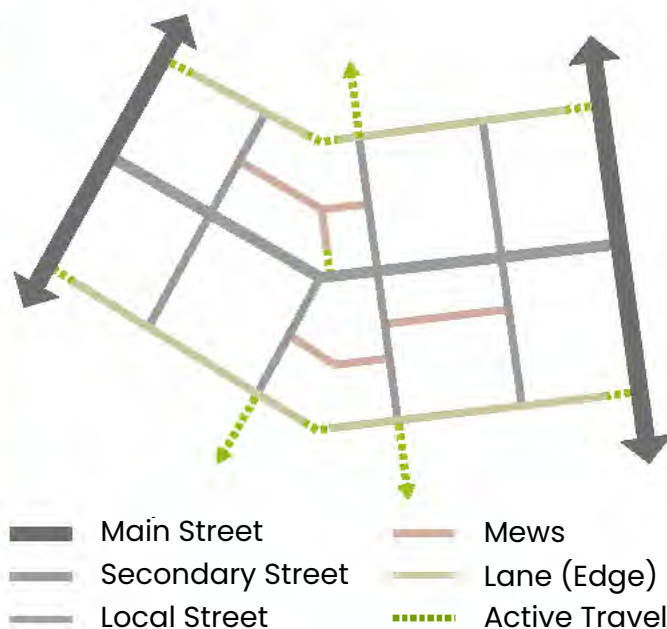

Street layouts **must**:

- Have a clear street hierarchy drawing on the types set out in this Code
- Create blocks of between 60-100m, with crossroads arrangements supported to align blocks
- Use filtered permeability, with active travel prioritised and having a continuous grid of routes, and private vehicles required to take more circuitous routes to access homes

4.4.1.3b Main Streets



Main streets **must**:

1. Have a carriageway between 5.5m and 6.5m
2. Have verges at least 2.5m wide, to incorporate street trees, planting and bus stop laybys
3. Have a footway on each side at least 2m wide, and a cycleway on each side at least 2m wide
4. Have continuous footways across junctions with streets lower in the hierarchy
5. Have a width:height enclosure ratio of between 2:1 (more urban) and 4:1 (minimum)

Where development fronts onto existing main streets, it **must**:

6. Safeguard sufficient land for future walking and cycling improvements
7. Align active travel links with existing or planned crossings

4.4.1.3c Secondary Streets



Secondary streets **must:**

1. Have a carriageway of between 4.8m and 6.0m
2. Have verges of at least 2.5m wide, to incorporate street trees, planting and occasional on-street parking bays
3. Have a footway of at least 2m wide, and a shared footway/cycleway of at least 3m wide
4. Include occasional build-outs for pedestrian crossings to slow vehicles
5. Have continuous footways across junctions with streets lower in the hierarchy
6. Have a width:height enclosure ratio of between 1:1 (ideal) and 3:1 (minimum)

4.4.1.3d Local or Residential Streets

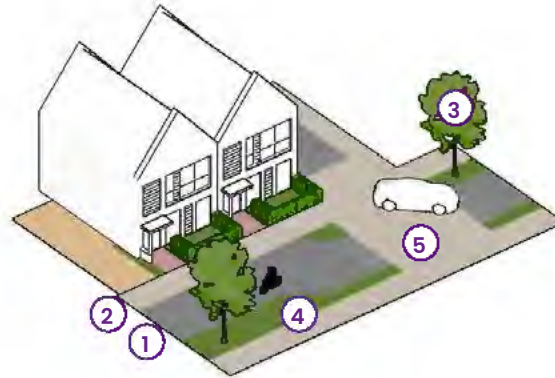

Local or Residential streets **must:**

1. Have a carriageway of between 3.5m and 4.8m, with local widening to allow passing of vehicles
2. Have footways at least 2m wide
3. Be lined with street trees
4. Include occasional planting, rain garden and change in direction of the carriageway to slow vehicles
5. Use raised tables with brick paving or other surface changes at junctions with other Local or Mews Streets
6. Have a width:height enclosure ratio of between 1:1 (ideal) and 3:1 (minimum)

4.4.1.3e Mews and Lanes



Mews and Lanes **must:**

1. Be a minimum of 6m wide
2. Be a shared surface for pedestrians and vehicles, of brick, paved or permeable paving construction
3. Include occasional planting, trees and features to slow vehicles
4. Include in-street drainage features such as rills and rain gardens
5. Have a width:height enclosure ratio of between 1:1 (ideal) and 2:1 (minimum)
6. Provide continuous active travel connectivity between edge lanes, with no gaps created between 'private drive' type arrangements

4.4.1.4 MOVEMENT: CAR PARKING



Developments must be designed around people not the car. When poorly-designed, car parking can have a significantly detrimental effect on the quality of a street and place.

The parking typologies set out on this page are supported in New Residential Neighbourhoods in Spelthorne, provided they are designed in compliance with the Design Requirements.

Vehicle parking **must:**

- Be provided at a quantity and with dimensions that comply with Surrey County Council's parking standards, including EV charging points
- Have at least 10% of parking spaces as disabled spaces, located within 50m of the relevant building entrance
- Provide at least 0.2 visitor spaces per dwelling in on-street or otherwise unallocated spaces

4.4.1.4a On-Plot Parking

On-plot parking **should** be used in lower-density areas of new residential neighbourhoods, typically of 35 dwellings per hectare or lower.

All dwellings with on-plot parking spaces **should** be equipped with an EV charging point.

Frontage parking **must:**

- Have planting at least every four spaces in a run
- Include trees to soften views along longer runs of parking
- Be differentiated in surface material from the carriageway, using permeable materials
- Retain footway or planted front garden area of least 1.5m behind the parking space

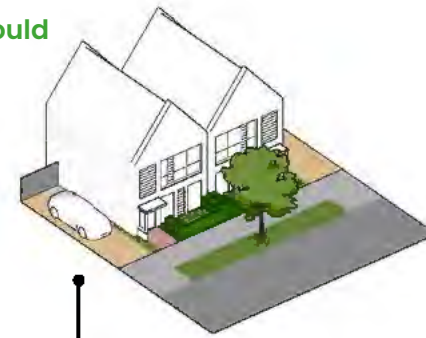
Side parking **must:**

- Be a minimum of 3.3m wide
- Maintain level footways and cycleways when accesses cross, using quadrant kerbs to provide a drop to the carriageway, as shown below
- Use permeable materials

Integral parking **must:**

- Be a minimum of 6.0 x 3.0m internally
- Have a garage opening of at least 2.7m wide
- Have a garage door no more than 50% of the building frontage width
- Ensure a ground floor window is provided in addition to the front door and garage door
- Use permeable materials

4.4.1.4b On-Street and Shared Parking

On-street parking and shared parking approaches **should** be used in higher-density areas of new residential neighbourhoods, typically between 40-75 dwellings per hectare.

All dwellings with on-street and shared parking spaces **should** be equipped with an EV charging point, as set out by Surrey County Council's "Recommended guidance for electric vehicle charging requirements".



On-street parking **must:**

- Be unallocated
- Have runs of no more than four spaces
- Leave no unused space to prevent nuisance parking
- Have squared-off kerb returns
- Be differentiated in surface material from the carriageway, using permeable materials
- Be contained within verge/planted areas at the edge of carriageways, with planting or street trees at the ends of runs



Parking squares **must:**

- Have planting at least every four spaces in a run
- Must not exceed 12 spaces
- Include trees within some planted areas
- Be overlooked from surrounding dwellings
- Be differentiated in surface material from the surrounding streets, using permeable materials



Rear parking courts **must:**

- Be overlooked from dwellings
- Be lit to provide security at all times. Lighting spread should be designed so as not to disturb neighbours. Motion-sensitive lighting is supported for its reduced energy use and impact on ecology
- Have planting or trees at least every five spaces in a run
- Use permeable materials
- Provide overlooked, safe access to apartment circulation cores via an overlooked route



Safe, well-managed car parking approaches are an important part of what makes places successful.

4.4.1.5 SAFE, ATTRACTIVE AND MULTIFUNCTIONAL OPEN SPACES



All development of New Residential Neighbourhoods in the Suburban area type **must** provide public open space at the levels, standards and accessibility specified in the latest Open Space Assessment, currently:

- Amenity Green Space: 0.6 hectares (ha) / 1000 people, within 480m of all homes
- Parks and Recreation Grounds: 0.8ha / 1000 people, within 400m of all homes
- Provision for Children and Teenagers: 0.1ha / 1000 people, within 400m of all homes
- Natural Green Space: 1.0ha / 1000 people for new development including amenity green space, within 500m of all homes
- Allotments: 0.25ha / 1000 people, within 800m of all homes

Additional Code requirements for two different types of open space are set in this section.

4.4.1.5a Meeting Points: Open Spaces Amongst Homes



Open spaces amongst homes **must**:

- Have high levels of enclosure from surrounding built form
- Have traffic calmed surrounding streets with a change in carriageway materials
- Be overlooked from surrounding homes
- Include sufficient lighting for safety
- Include cycle parking and seating
- Be accessible to and inclusive of all users

Open spaces amongst homes **could** include:

- Planting and habitat creation
- Traffic-free active travel links
- Rain garden and surface water management features
- Community garden and food production
- Small events space
- Children's play features

4.4.1.5b Getting Outdoors: Open Spaces on the Edge of the Built-up Area



Open spaces at the edge of built-up areas **must**:

- A. Be overlooked from surrounding homes
- B. Have a transition in character from managed to natural, with uses such as play areas closer to homes
- C. Include sufficient lighting for safety on any active travel routes that pass through the space
- D. Include features such as bollards that prevent vehicles from entering or parking on the space from surrounding streets
- E. Be accessible to and inclusive of all users

Open spaces at the edge of built-up areas **could** include:

1. Natural habitat creation
2. Surface water management features that also function as natural habitats
3. Traffic-free active travel links and connections to surrounding open spaces and other destinations
4. Childrens play areas
5. Seating along footpaths
6. A distinctive built form edge with views across the open space, with the potential for taller heights to address the space



Being connected to the outdoors and wider green networks is an important part of living in Spelthorne.

4.4.1.6 LANDSCAPE CHARACTER

New residential neighbourhoods will blend built form with planting, soft landscape and green infrastructure, to create a softer, less formal environment than town centres and inner suburbs. There will be proportionally more soft landscape than hard landscape.

4.4.1.6a Hard Landscape

Hard landscape features will typically be within streets, including footways, cycleways and carriageways. It will also include incidental hard landscape features and squares within open spaces or at key nodes within the street network.



Brick paving can provide a cohesive and traffic-calmed environment on smaller residential streets and key nodes or junctions



Resin-bound gravel can provide an attractive and practical surface for informal leisure paths through open spaces

Material selection in the public realm **must** be in compliance with the Surrey Healthy Streets Design Code.

4.4.1.6b Soft Landscape

Soft landscape features play an important part in the quality of the built environment.

In more formal areas, such as busier streets and areas with more hard landscape, a more ornamental palette is appropriate.



A mix of grasses and low-maintenance evergreen species



Evergreen shrub species planted within verges to prevent verge parking



Including mown amenity grass ensures open spaces can be flexible for different uses

Closer to the edge of the built-up area and larger open spaces, a more informal mix of native species, including trees and hedgerows, **should** be used, maximising habitat creation opportunities.



Wildflower planting within verges or larger areas of open space



'Play on the way' features within retained mature tree corridor

Species selection **should** be diverse, prioritising native and locally appropriate species to enhance resilience to climate change, support biodiversity, and reduce the risk of invasive species.

Management and maintenance **should** be minimised where possible for most areas, saving more maintenance-intensive species for small areas of high impact.

4.4.1.6c Street Trees

All streets **must** be tree-lined. In general trees will be integrated within verges and as part of the street green infrastructure, as set out under S-U3 and S-U4. Suitable approaches include:



Lines of trees within verges



Trees installed to aid traffic calming features



Trees installed to break up frontage parking or parking squares

Trees **must** have sufficient space to grow and thrive, following guidance set out by the Trees and Design Action Group (see reference in Chapter 6).

Using a variety of street tree species ensures resilience to climate change and invasive species.

4.4.1.6d Surface Water Drainage Features

All development **must** manage surface water through the use of Sustainable Drainage Systems (SuDS). Suitable design features include:



Source Control / Initial Absorption Features

- Street 'rain gardens'
- Planted verges and general soft landscape cover



Conveyancing Features

- Planted street swales
- Other overland flow features with minimal culverting or piping



Attenuation Features

- Surface attenuation basins, planted to create new habitats
- Attenuation ponds with permanent water

4.4.2 New Homes or Apartments on Existing Streets

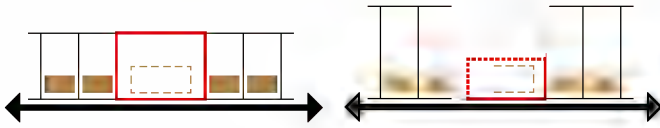

Development of new dwellings or apartments on plots on existing Suburban residential streets will be designed to complement the existing street scene and character of the area, while delivering high quality new homes throughout the borough.

In contrast to Inner Suburban locations, Suburban areas have more space between buildings and typically larger front garden areas, allowing more flexibility for the design of new development.

DESIGN AIMS

All Suburban development on existing streets will:

- Comply with Nationally Described Space Standards
- Address the needs of different design zones for street frontage, access, servicing and gardens
- Respect the existing street scene by observing the key design parameters, including:
 - the existing building line, rhythm of windows and separation distances
 - car parking not dominating the frontage
 - respecting heights and scale of streets
- Use materials and articulation to provide richness to the street scene

4.4.2.1 LAYOUT PRINCIPLES

New development on existing streets in Suburban Area Types **should** follow the overall layout principles set out below. Coding requirements for different areas are set out on the following pages.

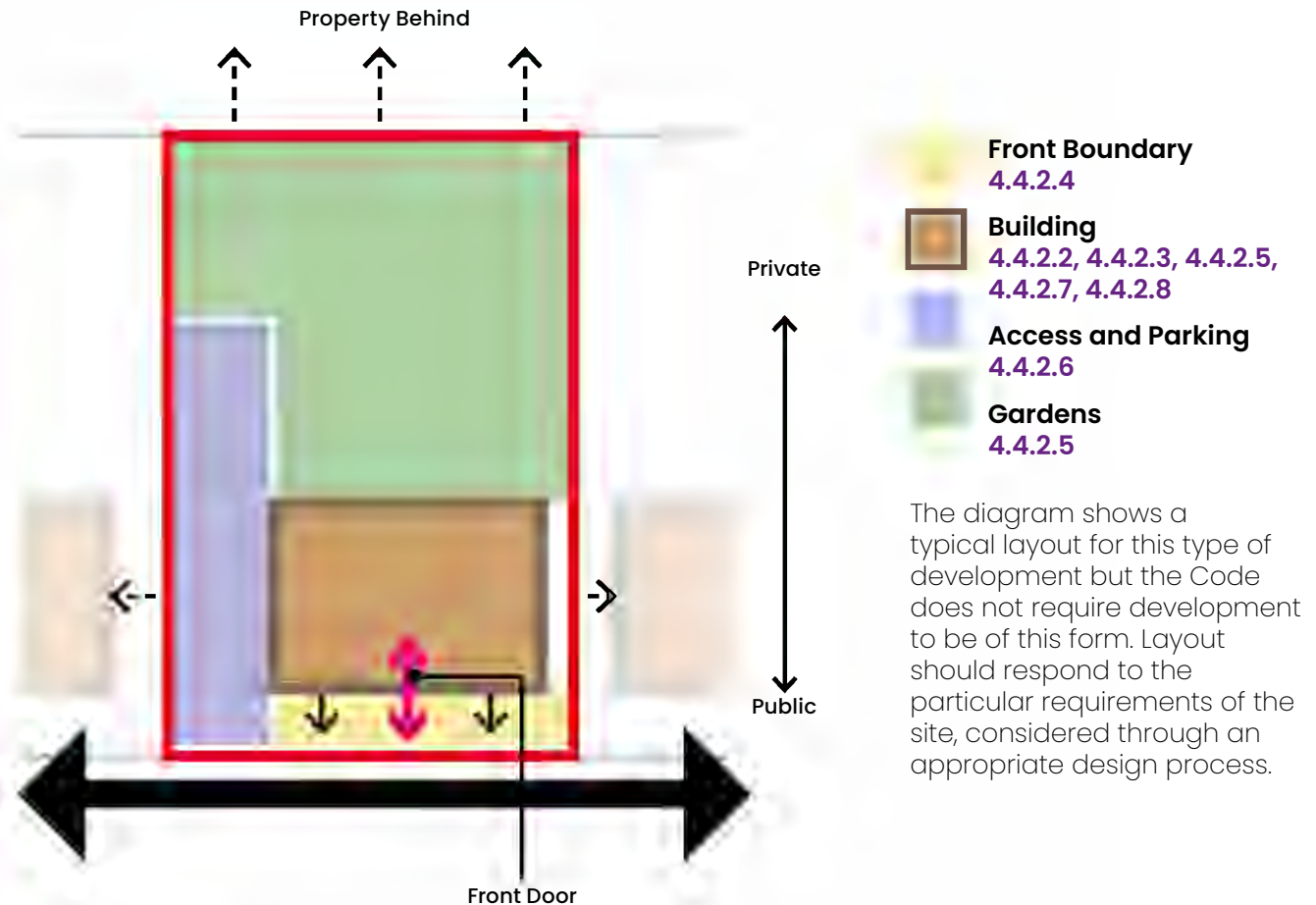

The diagram shows a typical layout for this type of development but the Code does not require development to be of this form. Layout should respond to the particular requirements of the site, considered through an appropriate design process.

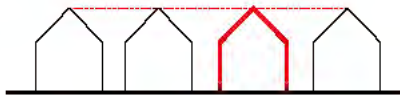

Building Heights typically up to height of highest adjacent building



Reflect existing street rhythm of gaps and built form

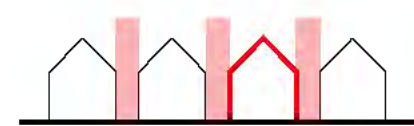

Regular building line along a street



Building lines for corner plots



Irregular building line establishes zone for new building front



Front boundary treatments in suburban areas typically include planting and landscape to soften the built form and parking arrangements



4.4.2.2 BUILT FORM PARAMETERS

New development on existing streets **must** observe the following key built form parameters:

- Roofline not above height of highest immediately neighbouring building
- **Plot coverage** that is broadly within the range of the existing area, typically 25-40%
- Match neighbouring building line on streets with regular building line
- Where building line is irregular, use neighbouring buildings to establish zone for building line
- Sites on street corners to match the building line of both adjoining streets and provide passive surveillance to both aspects
- Reflect the existing street rhythm of gaps and built form



4.4.2.3 ROOF FORM

New development on existing streets **must**:

- Have pitched roof forms, reflective of surrounding prevailing form, e.g. gable ends or street-facing pitch
- Avoid flat roof forms facing streets on main roofs.
- Ensure dormers are set in a minimum of 1m from the roof edge, down 0.5m from the ridge and up 1m from the eaves, and not be dominant and out of proportion
- Flat-roofed dormers facing the street may be acceptable if the overall architectural design language of the development is **contemporary**, otherwise they must incorporate a roof which is compatible with the main roof



4.4.2.4 FRONT BOUNDARY TREATMENT

New development on existing streets **must** have:

- A defined front boundary that separates public realm from private space
- A clear pedestrian path to the front door, clearly defined from any frontage parking
- A boundary treatment such as a low wall, ornamental hedge or railings, making reference to prevailing styles on the street
- A front door that faces the street
- Sheltered, defensible threshold space at front door of at least 1m depth and 1.5m width
- An accessible covered space to store waste and recycling
- Accessibility to users of all abilities with a variety of mobility needs

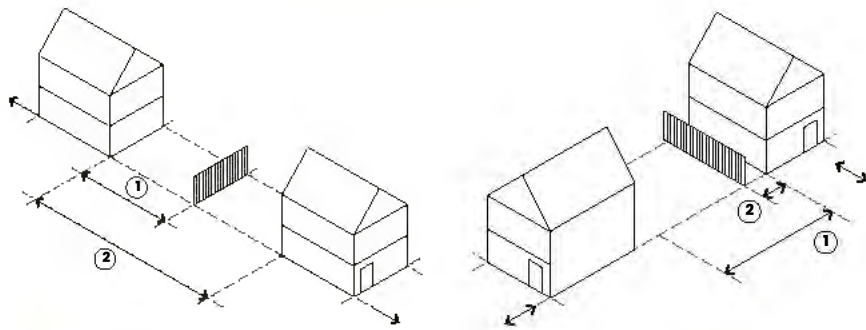

Maintain appropriate distances to existing properties

Left: Back to Back 21m (30m for 3 storey) (distance 2 on left diagram)

Right: Back to Flank 13.5m (21m for 3 storey) (distance 1 on right diagram)

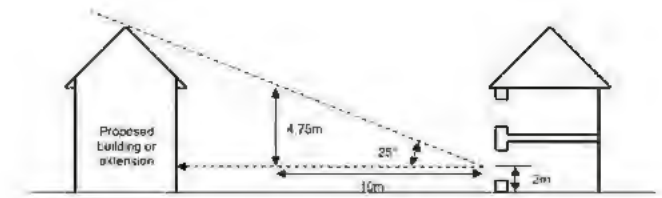

Ensure a 25° vertical line of sight to neighbouring properties to ensure daylight

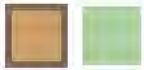

4.4.2.5 DAYLIGHT, PRIVACY AND OVERLOOKING

New development on existing streets **must**:

- Have a minimum back to back distance to properties at the rear of 21m (30m for 3 storey buildings)
- Ensure built form of two storeys or above is clear of a 45° line drawn from the centre of a habitable room in neighbouring properties, both horizontally and vertically
- Ensure a 25° vertical line of sight to neighbouring properties to ensure daylight
- Ensure a minimum back to flank distance 13.5m (21m for 3 storeys)
- Ensure a minimum boundary set-in distance 1m (2m for 3 storeys), or more to suit the context and prevailing street scene



4.4.2.6 ACCESS, CYCLE AND VEHICLE PARKING

New development on existing streets **must** have:

- Secure cycle parking provision, e.g. for apartments within a circulation core on ground floor
- If vehicle parking is provided, one of side, rear (shared), integrated or frontage car parking to be used
- Hardstanding for frontage car parking that occupies no more than 50% of frontage
- Brick paving or permeable gravel where car parking is on frontage
- Planting and permeable surfaces within shared car parking areas (for apartments)
- Pedestrian access to rear gardens



4.4.2.7 APARTMENT DEVELOPMENT

All new apartment development on existing streets **must** ensure:

- Dual aspect apartments are maximised
- Single aspect apartments are no deeper than 6m from an external window
- There are no single aspect apartments on north-facing aspects
- Balconies face the street and rear, avoiding balconies facing towards adjacent properties to sides
- That recessed or partially projecting balconies are used

Where no other private outdoor space is provided, balconies **must**:

- Have a minimum depth of 1500mm
- Have a minimum of 5m² of private outdoor space for all 2 person dwellings and an extra 1m² provided for each additional occupant.
- Have level access from a habitable room, ideally a living room or living area



4.4.2.8 DETAIL, RICHNESS AND MATERIALITY

New buildings on existing streets **should** demonstrate how they have incorporated common features seen in Suburban areas into their detailed design to enhance richness and variety in the street scene.



Softening built form with planting



Gable ends



Roof dormers



Hip roofs



Brickwork edge detailing

To enhance the richness of the street scene, new buildings on existing streets **could** incorporate features such as integrated garages and terraces, inset balconies for upper-floor apartments, and a variety of textures within elevation design.



Integrated garages and roof terrace design



Inset balconies on maisonette upper floors



Variety of textures and finishes on facade



New development on existing streets **must**:

- Use a single material for the elevation or;
- Have one clear change in materials between the ground floor and upper floors
- Use materials of high quality and long life, ideally with visible texture such as brick

4.4.3 Residential Extensions



OVERVIEW

The key design considerations for residential extensions on existing plots in Suburban areas are set out on this page.

All new residential extensions **must** comply with these requirements.

This section sets out an overview of the key dimensional requirements for residential extensions. More detailed guidance on design for this type of development is contained in Appendix C, drawn from the previously adopted *“Design of Residential Extensions and New Residential Development Supplementary Planning Document (SPD)” (April 2011)*.

4.4.3.1 CONTEXT & CHARACTER

Designs **should** be mindful of key dimensions of the wider context that will ensure an extension fits within and complements that character of the area. These include:

- Set-in distance: the distance from plot edge to the flank side of the building. It defines the characteristic width between properties along a street. Care should be taken to reflect the existing street scene.

- Set-back distance and prevailing building line
- Minimum requirements for key dimensions are set out on these pages.

Key characteristics to observe that extensions **should** respond to in architectural design include:

- Prevailing materials of the area
- Prevailing roof forms and features
- Rhythm of windows and location of front doors on façades

4.4.3.2 PRIVACY & OUTLOOK

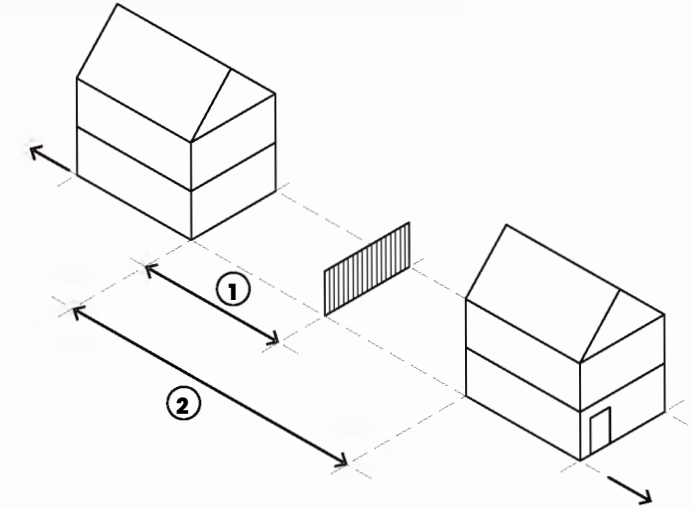

Minimum dimensions **must** be at least:

1. Garden length 10.5m (15m for 3 storeys)
2. Back to back distance 21m (30m for 3 storeys)

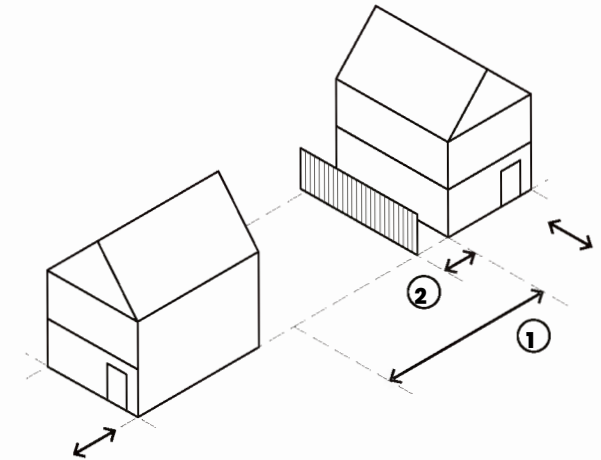

1. Back to flank distance 13.5m (21m for 3 storeys)
2. Boundary set-in distance 1m (2m for 3 storeys), or more to suit the context



Find out more background information about the borough in Appendix A ‘Understanding Spelthorne Today’.

4.4.3.3 DAYLIGHT

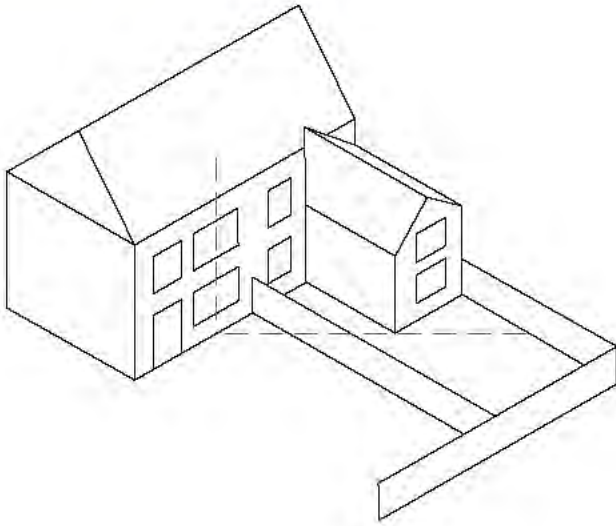

- Two-storey extensions **must** be clear of a 45° line drawn from the centre of a habitable room in neighbouring properties, both horizontally and vertically

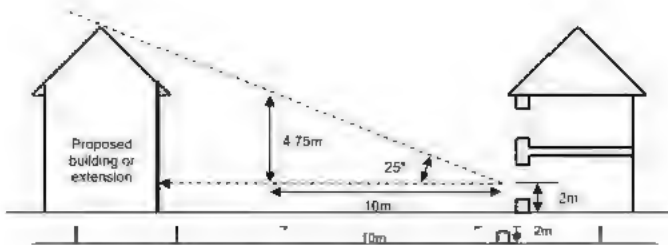

- Development **must** maintain a 25° vertical line of sight to neighbouring properties to ensure daylight

4.3.3.4 SIDE EXTENSIONS

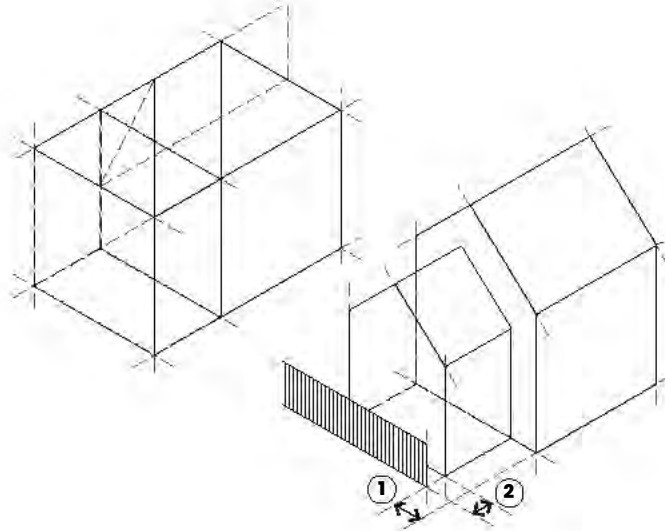

- Single storey side extensions **must** be set back from the main building line (1) by at least 300mm, and set in from the plot boundary (2) by at least 250mm
- Multi-storey side extensions **must** be set in from the plot boundary (2) by at least 1m (2m for 3 storey development), or more to suit the context
- Subordinate multi-storey side extensions **must** be set back from the main building line (1) by a minimum of 1m
- Inline side extensions may be acceptable in certain circumstances, particularly detached houses. Further guidance can be found in Appendix C.

4.4.3.5 DORMERS

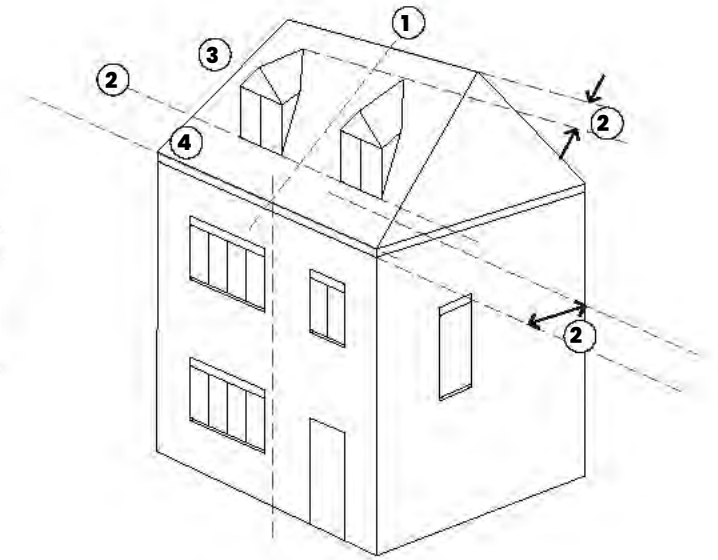

Dormers **must**:

- Be located centrally or symmetrically on a roof
- Be set in a minimum of 1m from the roof edge, down 0.5m from the ridge and up 1m from the eaves
- Incorporate a roof which is compatible with the main roof
- Not be dominant and out of proportion



Areas of Change

- » **5.1 Staines-upon-Thames Town Centre**
- » **5.2 Sunbury Cross**

5.1 Staines-upon-Thames Town Centre

OVERVIEW

This section sets out detailed Design Requirements and guidance for development in Staines-upon-Thames town centre.

EXTENT AND CONTEXT

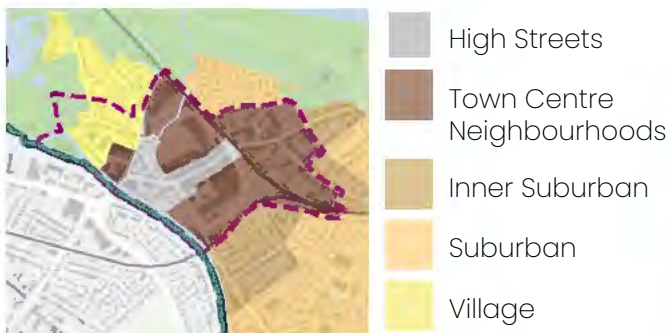

 Area of Change Boundary

 **Find out more** background information about the borough in Appendix A 'Understanding Spelthorne Today'.

 **Find out more** about the Conservation Area in the Staines Village Conservation Area Appraisal (2023).

 A clear vision for town centre neighbourhoods and the future 'look' of the town centre is a community priority.

DEVELOPMENT CONTEXT

Staines-upon-Thames town centre will see significant change in coming years. The [Local Plan](#) allocates around 3,500 new homes to be built, mostly at higher densities and resulting [floor area ratios](#) than the prevailing built form. The Design Code sets out the requirements for these to be delivered as part of coherent, well-designed Town Centre Neighbourhoods, that complement and enhance the existing High Street.



Recent development in Staines town centre: London Square (left), River Town (right)

DESIGN AIMS

New development in Staines-upon-Thames town centre **will**:

- When within 'Staines Village' and the 'Historic Core', respect and complement the context of the High Street, Clarence Street, Conservation Area and river frontage
- When within new town centre neighbourhoods, form part of coherent new places for people to live and enjoy that encourage connection, health and sustainable living
- Prioritise the quality, safety and attractiveness of the public realm, open spaces and streets
- Make the most of the river frontages and help improve connectivity to the Thames, Colne, Ash and Wraysbury rivers and the nearby natural environment
- Be resilient to the anticipated effects of climate change, and ensure that new places do not adversely affect existing places in terms of flooding, microclimate and quality of life
- Enhance connectivity to the railway and bus stations, and wider active travel networks

Area Types



Within the Area of Change, more detailed requirements are set out by finer-grain Area Types. Each Area Type in the town centre is considered by whether it will largely retain its existing character and contribution to overall place identity, or whether it is likely to change substantially in character and has the opportunity to newly contribute to the town's identity.

Incremental Change

Retaining existing character and place identity. Design requirements strongly reflect context.

↑	<ul style="list-style-type: none"> STAINES VILLAGE <hr style="border-top: 1px dashed black;"/> HISTORIC CORE General requirements for the High Street Area Type (see 4.1) apply. <hr style="border-top: 1px dashed black;"/> MEMORIAL GARDENS STATION PATH LONDON ROAD TWO RIVERS ELMSLEIGH RAILWAY EDGES 	<p>General requirements for the Town Centre Neighbourhoods Area Type (see 4.2) apply.</p>
---	--	---

Transformative Change

Defining a new character and place identity. Design requirements set key parameters only.

A SPATIAL APPROACH FOR STAINES-UPON-THAMES TOWN CENTRE

It is anticipated that the town centre of Staines-upon-Thames will see substantial new development in the coming years. The spatial approach sets out an overview of how this might be accomplished in line with the vision set out in Chapter 3. Although it is illustrative, it guides the detailed design requirements set out later in the Design Code.

The spatial approach's key aims are:

- To reflect the ambition of the community to preserve what makes the town special and familiar to them by identifying key streets and areas for incremental, small-scale change
- To define connected new town centre neighbourhoods that can accommodate new open spaces, new high-quality homes and new mixed-use facilities
- To enhance the character and future sustainability of the town centre

The spatial approach is a composite of a number of layers and design thinking that work together to guide development in the future in a coherent way. These are explored further on the following page.

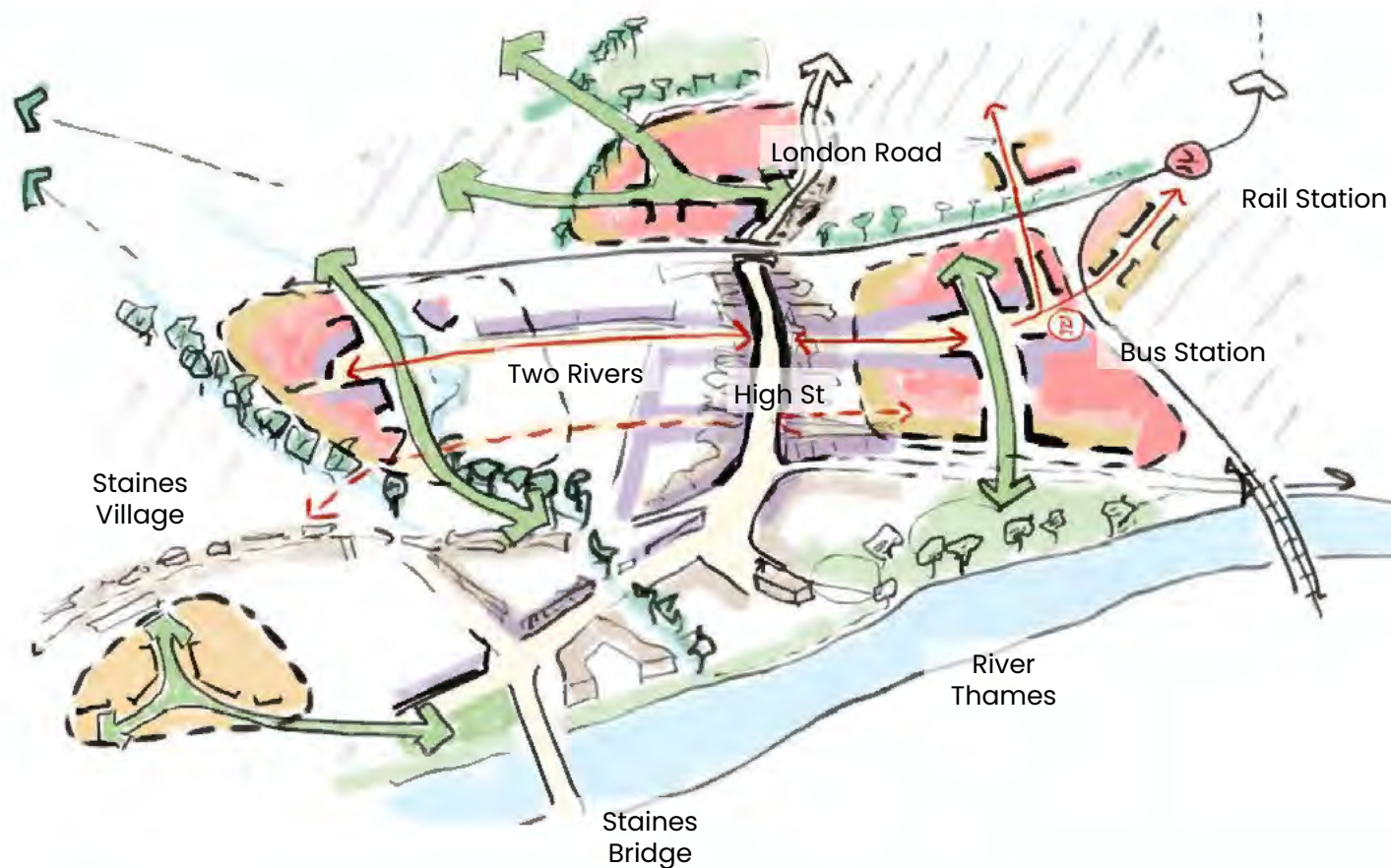

Protecting the historic core



Better spaces and connections



New green and blue spaces



New homes and spaces for people

PLACE IDENTITY



The places that are valued by the community and define the identity of Staines-upon-Thames form the core of the spatial approach.

GREEN LINKS

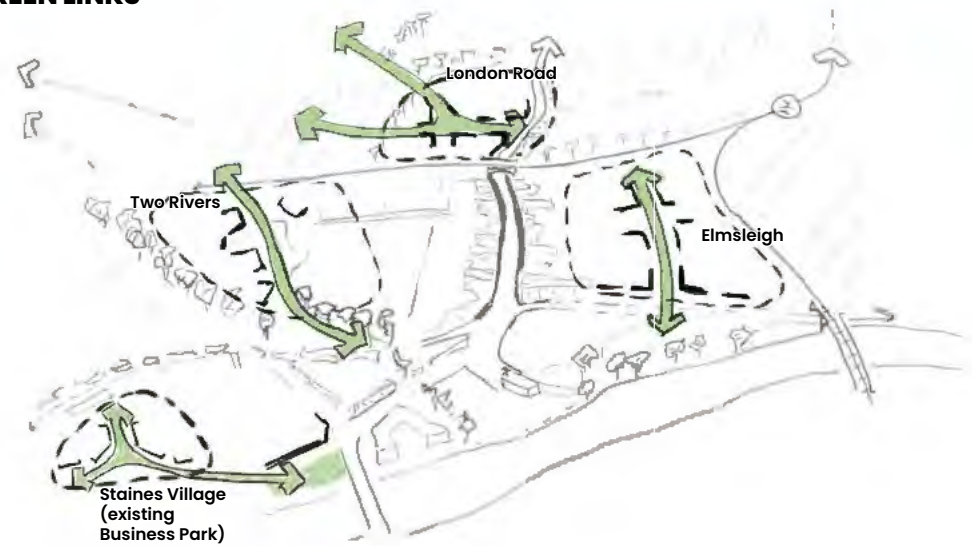

Areas of anticipated growth form new neighbourhoods, linked to their surrounding green open spaces and rivers through new green links.

STREET CONNECTIONS

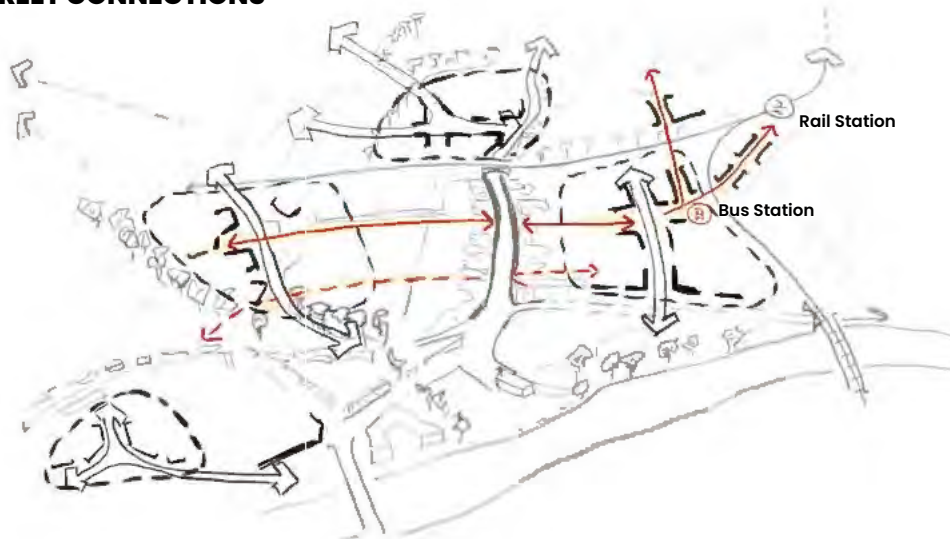

New neighbourhoods are linked and integrated to the High Street and surroundings through new walking and cycling street connections.

BUILT FORM AND USES

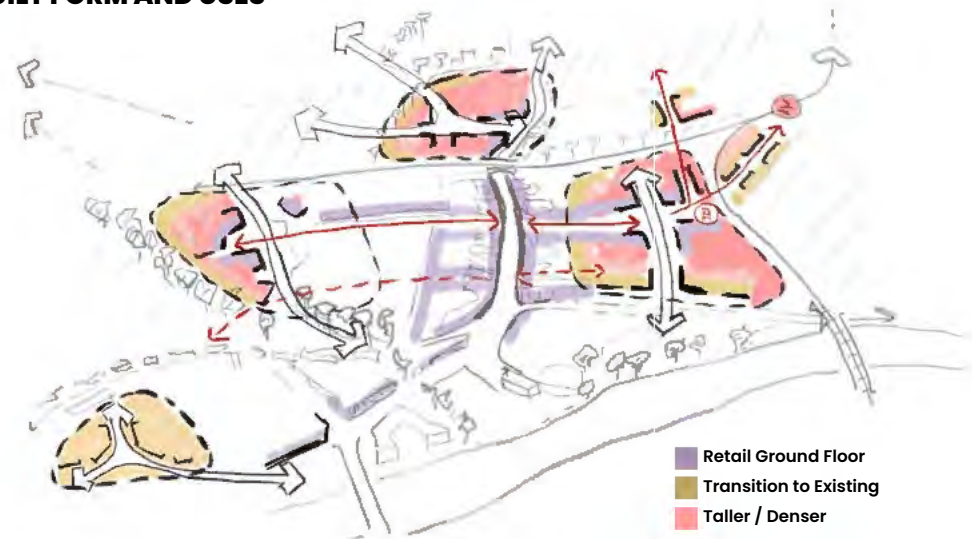

New built form is related to surrounding neighbourhoods by ensuring transitions in height. The existing retail core is strengthened and extended.

OVERALL TOWN CENTRE CODING STRATEGIES

Informed by the spatial approach, a range of strategies guide the detailed coding requirements across the town centre. The minimum requirements for individual schemes to implement these strategies are set out in the detailed Area Type Coding.

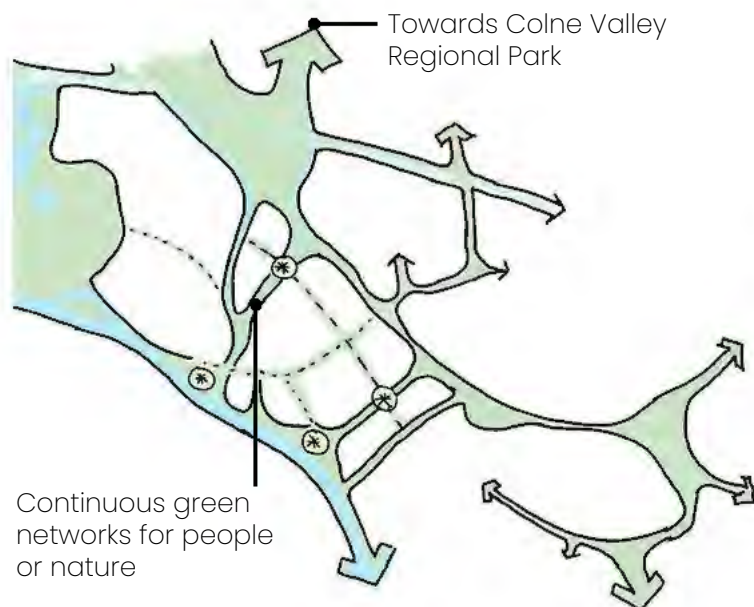

Green & Blue Networks

The town centre is surrounded by green and blue assets but is poorly connected to them. New development will join up and enhance the existing networks of green and blue infrastructure, for both people and nature to use.

This strategy will be implemented by creating and enhancing open spaces, new green streets, street transformations to include more planting, and enhancements to ecological networks.

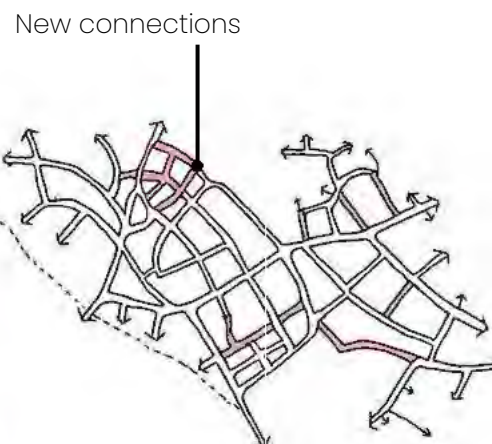

Movement

The town centre is broken up by railway lines, major dual carriageway roads and large buildings that prevent movement. New development will enhance the existing street grid so that people can find their way and move around easily, and by more sustainable modes.

This strategy will be implemented by creating new street connections, enhancing the quality of existing streets and joining up the dots of existing active travel provision.

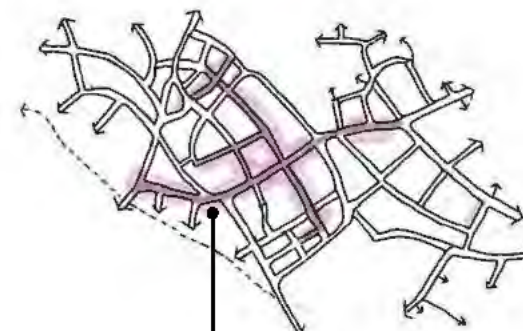

Uses & Facilities

The town centre has a strong existing High Street and retail offer, and new neighbourhoods will connect to and enhance them. New neighbourhoods will connect to and enhance the existing core of the town centre.

This strategy will be implemented by ensuring new streets and places have active commercial ground floors in the right places.

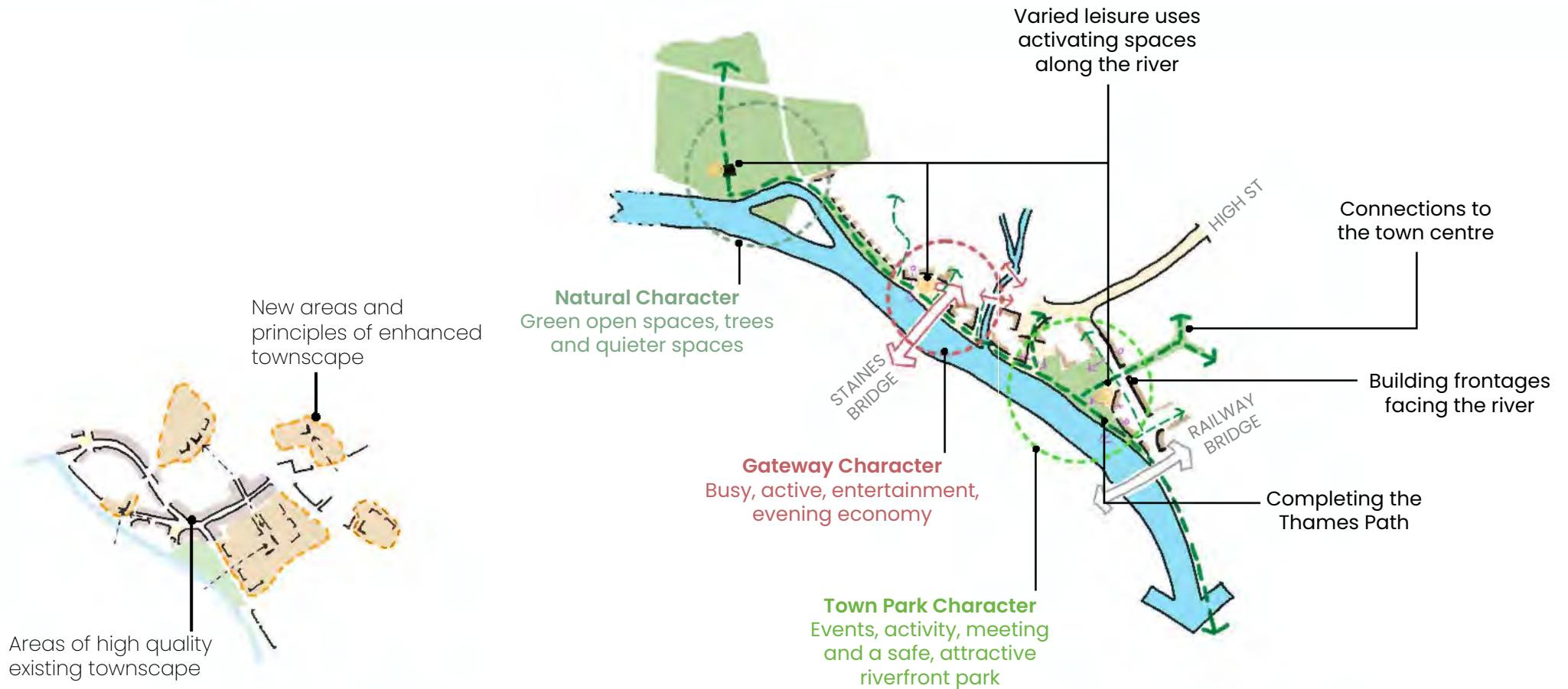

Townscape

The new town centre neighbourhoods strongly correspond to areas with poor existing townscape, where new development could significantly enhance how the town centre is experienced overall.

This strategy will be implemented by the requirements for the arrangement of new open spaces, streets, heights, **marker** and **landmark buildings**, and the implementation of town centre neighbourhood townscape principles (Chapter 4).

River Frontage

The River Thames that flows past Staines-upon-Thames is a vital part of the identity of the town. The overall strategy will be to establish or reinforce existing zones of activity, with attractive connections to the town centre, and development that fronts onto key spaces with complementary uses.

This strategy will be implemented by requirements for building heights, frontages, locations of open spaces, public realm priorities and key connectivity.

Relevant precedent examples for character of spaces and buildings are set out under 'Historic Core' and 'Memorial Gardens' Area Types.

5.1.1 Staines Village: Conserving a Valued and Attractive Place



DESIGN AIMS

New development will protect the existing attractive character of this area, with green space and small-scale urban grain.

Existing Context & Place Identity

Staines Village is a quiet, attractive area centred around St. Mary's Church and Church Street, becoming progressively greener as Church Street approaches the River Thames at its western end. There are many small, domestic, historic houses which are terraced and of red or buff brick or render with slate or tiled roofs. The character is residential and small-scale.

Much of the built form has a tight grain to it, which is set against the green open space around the Church. Towards the eastern end of Church St building heights rise, with a notable landmark at Courage Tower.

5.1.1.1 DESIGN REQUIREMENTS

Staines Village is covered by the Staines Village Conservation Area, and new development must take into account the existing character and context of this area. Development in this area type **must** comply with the following additional design requirements.

Where design requirements have a spatial requirement (e.g. location of key frontages) these are set out on the Area Type coding plan on the following page.

The Conservation Area covers the whole of this Area Type. Development in Staines Village should therefore preserve or enhance the character of the Conservation Area.

The characteristics of the Conservation Area **must** inform the approach to:

- Built Form **Massing**
- Building Line
- Built Form Grain
- Open Space Character
- Street Design and Public Realm
- Materials and Landscape
- Detailing and Architectural Approach

All designs must observe a rigorous **design process** that sets out why and how the above parameters have been arrived at from an appraisal of the existing Conservation Area.

The Area Type coding plan sets out key spatial considerations, particularly for the Staines Business Park allocated site.



Find out more about the Conservation Area in the Staines Village Conservation Area Appraisal (2023).



View west along Church Street showing tight urban grain, curve of street and continuous building line



Church Street curves and opens slightly, to allow for softening from front gardens and a varying width of space.



St Mary's Church anchors the western end of the Village with a generous churchyard and hinted views towards the River Thames.

AREA TYPE CODING PLAN

This plan sets out where design requirements apply within this Area Type.



Allocated site in Local Plan

THE STREET & GROUND FLOOR

←● Key View to Retain

..... Thames Path

--- New active travel street connection

SCALE & MASSING

▼▼ Sensitive Edge

BUILDING HEIGHTS PLAN

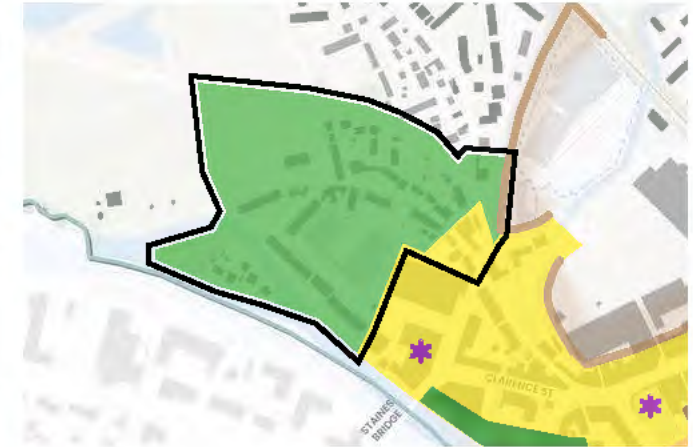

Heights typically up to:

■ 3-4 storeys (approx 12m)

■ 5-6 storeys (approx 18m)

Building heights are measured from pavement level to the roofline.

Typical storey heights for different uses are:

- Residential: 3m
- Commercial / Office: 4m
- Ground Floor Retail / Commercial: 4.5m

5.1.2 Historic Core: Retaining the Character of the Town's Heart

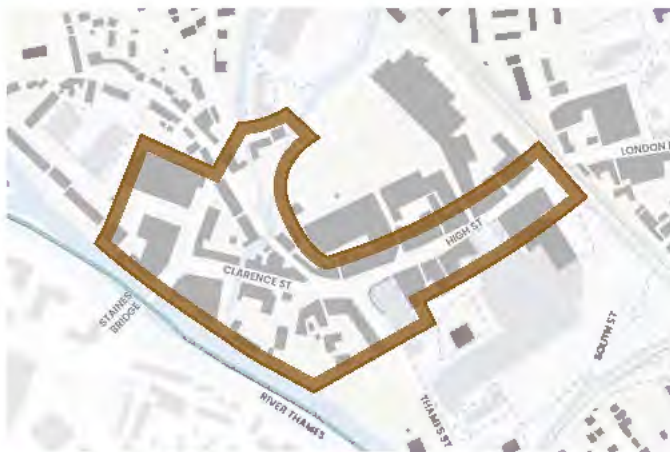

DESIGN AIMS

New development will strongly reflect the context, respecting its surroundings and retaining, not changing, the existing character.

Existing Context & Place Identity

The heart of Staines-upon-Thames is a vibrant and successful High Street. This grew up on the historic Roman road crossing Staines bridge leading towards London. It is primarily a retailing street, with high activity levels, on-street uses such as the market and local events and is at the heart of the identity of the town. The Conservation Area covers the western half of this Area Type.

The built form throughout this area is primarily 3-4 storeys (approx 12m), with a fine urban grain and attractive townscape. There are some on-street trees and only one major open space in the Market Square.

The public realm is bisected by a major road, and the overall built form historically turns its back on the river.

5.1.2.1 DESIGN REQUIREMENTS

General requirements for the **High Street Area Type** (see 4.1) apply. Part of the area is covered by the Staines Village Conservation Area, and new development must take into account the existing character and context. Development in this area type **must** comply with the following additional design requirements.

Where design requirements have a spatial requirement (e.g. location of key frontages) these are set out on the Area Type coding plan on the following page.

5.1.2.1a Building Heights

- Heights of between 3-6 storeys (approx 10-18m), to comply with the heights plan on the following page
- Protect the scale and characteristic aspect ratios of existing streets and spaces with development not dominating the street scene or materially altering its street section (shown in Sections 1, 2, 3 on the following pages).

5.1.2.1b Building Line

- Building line is continuous, with buildings set at the front of the plot

5.1.2.1c Building Grain

- Building widths of between 6-15m
- Building frontage grain of between 6-10m, with wider buildings visually subdivided

5.1.2.1d Vertical Mix of Uses

- Ground floor retail and flexible commercial uses included in designs where this frontage type is specified

5.1.2.1e Public Realm

- Create a river front open space as part of development adjacent to Staines Bridge, requirements set out under 'Key Open Space Requirements' on following page.
- Enhanced planting and trees along river frontage to provide shade and 'soft edge' to town centre
- Improvements to pedestrian crossing point between High Street and Market Square

5.1.2.1f Facades, Detail & Richness

- Retention of existing façades, where they are of historic or local importance, or are of distinctive and attractive architecture, and where this is technically feasible
- Roofs to be pitched, with a variety of forms acceptable (see Chapter 4) and informed by contextual study
- Windows on frontage to match surrounding rhythm and characteristics
- Materials and architectural detailing to respond to prevailing form
- Views along Clarence Street terminated with **marker buildings** to provide townscape interest



Find out more about the Conservation Area in the Staines Village Conservation Area Appraisal (2023).

AREA TYPE CODING PLAN

This plan sets out where design requirements apply within this Area Type.

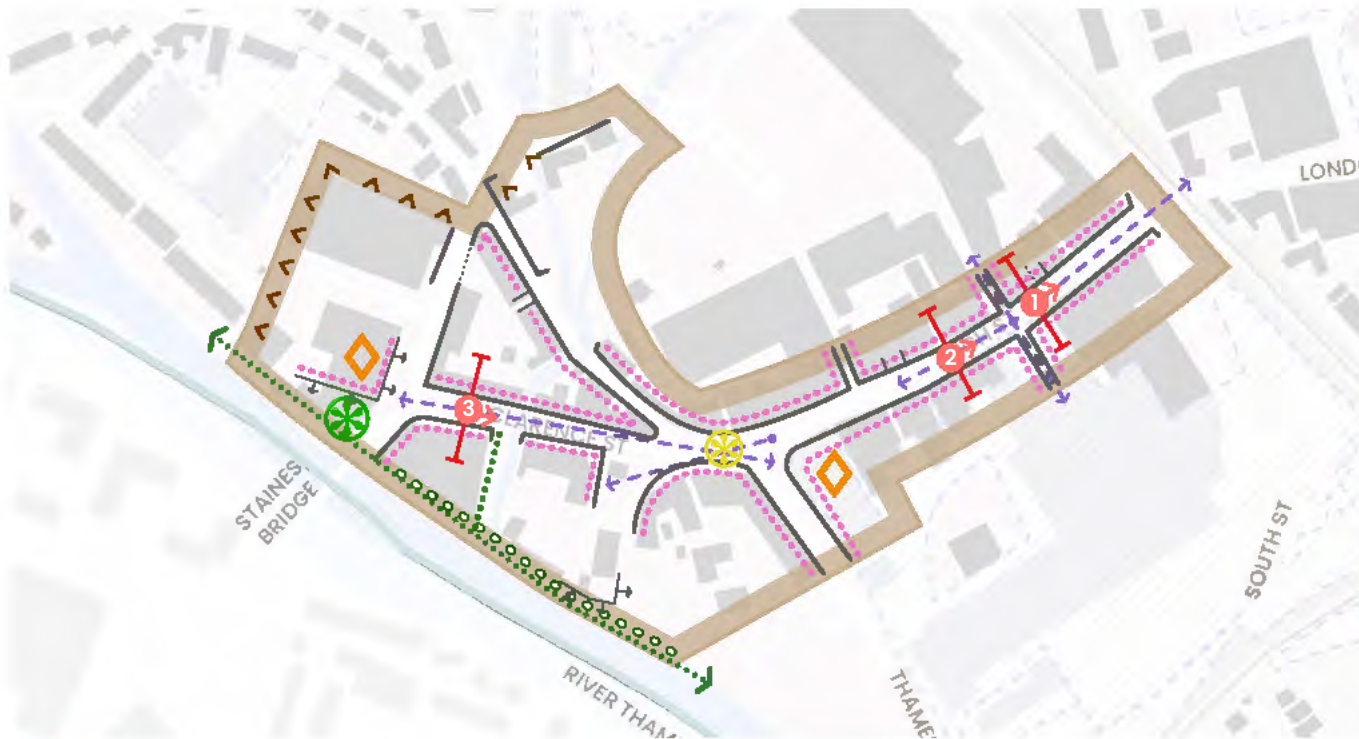

Section location

Allocated site in Local Plan

BUILT FORM

- Building Line
- New Active Frontage
- Key View to Retain
- Marker Building
- Sensitive Edge

VERTICAL MIX OF USES

- Retail / Flexible Commercial Ground Floor

PUBLIC REALM

- New green open space
- River frontage planting
- Public realm enhancements
- Thames Path and connecting paths

BUILDING HEIGHTS PLAN



Heights typically up to:

- 3-4 storeys (approx 12m)
- 5-6 storeys (approx 18m)

Locations where additional building height may be accepted, subject to:

- Review by an independent design review panel that includes community representation
- Additional height being set back from the street and sensitive edges
- Additional height complementing the wider townscape

Building heights are measured from pavement level to the roofline.

Typical storey heights for different uses are:

- Residential: 3m
- Commercial / Office: 4m
- Ground Floor Retail / Commercial: 4.5m

EXISTING STREET SECTIONS

The scale of key streets and spaces will be conserved and protected, with development not dominating the street scene or materially altering its street section

For section locations see Area Type Coding Plan.

High Street

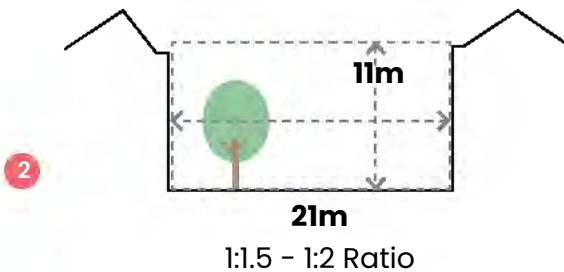
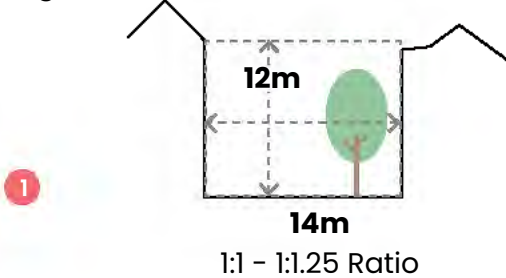

Clarence Street

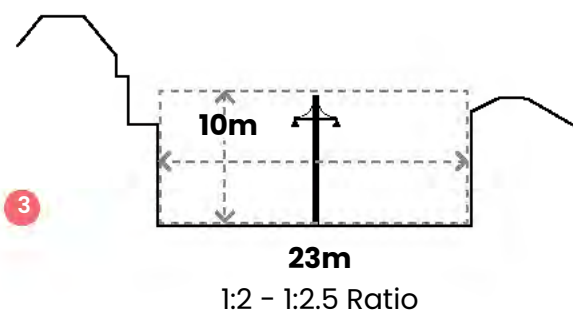

MATERIALITY AND DETAILING

The High Street, Market Square and Clarence Street have a wide range of architectural styles, materials and features, tied together by distinctive dimensions of height, width, and building form.



Gable end roof forms



Corner brickwork detailing and brick variation



Market Square - colonnades



Double-height window articulation



Decorative ironwork



Cream and yellow brick



Shades of red brick



White render

5.1.2.1g KEY OPEN SPACE REQUIREMENTS

Proposals for a new open space **must** include:

1. Thames Path running through space
2. Additional tree planting along frontage
3. Accessible connection between Clarence St and River Thames frontage
4. Opportunity for commercial reuse of bridge arches, with associated spill-out public realm
5. **Active frontages** at lower level facing river, with associated spill-out public realm
6. **Active frontage** at street level facing Bridge Street, with associated spill-out public realm
7. Open space with a mix of planted, treed and hard landscape

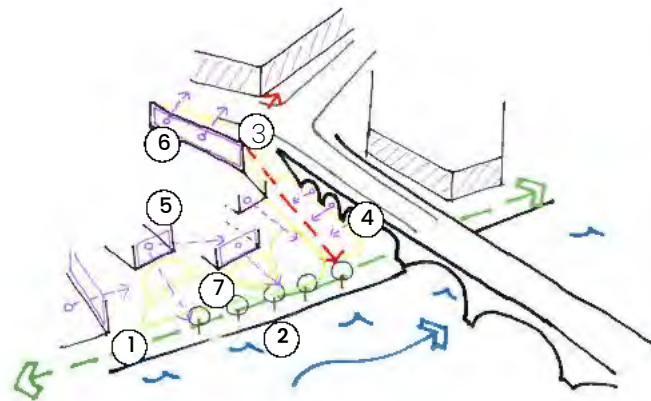

Illustrative approach to applying the key design requirements

EXAMPLES AND PRECEDENTS

Development in this area **could** implement the following design features, character and opportunities.



Providing spill-out space in the public realm through materials, planting, surface finishes and retractable canopies.



Creative use of existing heritage assets, frontages and spaces to bring back life and activity, such as the arches under Staines Bridge.



Creating new incidental spaces such as courtyards within development off main streets.



Activate the river frontage with planting, accessible landscape and lighting

5.1.3 Memorial Gardens: Improving and Respecting the River Thames Frontage



DESIGN AIMS

New development in this area of the Thames frontage will face the river, relate to and help to animate the green open space, and create new connections to the rest of the town centre. Any development will be of exceptional architectural quality and enhance the existing townscape.

Existing Context & Place Identity

The River Thames, and the bridge across it, is the primary reason for the existence of Staines-upon-Thames, and is a much valued asset.

Historically, the town 'turned its back' on the river, primarily seeing it as a location for industry and other marginal uses, and it has only been in the latter stages of the 20th century that its value as a leisure and recreation asset has been recognised, with the creation of Memorial Gardens and the Thames Path national long-distance footpath running through the town.

5.1.3.1 DESIGN REQUIREMENTS

General requirements for the **Town Centre Neighbourhoods Area Type** (see 4.2) apply. Development in this area type **must** comply with the following additional design requirements.

Where design requirements have a spatial requirement (e.g. location of key frontages) these are set out on the Area Type coding plan on the following page.

5.1.3.1a The Street & Ground Floor

- Building line to be continuous along Thames Street. Setback from plot edge of at least 2m to provide additional public realm for use as spill-out space or planting
- Extend the Thames Path along the full extents of river frontage from Memorial Gardens to the railway bridge
- Planting and trees accommodated along Thames St in areas of extended public realm.
- Ground floor retail and flexible commercial uses where this frontage type is specified.
- Frontages to activate Memorial Gardens

5.1.3.1b Scale & Massing

- Heights to comply with the maximum heights plan and key principles in Sections 1 and 2 on the following pages
- Building widths of 10-25m
- Appropriate development typologies include Villas and linear blocks

5.1.3.1c Open Spaces

- Buildings to face Memorial Gardens
- Extend Memorial Gardens onto the existing car park, design requirements set out under 'Key Open Space Requirements' on following page.
- Extend the green open space network from Memorial Gardens towards the northwest

5.1.3.1d Detail & Richness

- Roofs to contribute to townscape with pitched form, and with variation when viewed from a distance.
- Building frontage grain of 10-15m, with wider buildings visually subdivided
- **Marker and landmark buildings** at key locations to provide legibility and townscape interest, reflecting principles set out under **4.2.5.2**. See Area Type Coding Plan
- 3-4 storey landmark mixed-use building opportunity adjacent to Memorial Gardens, anchoring the extended space

AREA TYPE CODING PLAN

This plan sets out where design requirements apply within this Area Type.



- Section location
- Allocated site in Local Plan
- THE STREET & GROUND FLOOR**
- Building Line
- New Active Frontage
- Retail / Flexible Commercial Ground Floor
- Key Overlooking Location
- Existing path or active travel street to connect to
- New active travel street connection
- OPEN SPACES**
- New green open space
- Extension to public realm
- Street Planting & Greening
- DETAIL & RICHNESS**
- Marker Building
- Landmark Building

BUILDING HEIGHTS PLAN



- Heights typically up to:
- 3-4 storeys (approx 12m)
 - 5-6 storeys (approx 18m)
 - 8 storeys (approx 24m)

See Sections 1 and 2 on following page for explanation and key principles on heights.

Building heights are measured from pavement level to the roofline.

Typical storey heights for different uses are:

- Residential: 3m
- Commercial / Office: 4m
- Ground Floor Retail / Commercial: 4.5m

(5.1.3.1b) HEIGHTS AND SCALE PRINCIPLES

This diagram illustrates overall principles and rationale for the scale and **massing** in the river frontage area. These are set out to protect the scale and character of the riverside frontage.

For locations of sections see Area Type Coding Plan on previous page.

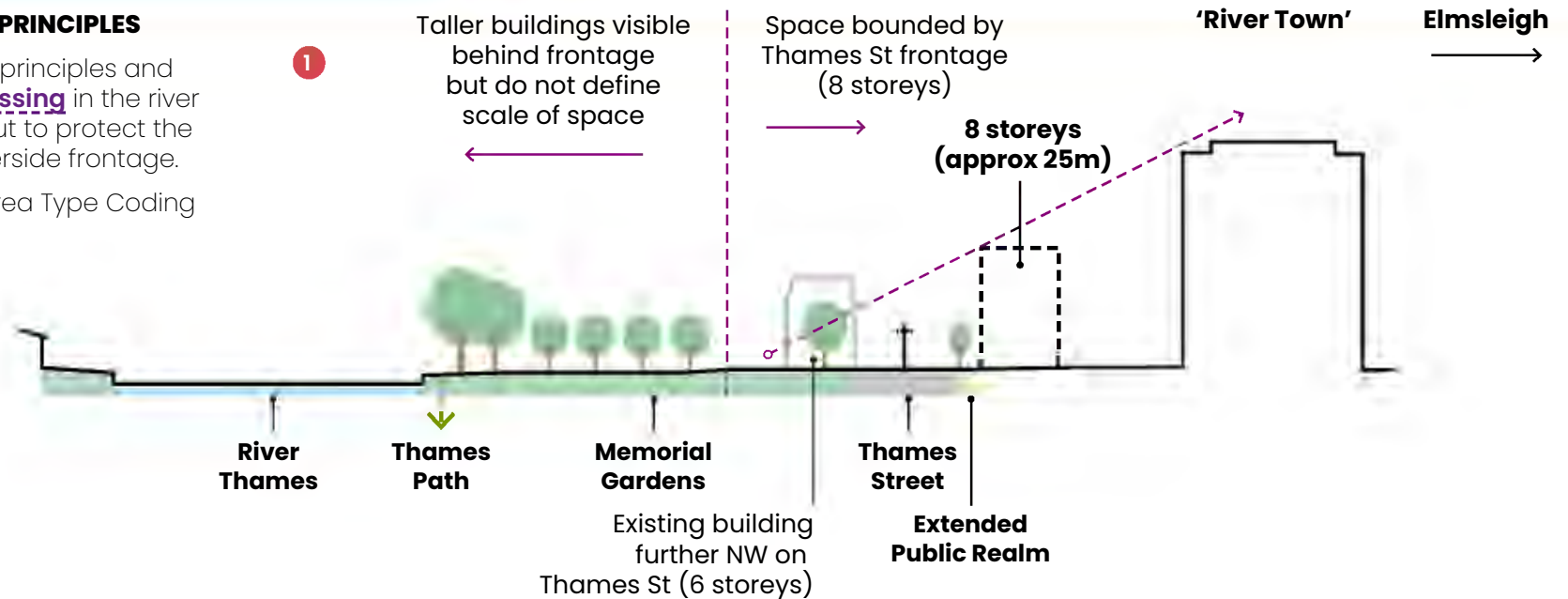

Key principles for **massing** are that development **must**:

- Have a frontage along Thames Street should at a maximum of 8 storeys (approx 24m) to retain an appropriate scale to Memorial Gardens, and to reduce the impact of taller buildings set back behind Thames Street
- Have maximum heights on the river side of Thames Street should be similar to those already in existence (up to 6 storeys, approx 18m, immediately adjacent to Thames Street)
- Have maximum heights on the river side of Thames Street which step down towards the river frontage where they should not exceed 3 storeys (approx 10m) immediately adjacent to the river
- Have building mass that is broken up with variety in heights, roofscape and articulation of façades

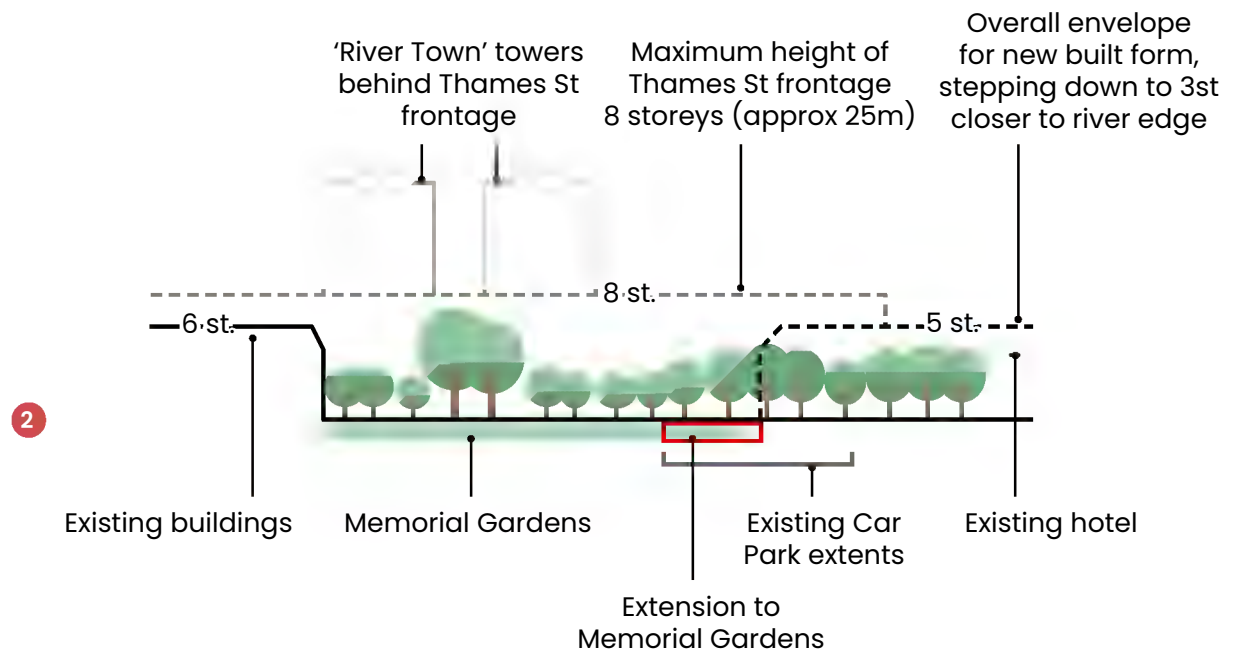

5.1.3.1e KEY OPEN SPACE REQUIREMENTS

Proposals for a new open space **must** include:

1. Thames Path running through space, extended along river front with overlooking from built form
2. Accessible connections and improved crossing across Thames St
3. West or Southwest facing **active frontage** facing river and green open space with associated spill-out public realm
4. **Active frontage** on Thames St
5. Extension of existing green open space
6. Additional tree planting

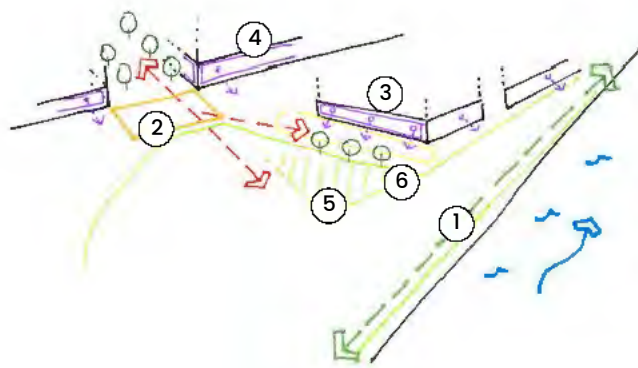

Illustrative approach to applying the key design requirements

EXAMPLES AND PRECEDENTS

Development in this area **could** implement the following design features, character and opportunities.



Use of hard landscape public realm to support active ground floor uses on the edge of Memorial Gardens, with trees for shade and to provide a transition to greener open space in Memorial Gardens.



Fine-grained, varied frontages that address the river, open up views and connections, and provide overlooking to Memorial Gardens without overwhelming the scale of the space.



Activating open space with play and landscape features to encourage the use of Memorial Gardens as a destination, with play, seating and other activities available.



Use of gable-end and set back roofs to provide interest and variety to building tops, and usable private outdoor space facing the river.

5.1.4 Station Path: Improving Connections and Integrating Development Sensitive



DESIGN AIMS

New development in this area will realise the potential of the sustainable location close to the railway station. It will benefit the surroundings by enhancing the Station Path, providing safe and attractive links between the path and Kingston Road, and reducing areas of severance and discontinuity. It will relate respectfully in scale and massing to the residential area to the north.

Existing Context & Place Identity

The Station Path is an important gateway to the town and has an attractive green character, but is bordered by car parks and underused spaces that can make it feel unsafe.

Community and commercial uses, along with apartments, are located on Kingston Road. A mix of Victorian and Edwardian homes are interspersed with more modern, less well-integrated development and surface parking.

5.1.4.1 DESIGN REQUIREMENTS

General requirements for the **Town Centre Neighbourhoods Area Type** (see 4.2) apply. Development in this area type **must** comply with the following additional design requirements.

Where design requirements have a spatial requirement (e.g. location of key frontages) these are set out on the Area Type coding plan on the following page.

5.1.4.1a The Street & Ground Floor

- Match and repair existing building lines.
- Provide a setback along Station Path for seating and planting.
- Provide passive surveillance of Station Path, particularly the railway underpass and surrounding area
- Pedestrian and cycle links between Kingston Road and the Station Path
- Street network to respect and connect to existing street grid and characteristic blocks of 55-75m width

5.1.4.1b Scale & Massing

- Heights to transition to surrounding built form as set out on the transitional edges plan and key principles in Section 1 on following pages
- Building widths or frontage grain of between 7-15m to reflect existing built form
- Appropriate development typologies include terraces, mews, linear blocks, villas and occasional towers on podiums.

5.1.4.1c Open Spaces

- Create a square in front of the Oast House which provides an appropriately-scaled space for this building. Requirements are set out under 'Key Open Space Requirements' on following page.

5.1.4.1d Detail & Richness

- Roofs up to 5 storeys (approx 15m) to be pitched with gable ends and dormers acceptable.
- Roofs of taller buildings to provide visual interest with distinctive form, and with variation when viewed from a distance.
- **Marker buildings** at key locations to provide legibility and townscape interest, reflecting principles set out under **4.2.5.2**. See Area Type Coding Plan.

AREA TYPE CODING PLAN

This plan sets out where design requirements apply within this Area Type.

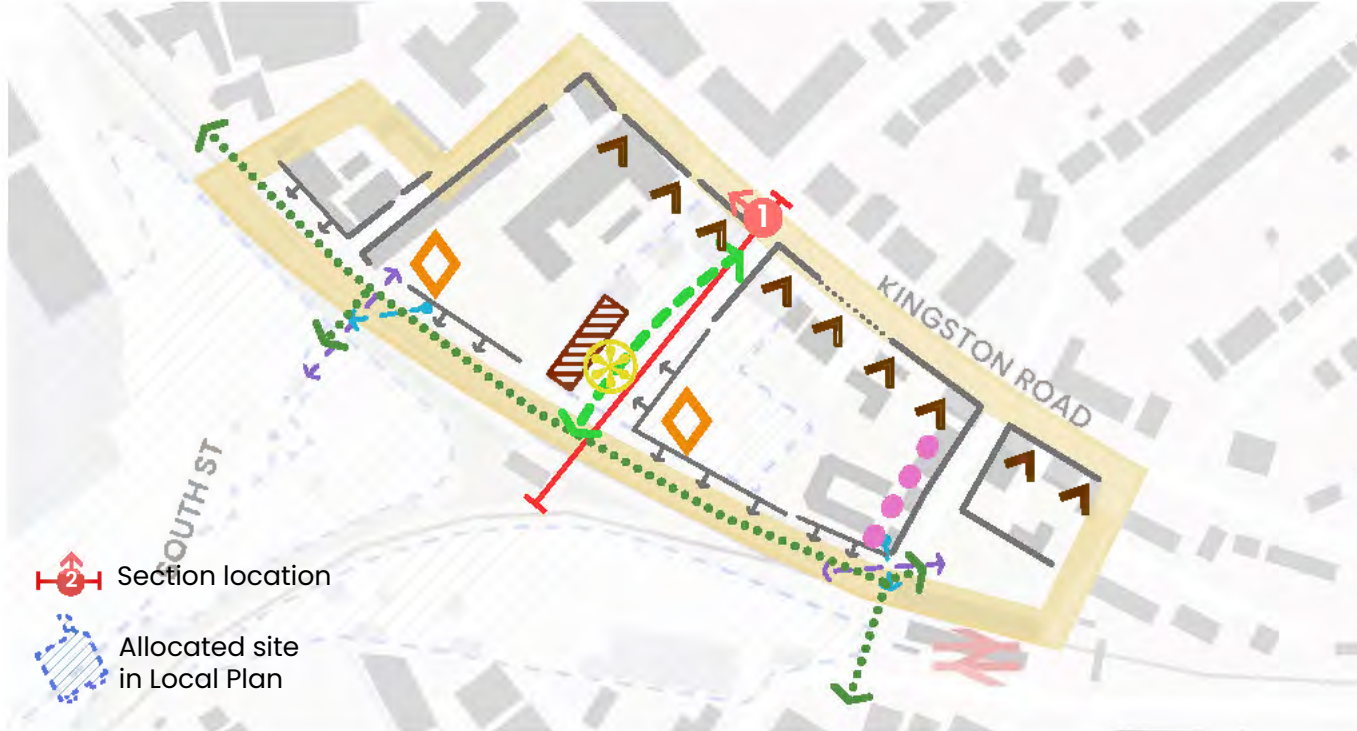

- | | | |
|--|---|---|
| <p>THE STREET & GROUND FLOOR</p> <ul style="list-style-type: none"> Building Line New Active Frontage Key View to Retain Retail / Flexible Commercial Ground Floor Repaired Building Line | <ul style="list-style-type: none"> Key Overlooking Location Existing path or active travel street to connect to New active travel street connection <p>SCALE & MASSING</p> <ul style="list-style-type: none"> Sensitive Edge | <p>OPEN SPACES</p> <ul style="list-style-type: none"> Public realm enhancements <p>DETAIL & RICHNESS</p> <ul style="list-style-type: none"> Marker Building Heritage Asset to define edge of new public realm |
|--|---|---|

TRANSITIONAL EDGES PLAN



Transitional Edge, where heights step down to blend with prevailing built form and preserve street scale.

See Section 1 on following page for explanation and key principles on transitional edges.

(5.1.4.1b) HEIGHTS AND SCALE PRINCIPLES

This diagram illustrates overall principles for the scale and **massing** in the Station Path area.

For section location see Area Type Coding Plan.

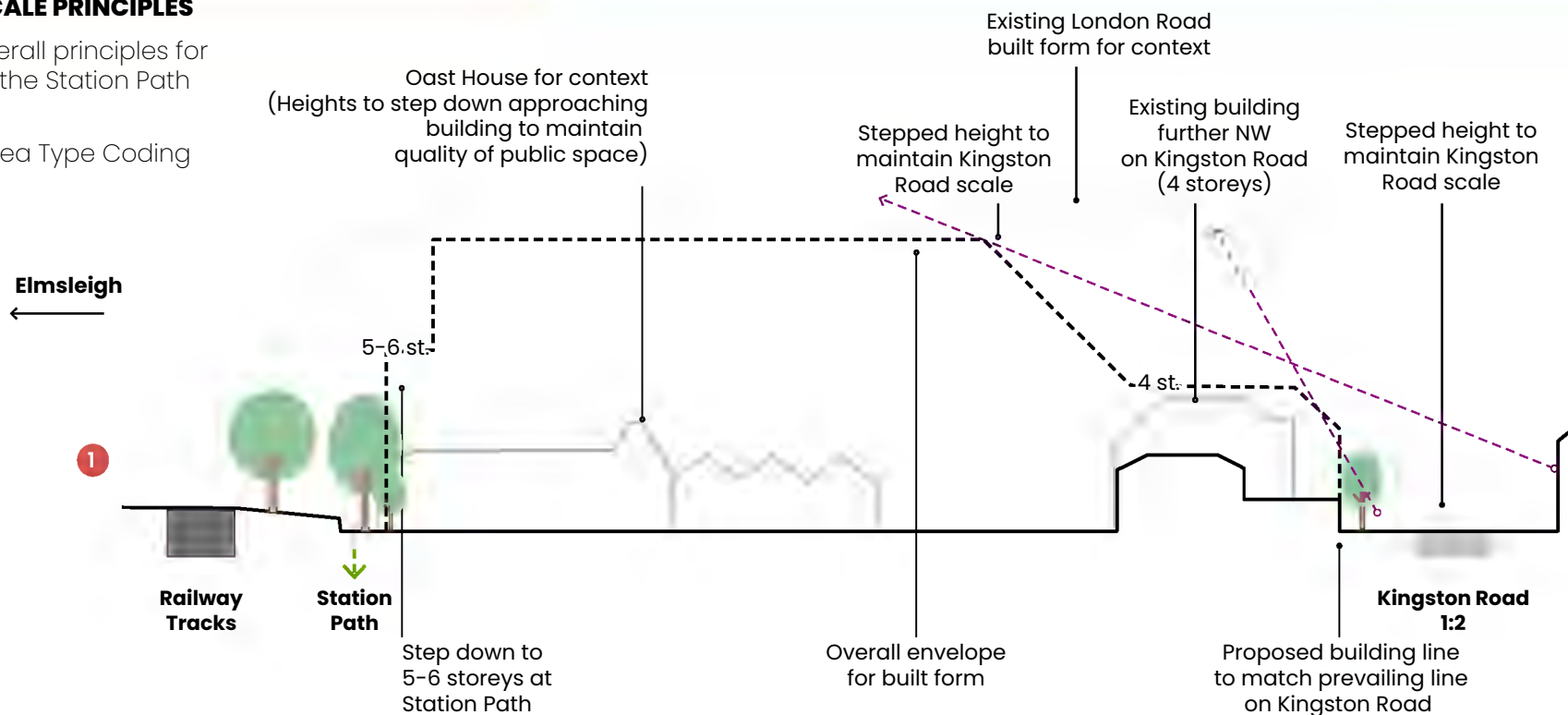

Key principles for **massing** are that development **must**:

- Step down to 3-4 storeys (approx 12m) to meet Kingston Road towards the east, preserving its scale and views from the street and buildings to the north
- Step down to 5-6 storeys (approx 18m) to meet Kingston Road towards the west, closer to London Road
- Step down to 5-6 storeys (approx 18m) create a human scale adjacent to Station path
- Step down to meet the public space in front of the Oast House as set out in the Key Open Space Requirements on the following page

5.1.4.1e KEY OPEN SPACE REQUIREMENTS

Proposals for a new open space **must** include:

1. Improved overlooking of Station Path
2. Walking and cycling connection between Kingston Road and Station Path
3. Public space created in front of Oast House with new surrounding built form scaled and set back at taller heights, as shown in section inset.
4. 'Spill-out' public realm immediately in front of Oast House
5. Tree planting within public realm to provide shade and character to space
6. Overlooking and **active frontages** to all spaces from new built form

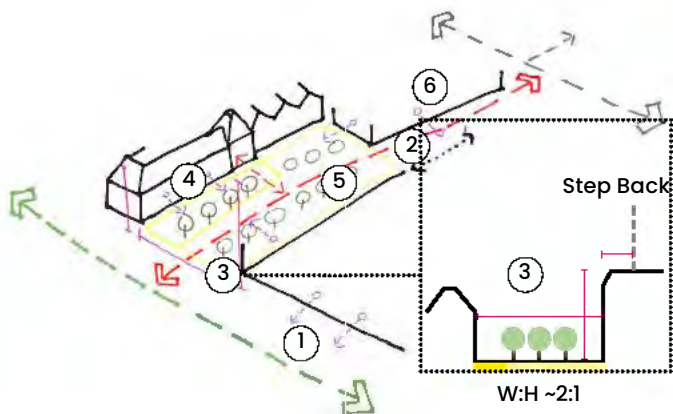

Illustrative approach to applying the key design requirements

EXAMPLES AND PRECEDENTS

Development in this area **could** implement the following design features, character and opportunities.



Streets that prioritise people and limit vehicle speeds, and reflect the existing structure and key dimensions of blocks and streets in the surrounding context.



Use of artwork in the public realm to provide legibility and a distinctive character to this area, particularly on new pedestrian links past the Oast House.



Use of mews streets to ensure high densities within blocks whilst maintaining a mix of house types in developments.

5.1.5 London Road: A New Gateway Neighbourhood for the Town Centre



DESIGN AIMS

New development in this area will create new high-quality green spaces and public realm for residents and the public that provide a setting for higher-density buildings, and maximise connectivity through to the suburbs and green spaces to the north.

Existing Context & Place Identity

On the north-eastern side of the railway tracks, under the Iron Bridge, the London Road area is an extension of the High Street. It has some secondary and local retail and service uses, as well as being a focus for a number of larger high-density residential schemes, with associated ground floor retail uses.

London Road is an important gateway location for the town and is a major new neighbourhood for Staines-upon-Thames.

5.1.5.1 DESIGN REQUIREMENTS

General requirements for the **Town Centre Neighbourhoods Area Type** (see 4.2) apply. Development in this area type **must** comply with the following additional design requirements.

Where design requirements have a spatial requirement (e.g. location of key frontages) these are set out on the Area Type coding plan on the following page.

5.1.5.1a The Street & Ground Floor

- Building line to be set back from plot edge along London Road to provide additional public realm, planting and spill-out space.
- Retail and commercial ground floor uses to be located along London Road frontage

5.1.5.1b Scale & Massing

- Heights to transition to surrounding built form as set out on the transitional edges plan and key principles in Section 1 on following pages
- General presumption of high residential densities and **Floor Area Ratio** of 3.0 or above.
- Appropriate development typologies include occasional podiums and towers, villas and linear blocks.

5.1.5.1c Open Spaces

- Create a linear green open space from London Road/Kingston Road towards the north. Requirements are set out under 'Key Open Space Requirements' on following page.

5.1.5.1d Detail & Richness

- Roofs of taller buildings should provide visual interest with distinctive form, and with variation when viewed from a distance.
- **Marker buildings** at key locations to provide legibility and townscape interest, reflecting principles set out under **4.2.5.2**. See Area Type Coding Plan.

AREA TYPE CODING PLAN

This plan sets out where design requirements apply within this Area Type.



Section location

Allocated site in Local Plan

THE STREET & GROUND FLOOR

- Building Line
- ↕ New Active Frontage
- ←-● Key View to Retain
- Retail / Flexible Commercial Ground Floor

- ←-● Key Overlooking Location
- ⋯ Existing path or active travel street to connect to
- - - New active travel street connection

- SCALE & MASSING
- ∨∨ Sensitive Edge

- OPEN SPACES
- ⊗ New green open space
 - ⊗ Public realm enhancements
 - Street Planting & Greening

- DETAIL & RICHNESS
- ◇ Marker Building

TRANSITIONAL EDGES PLAN

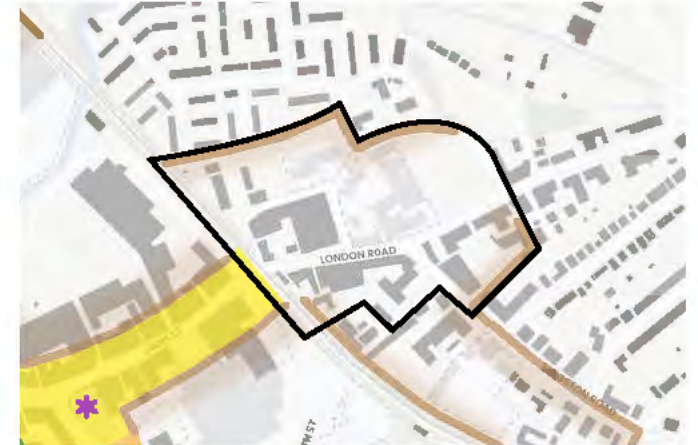

Transitional Edge, where heights step down to blend with prevailing built form and preserve street scale.

See Section 1 on following page for explanation and key principles on transitional edges.

(5.1.5.1b) HEIGHTS AND SCALE PRINCIPLES

This diagram illustrates overall principles for the scale and **massing** in the London Road area.

For section location see Area Type Coding Plan.

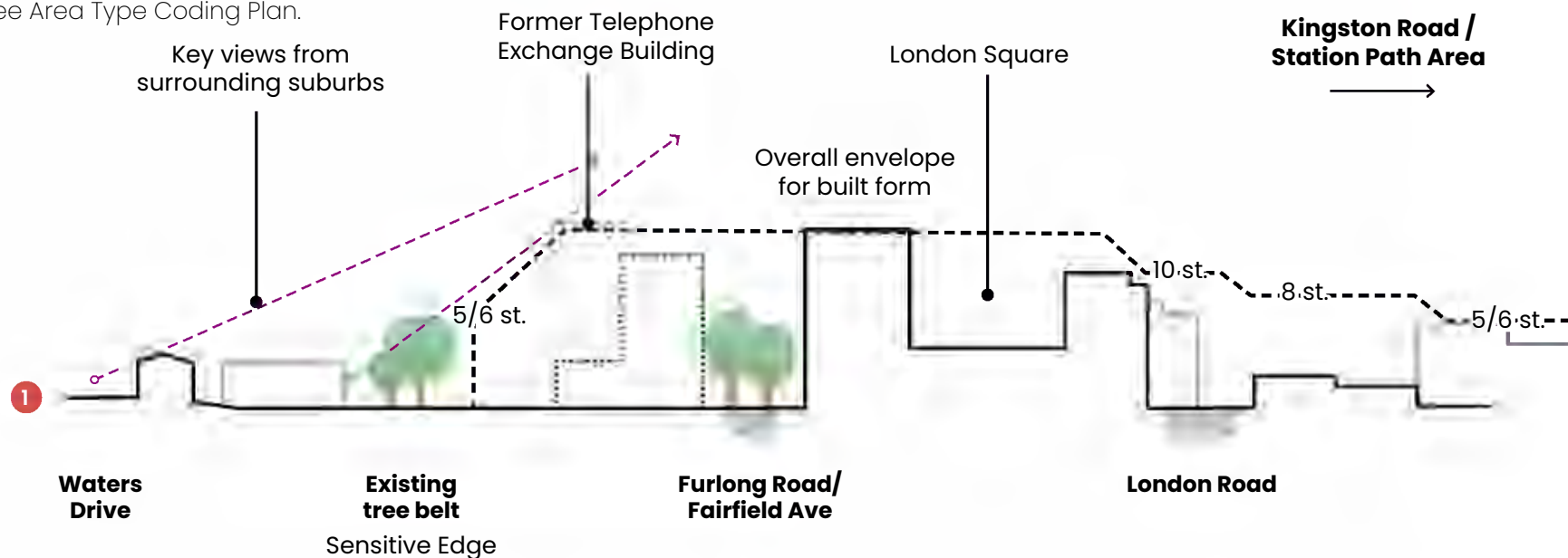

Key principles for **massing** are that development **must:**

- Step down towards the northern edge bordering Waters Drive to approximately match the heights of the existing tree belt (5/6 storeys, approx 18m)
- Heights to peak in the centre of the neighbourhood at 12 storeys (approx 36-40m)
- Heights on London Road to be no higher than the currently prevailing heights of recent developments (approx 10 storeys / 32m)
- Be generally lower in height on the south-western side of London Road to transition to this lower-rise existing residential area

5.1.5.1e KEY OPEN SPACE REQUIREMENTS

Proposals for a new open space **must** include:

1. Connections to wider open spaces and neighbourhoods to the north
2. Retention of existing trees
3. Overlooked public realm at key node
4. Connection from London Road to former Telephone Exchange site and public realm
5. Overlooked linear green open space
6. Improved pedestrian and cycling connections at London Road / Kingston Road junction
7. Retail frontage and associated 'spill-out' public realm on London Road
8. **Marker building** to terminate views along linear green open space

EXAMPLES AND PRECEDENTS

Development in this area **could** implement the following design features, character and opportunities.



Well-overlooked green open spaces with trees, seating and a choice of walking routes.



Active commercial ground floors that have a strong relationship with a pedestrian-friendly public realm.

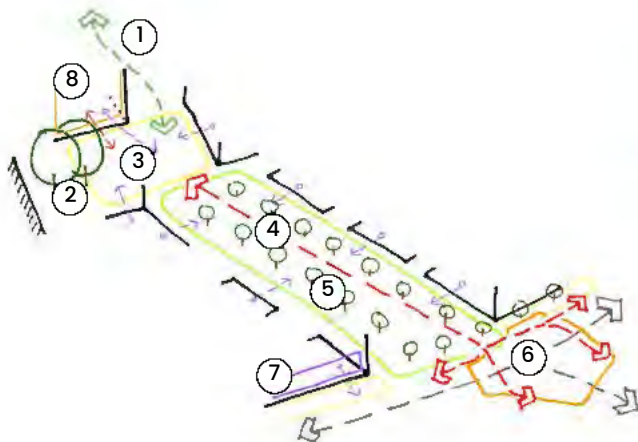

Illustrative approach to applying the key design requirements



Urban character of public realm with trees, cycle parking and hard landscape at key nodes, such as along London Road or at the public realm square opportunity set out on the coding plan.

5.1.6 Two Rivers: A New Neighbourhood with access to Nature



DESIGN AIMS

New development in the Two Rivers area will create a new, integrated primarily residential neighbourhood strongly related to the watercourses running through it. Opportunities to reflect the grain or character of the historic industrial uses of the site are supported.

Existing Context & Place Identity

To the north-west of the core of the historic town centre sits the Two Rivers Retail Park, which occupies land previously used for the linoleum industry. The area is dominated by a large surface car park and associated highway infrastructure and edged by modern retail and leisure units. The retail park integrates well with the core High Street and strengthens the overall town centre offer.

5.1.6.1 DESIGN REQUIREMENTS

General requirements for the **Town Centre Neighbourhoods Area Type** (see 4.2) apply. Development in this area type **must** comply with the following additional design requirements.

Where design requirements have a spatial requirement (e.g. location of key frontages) these are set out on the Area Type coding plan on the following page.

5.1.6.1a The Street & Ground Floor

- New street layouts designed on 'superblock' principles to prioritise active travel, with vehicle movement limited to parking and service access to buildings
- New streets to connect to and extend the street grid of the town centre from the southeast
- Enhance the safety of the existing pedestrian bridge towards the west by locating of built form with **active frontages** facing it
- Connect new streets to existing footpaths along River Wraysbury corridor
- Retention and extension of retail, leisure and other commercial uses along key NW-SE axis. See Area Type Coding Plan.

5.1.6.1b Scale & Massing

- Heights to transition to surrounding built form as set out on the transitional edges plan and key principles in Section 1 on following pages
- **Massing** led by creating a comfortable street scale with the tightest width:height ratio of around 1:1. Heights that would break this street aspect ratio are permitted through the use of a **shoulder** where heights step back from the street edge.

- General presumption of high residential densities and **Floor Area Ratio** of 3.0 or above.
- Terraces and linear blocks to be used close to sensitive edges.
- All development typologies may be appropriate in other locations

5.1.6.1c Open Spaces

- Create a new linear park and public spaces along a restored River Colne. Requirements are set out under 'Key Open Space Requirements' on following page.
- Enhancement of the habitats and watercourses of the Rivers Wraysbury and Colne, including potential for river restoration approaches along the Colne.

5.1.6.1d Detail & Richness

- Roofs of taller buildings should provide visual interest with distinctive form, and with variation when viewed from a distance.
- **Marker and landmark buildings** at key locations to provide legibility and townscape interest, reflecting principles set out under **4.2.5.2**. See Area Type Coding Plan.

AREA TYPE CODING PLAN

This plan sets out where design requirements apply within this Area Type.

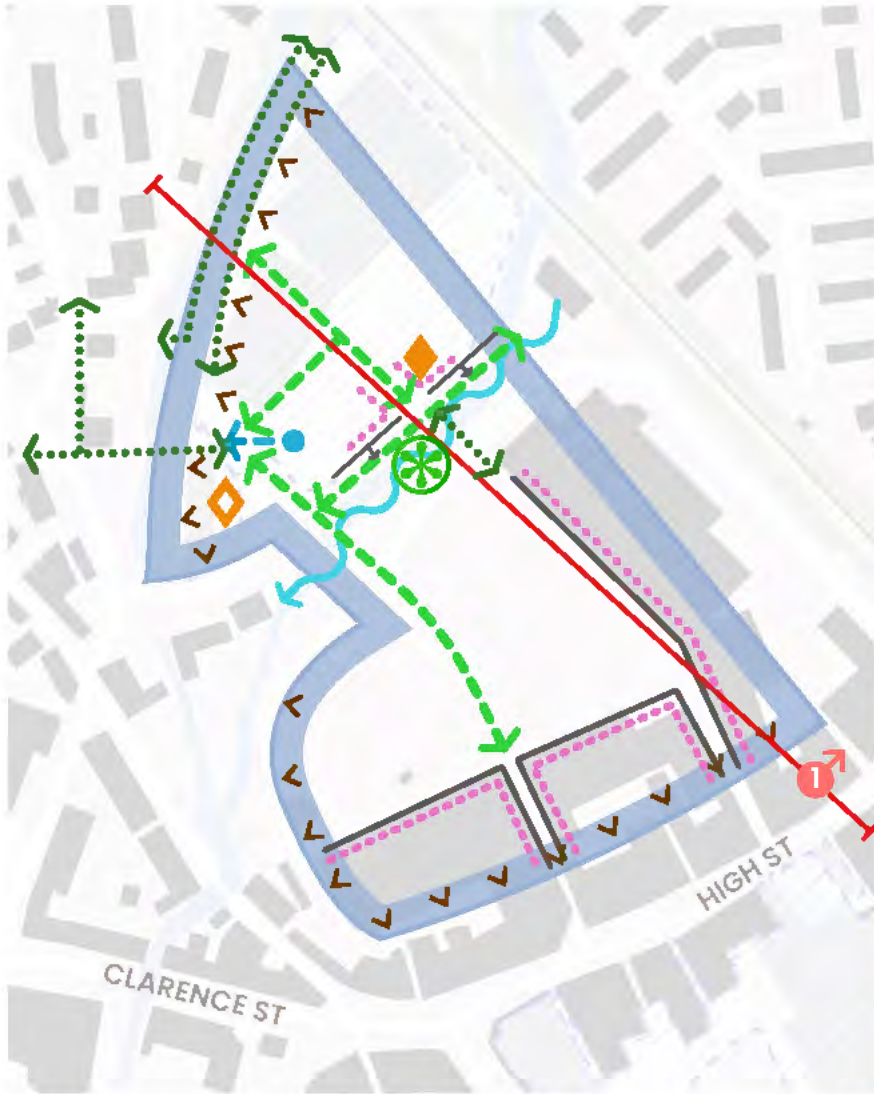

- Section location
- Allocated site in Local Plan
- THE STREET & GROUND FLOOR**
- Building Line
- New Active Frontage
- Retail / Flexible Commercial Ground Floor
- Key Overlooking Location
- Existing path or active travel street to connect to
- New active travel street connection
- SCALE & MASSING**
- Sensitive Edge
- OPEN SPACES**
- New green open space
- River restoration opportunity
- DETAIL & RICHNESS**
- Marker Building
- Landmark Building

TRANSITIONAL EDGES PLAN

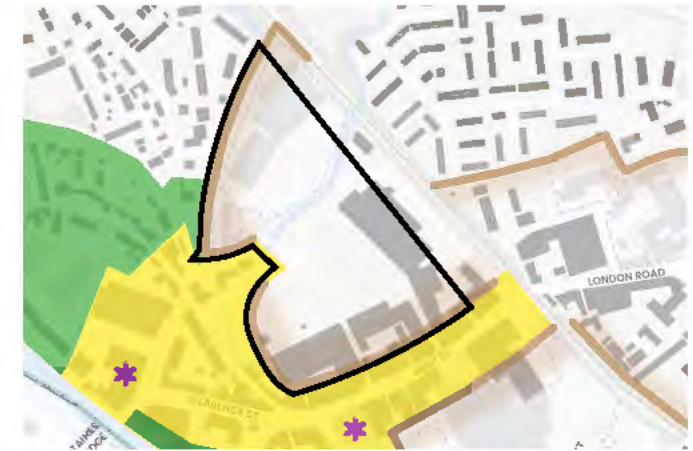

Transitional Edge, where heights step down to blend with prevailing built form and preserve street scale.

See Section 1 on following page for explanation and key principles on transitional edges.

(5.1.6.1b) HEIGHTS AND SCALE PRINCIPLES

This diagram illustrates overall principles for the scale and **massing** in the Two Rivers area. For section location see Area Type Coding Plan.

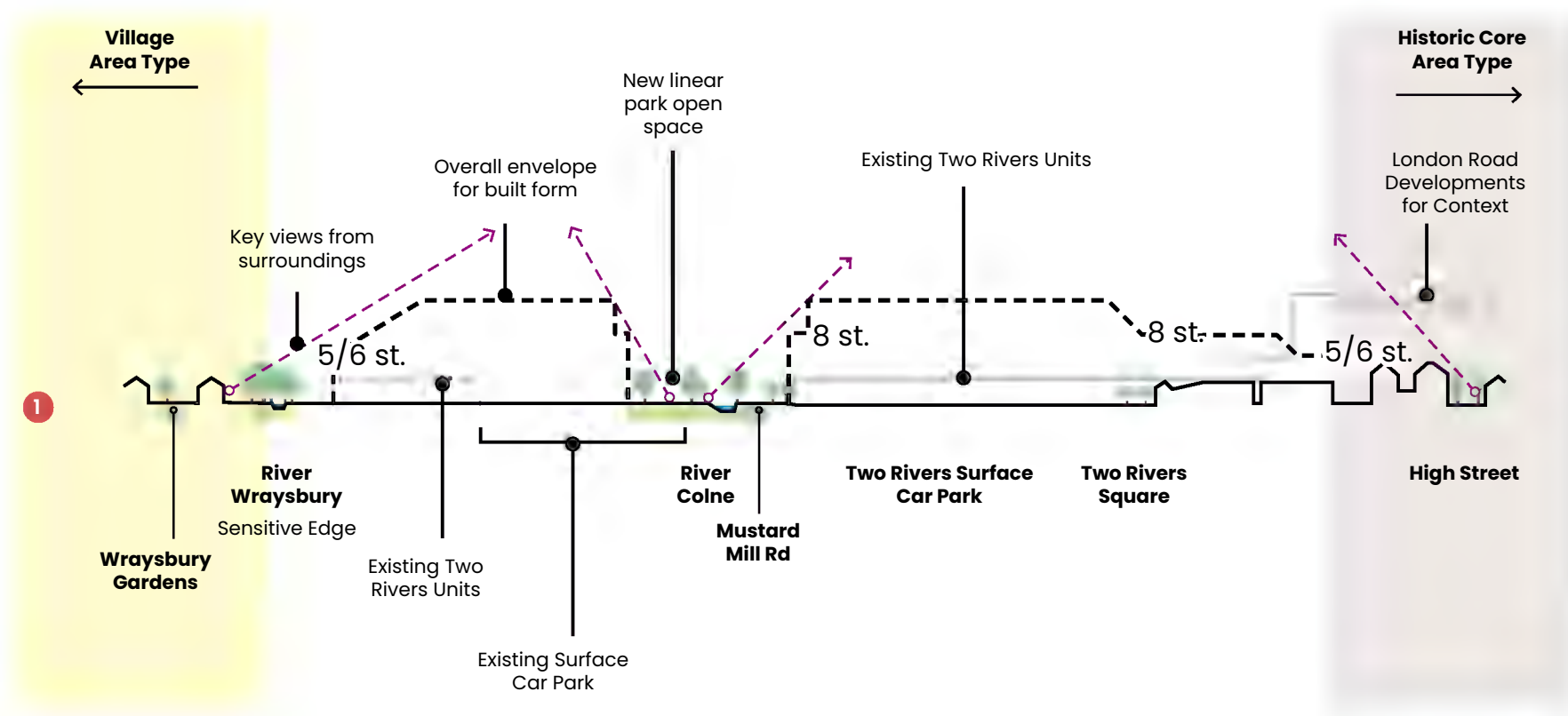

Key principles for **massing** are that development **must**:

- Step down towards the neighbouring residential area to the northwest, with heights at the edge approximately as high as the existing tree belt on the River Wraysbury (~15-18m, 5-6 storeys)
- Have heights of up to 8 storeys (approx 24m) immediately adjacent to the new linear park, with taller heights set back with a **'shoulder'**

5.1.6.1e KEY OPEN SPACE REQUIREMENTS

Proposals for a new open space **must** include:

1. Connections across existing bridges to town centre streets into open space and towards the north and west
2. Crossing point to provide walking and cycling access to open space
3. Overlooked, activated public realm at node
4. **Marker building** to terminate view from town centre
5. Retail **active frontage** around key node and overlooking of open space from built form
6. Strengthening of existing trees and planting to create varying landscape character
Accessible green open space around river
7. Walking and cycling links through open space

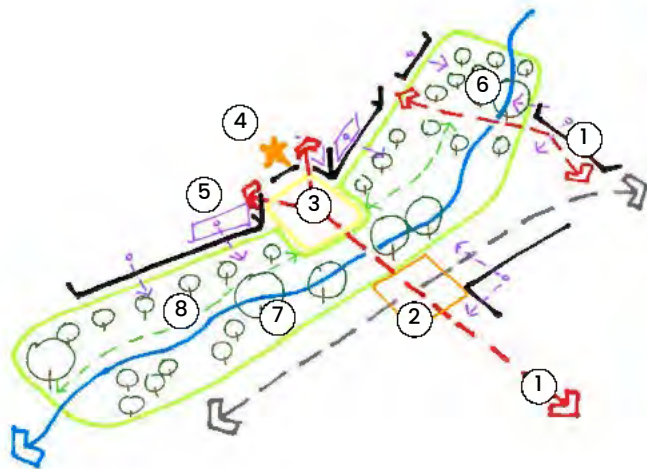

Illustrative approach to applying the key design requirements

EXAMPLES AND PRECEDENTS

Development in this area **could** implement the following design features, character and opportunities.



Views maintained through development to provide a visual connection to surrounding areas and natural spaces.



Using the design and materiality of bridges as important connection points and features.



Use varied and attractive landscape and public realm features to make use of the River Colne as the heart of a new open space, reactivating this area for both nature and people.

5.1.7 Elmsleigh: A Bustling Town Centre Neighbourhood for all



DESIGN AIMS

New development in the Elmsleigh area will create a new, integrated mixed-use town centre neighbourhood, progressively changing the existing monolithic, inward-facing built form to one of streets, open spaces and individual buildings, with much better connections to the river frontage and surrounding neighbourhoods and facilities.

Existing Context & Place Identity

The area to the south-east of the High Street is a covered 1970s shopping centre with a large multi-storey car park and service entrances on main streets. It is a part of the town's retail offer.

This part of the town centre is also an important gateway for public transport users, arriving by rail or bus, and for those walking or cycling, as the majority of homes in Staines-upon-Thames located within walking or cycling distance of the town centre are located to the south-east.

5.1.7.1 DESIGN REQUIREMENTS

General requirements for the **Town Centre Neighbourhoods Area Type** (see 4.2) apply. Development in this area type **must** comply with the following additional design requirements.

Where design requirements have a spatial requirement (e.g. location of key frontages) these are set out on the Area Type coding plan on the following page.

5.1.7.1a The Street & Ground Floor

- New street layouts designed on 'superblock' principles to prioritise active travel, with vehicle movement limited to parking and service access to buildings. South Street to become a multi-modal street (see 4.2.1.3).
- Retain existing NW-SE High St to bus station connection as a pedestrian priority street
- Retention and extension of existing retail, leisure and other commercial uses along key NW-SE axis, connecting to High Street and bus station. See Area Type Coding Plan
- Mix of retail and commercial unit sizes to provide opportunities for smaller and independent businesses
- Create new NE-SW pedestrian priority connection towards river frontage
- **Active frontage** onto South Street and bus station

5.1.7.1b Scale & Massing

- Heights to transition to surrounding built form as set out on the transitional edges plan and key principles in Section 1 on following pages
- **Massing** led by creating a comfortable street scale with the tightest width:height ratio of around 1:1. Heights that would break this street aspect ratio are permitted through the use of

a '**shoulder**' where heights step back from the street edge.

- General presumption of high residential densities and high **Floor Area Ratio** of 3.0 and above.
- Appropriate development typologies include podiums and towers, villas and linear blocks closer to edges.

5.1.7.1c Open Spaces

- New green open space at heart of new neighbourhood, where streets cross. Requirements are set out under 'Key Open Space Requirements' on following page.

5.1.7.1d Homes & Practicalities

- Retain existing public car parking provision within consolidated deck structures, with attractive façades or sleeved by other development

5.1.7.1e Detail & Richness

- Roofs of taller buildings should provide visual interest with distinctive form, and with variation when viewed from a distance.
- **Marker buildings** at key locations to provide legibility and townscape interest, reflecting principles set out under 4.2.5.2. See Area Type Coding Plan.

AREA TYPE CODING PLAN

This plan sets out where design requirements apply within this Area Type.

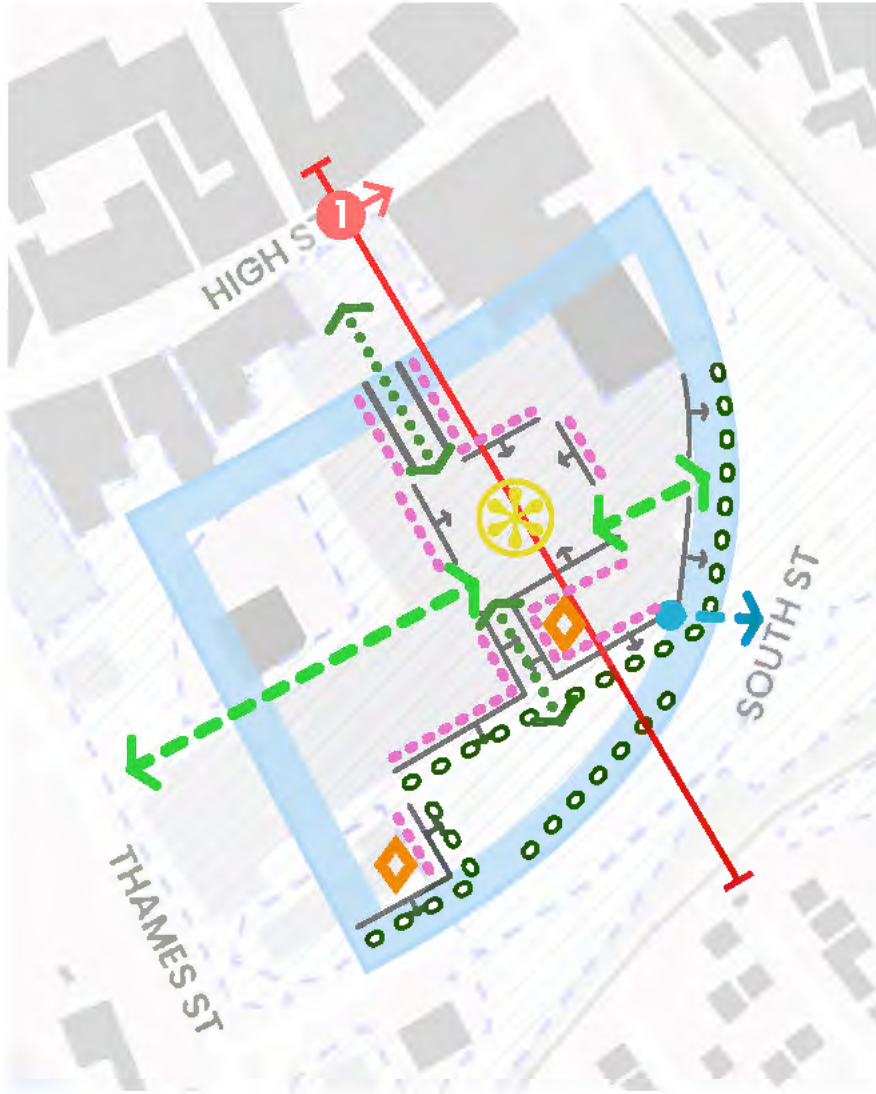

Section location

Allocated site in Local Plan

THE STREET & GROUND FLOOR

Building Line

New Active Frontage

Retail / Flexible Commercial Ground Floor

Key Overlooking Location

Existing path or active travel street to connect to

New active travel street connection

OPEN SPACES

New open space/ public realm

Street Planting & Greening

DETAIL & RICHNESS

Marker Building

TRANSITIONAL EDGES PLAN



Transitional Edge, where heights step down to blend with prevailing built form and preserve street scale.

See Section 1 on following page for explanation and key principles on transitional edges.

(5.1.7.1b) HEIGHTS AND SCALE PRINCIPLES

This diagram illustrates overall principles for the scale and **massing** in the Elmsleigh area.

For section location see Area Type Coding Plan.

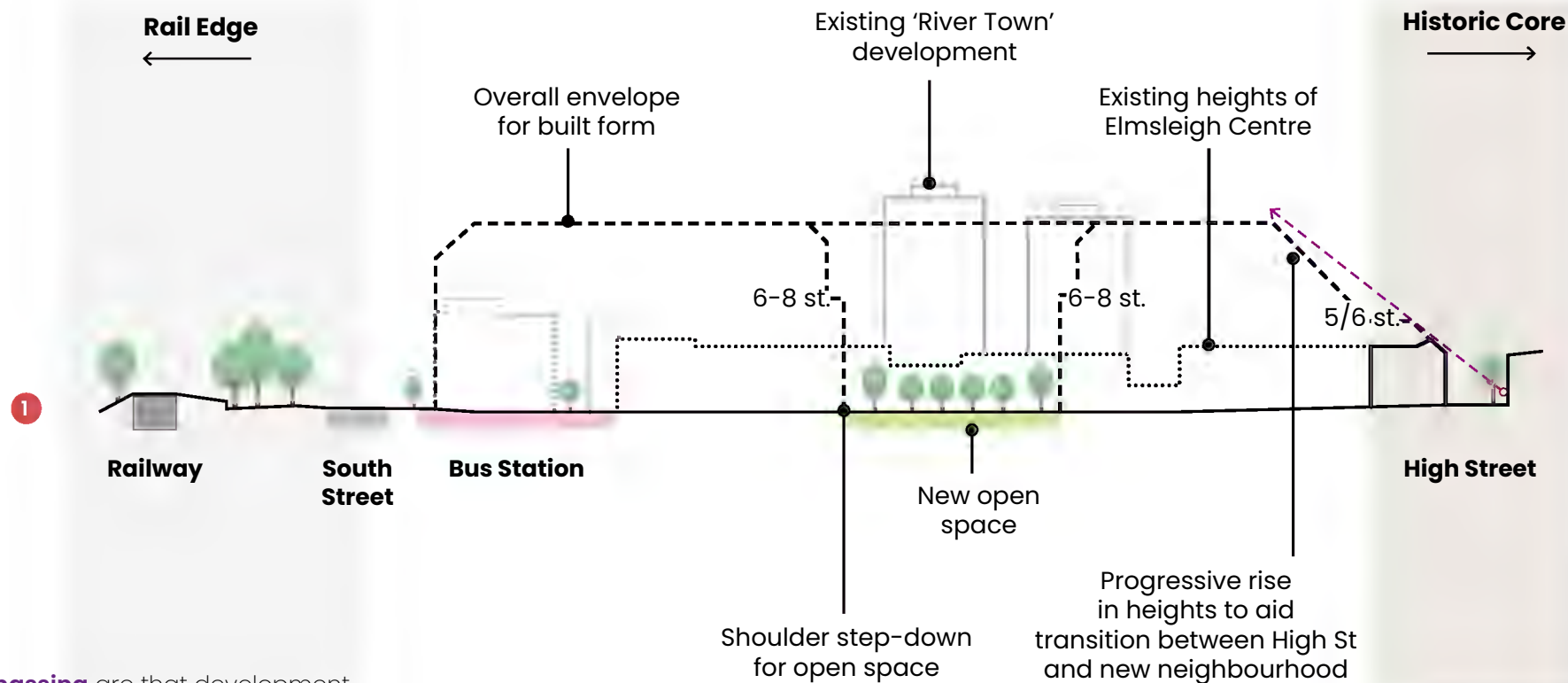

Key principles for **massing** are that development **must**:

- Step down towards the permitted heights in the High Street (5-6 storeys, approx 18m)
- Ensure that views from street level in the High Street are not interrupted by new built form in the Elmsleigh Area
- Have a podium or base facade of up to 8 storeys (approx 24m) surrounding any new public open spaces, with taller buildings set back above a **shoulder**

5.1.7.1f KEY OPEN SPACE REQUIREMENTS

Proposals for a new open space **must** include:

1. Key connections to High Street, Bus Station and Memorial Gardens
2. Potential secondary connection to the northeast
3. Green open space or new public realm with trees and planting
4. Retail **active frontages** facing space with associated 'spill-out' public realm
5. Built form to create active edge along southwestern frontage
6. Tree-lined, overlooked connection towards the river and Memorial Gardens

EXAMPLES AND PRECEDENTS

Development in this area **could** implement the following design features, character and opportunities.



Variety in materials, architecture and street planting to provide variation while maintaining fine grain, human-scale streets.



Creation of an open space with a distinct urban character, variety of spaces and uses within.

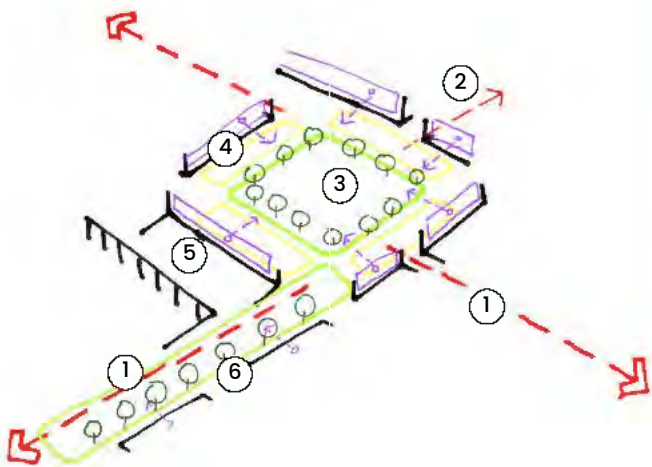

Illustrative approach to applying the key design requirements



Use of patterns, materials and detailing in the public realm to create attractive pedestrian-priority streets that lead people through the neighbourhood.

5.1.8 Railway Edges: Improving the Quality of Streets and Spaces



DESIGN AIMS

New development in these locations will ensure that noise levels and quality of spaces next to the railway line are acceptable for residents. They should create good quality street environments and ensure that any existing or new connection points across the railways are safe, overlooked and become part of the wider street network.

Existing Context & Place Identity

Two busy railway lines divide Staines-upon-Thames town centre from its surrounding suburbs. On the river/town centre side of these lines are a series of car parks and other areas where new development is proposed. There is little existing built form but on the other side of the railway lines are primarily existing suburbs.

5.1.8.1 DESIGN REQUIREMENTS

General requirements for the **Town Centre Neighbourhoods Area Type** (see 4.2) apply. Development in this area type **must** comply with the following additional design requirements.

Where design requirements have a spatial requirement (e.g. location of key frontages) these are set out on the Area Type coding plan on the following page.

5.1.8.1a The Street & Ground Floor

- Create a strong street edge with a podium or continuous base building to limit impact of railway on wider town centre neighbourhoods. See following pages for principles.
- Safeguard potential new bridge or tunnel link across Egham railway tracks towards railway station. See Area Type Coding Plan.
- Incorporate new street trees and planting along main roads, particularly South St to aid transformation to multi-modal street.

5.1.8.1b Scale & Massing

- Heights to transition to surrounding built form as set out on the transitional edges plan
- **Massing** led by creating a comfortable street scale with the tightest width:height ratio of around 1:1. Heights that would break this street aspect ratio are permitted through the use of a **'shoulder'** where heights step back from the street edge.
- General presumption of high residential densities and high **Floor Area Ratio** of 3.0 and above, particularly close to major roads such as South St.

5.1.8.1c Open Spaces

- Create a gateway space at edge of Elmsleigh neighbourhood. Requirements are set out under 'Key Open Space Requirements' on following page.

5.1.8.1d Homes & Practicalities

- Retain existing public car parking provision within consolidated deck structures, with attractive façades or sleeved by other development

5.1.8.1e Detail & Richness

- Roofs of taller buildings should provide visual interest with distinctive form, and with variation when viewed from a distance.
- **Marker buildings** at key locations to provide legibility and townscape interest, reflecting principles set out under **4.2.5.2**. See Area Type Coding Plan

AREA TYPE CODING PLAN

This plan sets out where design requirements apply within this Area Type.

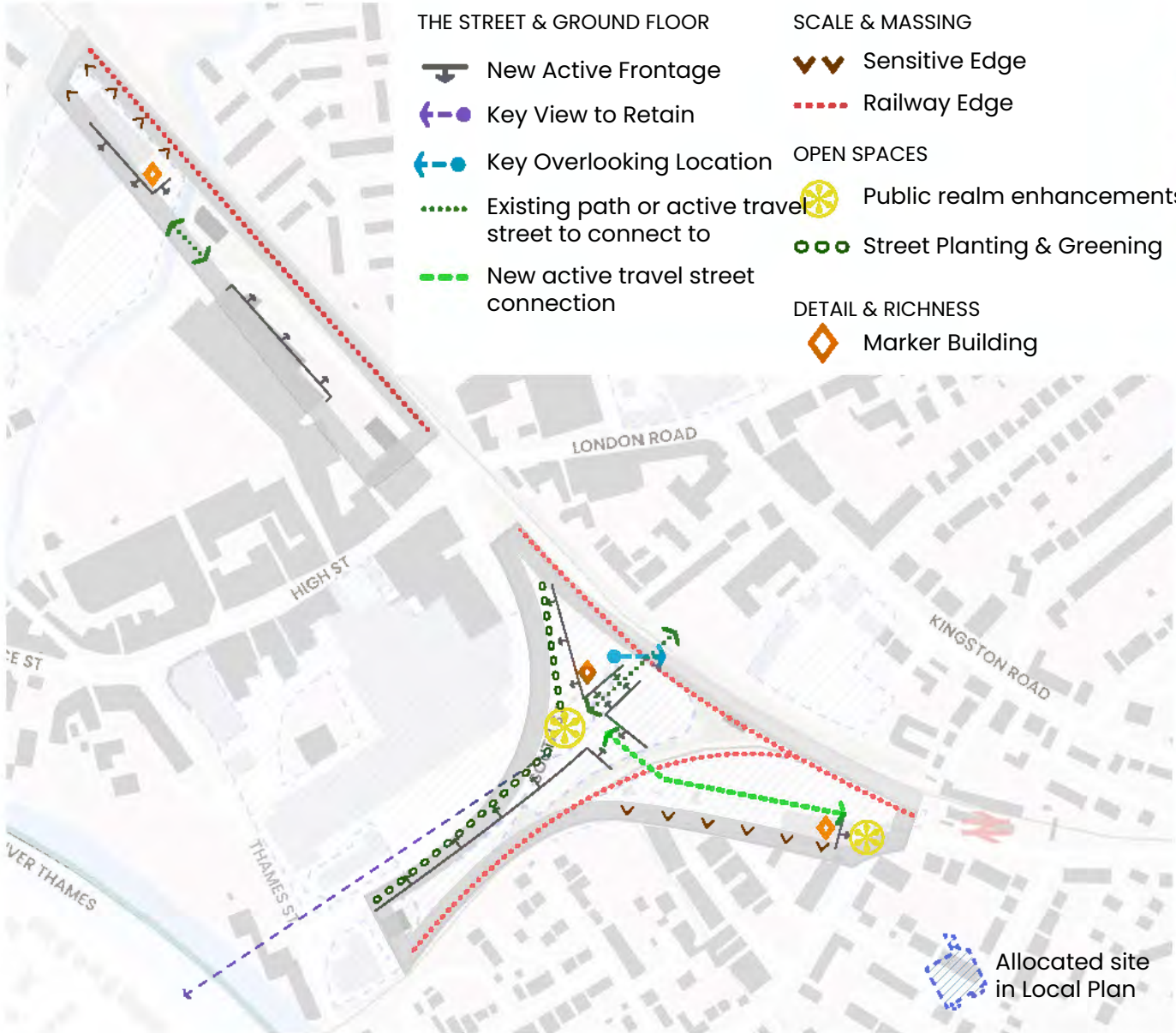

TRANSITIONAL EDGES PLAN



Transitional Edge, where heights step down to blend with prevailing built form and preserve street scale.

5.1.8.1f RESPONDING TO A RAILWAY LINE

This diagram sets out overall principles and an illustrative example for arranging built form along a railway edge.

Key principles for **massing** are that development **must**:

- Have a continuous podium, plinth or base building along the street edge that provides good enclosure and **active frontage** to the street
- Arrange taller **massing** above this in a way that provides residents with a variety of views to both town centre and across surrounding areas and the railway lines

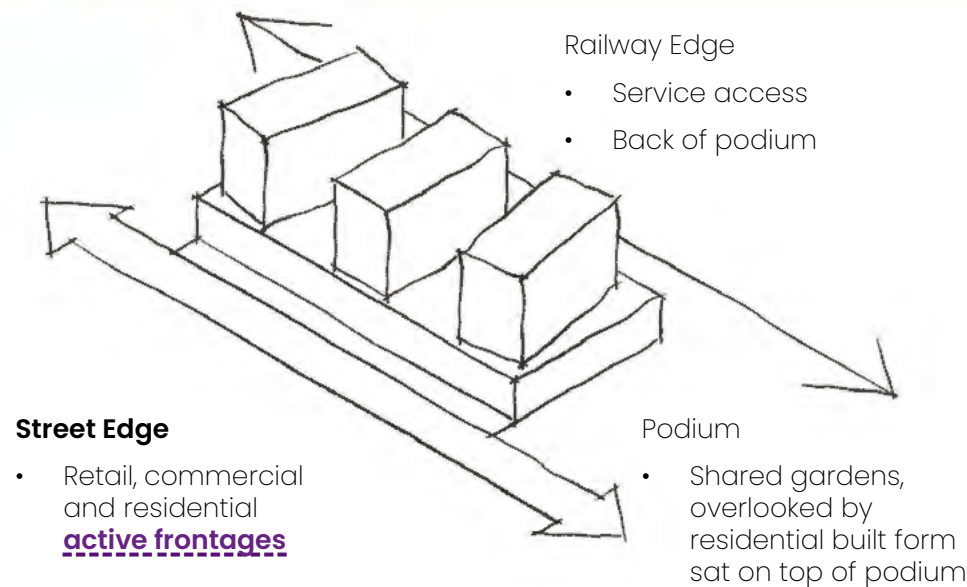

CREATING A STREET EDGE

This diagram sets out overall principles for how the use of a base podium with **active frontage** can create an attractive street environment, vertical integration of different uses, and how **massing** should relate to the street and the railway lines.

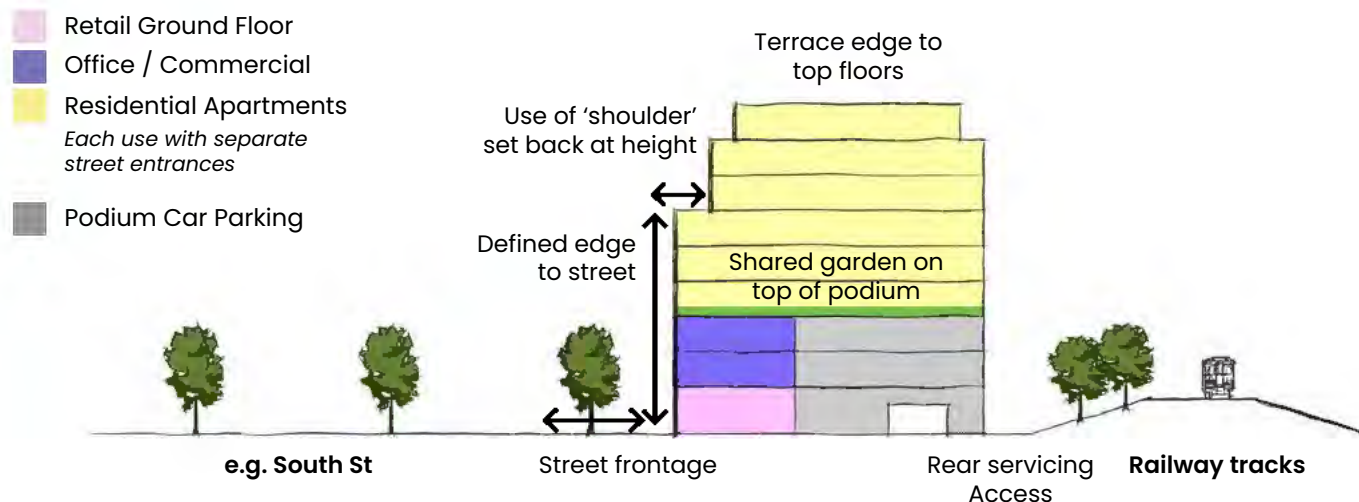

5.1.8.1g KEY OPEN SPACE REQUIREMENTS

Proposals for a new open space **must** include:

1. Connection to Station Path through underpass, with improved overlooking and attractive green space environment
2. Improved crossing point and public realm for walking and cycling
3. Built form to overlook streets and public realm
4. Retail and activated frontage facing towards bus station and railway station connection, with associated 'spill out' public realm
5. Street tree planting and progressive change of South Street to a 'boulevard'
6. Consideration of potential future connection across railway tracks to the southeast

EXAMPLES AND PRECEDENTS

Development in this area **could** implement the following design features, character and opportunities.



Rear/railway side to provide quality amenity space for residents through changes in levels.



Multi-storey car parks with facade treatments, ideally located above active commercial ground floors.

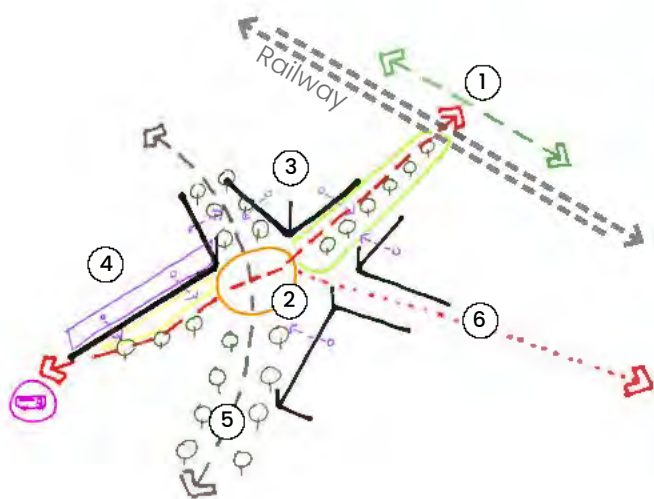

Illustrative approach to applying the key design requirements



Activated street edge with balconies and more distinctive built form to mark corners.

5.2 Sunbury Cross

OVERVIEW

This section sets out further Design Requirements and guidance for development in Sunbury Cross town centre.

EXTENT AND CONTEXT



-  High Streets
-  Town Centre Neighbourhoods
-  Suburban
-  Business Park
-  Light Industrial
-  Retail Park

 Area of Change Boundary

DEVELOPMENT CONTEXT

Sunbury Cross could see significant change in coming years. The [Local Plan](#) allocates around 1,000 new homes to be built, mostly at higher densities and resulting [floor area ratios](#) than the prevailing built form, and on sites that are poorly connected within a challenging location.

Some new homes will be on sites that are currently undeveloped and others will be redevelopment sites. The Design Code sets out the requirements for all these areas, and also sets out a vision of how to transform the area over time.



The varied existing context of low and high-rise development in Sunbury Cross

DESIGN AIMS

New development in Sunbury Cross town centre **will**:

- Create connections between areas of new development and the core of Sunbury Cross
- Improve the road safety and personal security of the public realm and streets
- Reduce severance created by infrastructure
- Link the railway station to the main shopping area
- Create a more human-scale place and street environment
- Create much-needed green open spaces for residents and the community



Find out more background information about the borough in Appendix A 'Understanding Spelthorne Today'.



Personal and road safety, noise, air quality and quality of life are priorities for the community in Sunbury Cross.

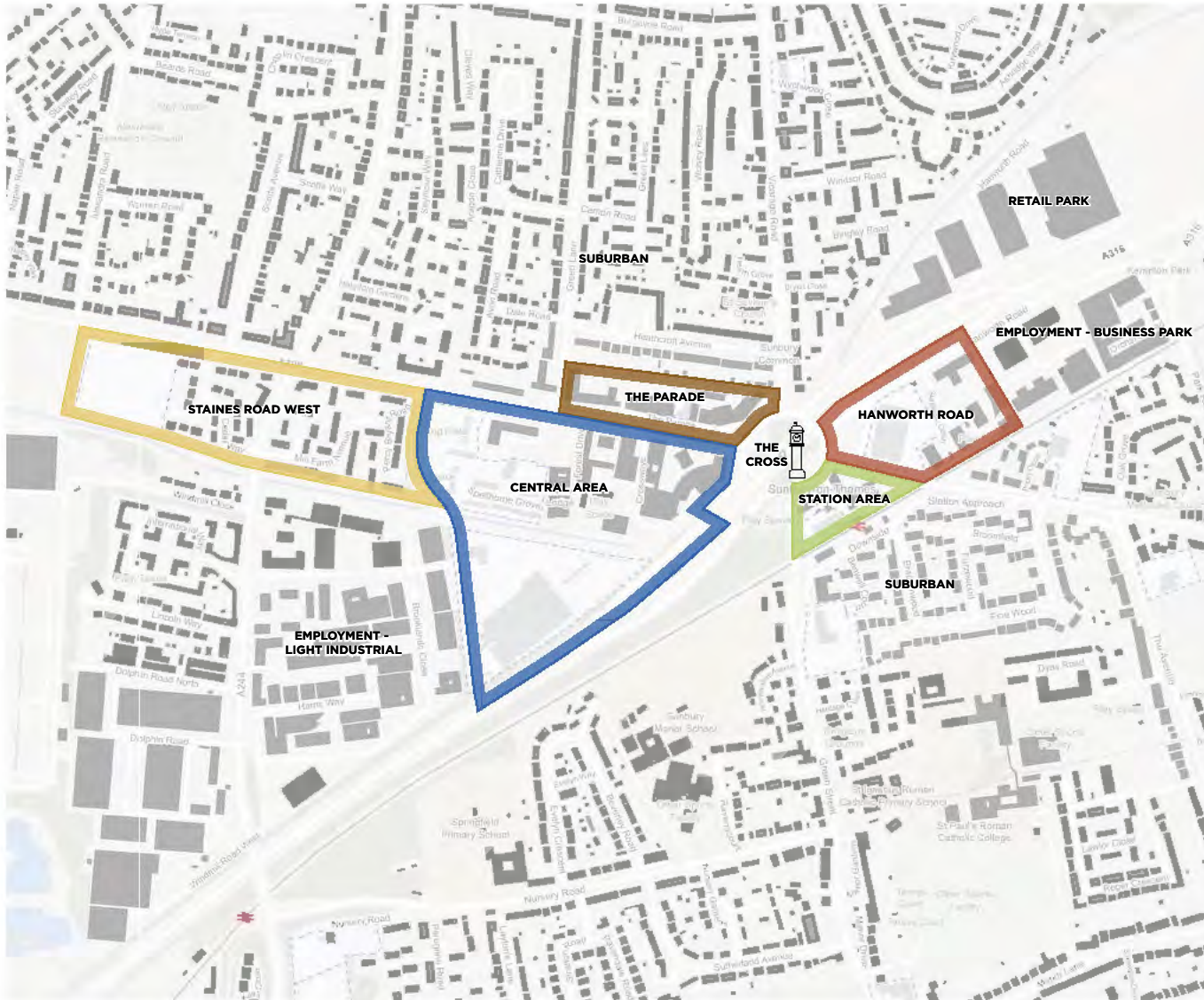

Area Types





Within the Area of Change, more detailed requirements are set out by finer-grain Area Types. Each Area Type in the town centre is considered by whether it will largely retain its existing character and contribution to overall place identity, or whether it is likely to change substantially in character.

Incremental Change

Retaining existing character and place identity. Design requirements strongly reflect context.

- 
THE PARADE
 General requirements for the High Street Area Type (see 4.1) apply.
 - 
STAINES ROAD WEST
 General requirements for Suburban Area Type (see 4.4) apply.

 - 
STATION AREA
 - 
HANWORTH ROAD
 - 
CENTRAL AREA
- General requirements for the Town Centre Neighbourhoods Area Type (see 4.2) apply.

Transformative Change

Defining a new character and place identity. Design requirements set key parameters only.



THE CROSS

The Cross itself, now the M3 junction, lies mostly outside of the scope of the Design Code. Principles for change are set out in the Spatial Vision on the following pages.

A FUTURE VISION FOR SUNBURY CROSS

Sunbury Cross is a place negatively impacted by a complex mix of major roads, railways and water supply infrastructure. It was transformed in the late 1960s and early 1970s by the M3 motorway and grade-separated junction, which continues to detract from its quality as a place, and causes severance, noise, safety and air quality issues.

Sunbury Cross can be more than a motorway junction with hard edges, railway and road severance, aqueduct edges, wedges of land, a retail mall and section of frontage shops and disconnected residential neighbourhoods. The spatial vision sets out the possibilities that could be pursued through wider work with multiple planning, highway and transport authorities as well as individual schemes.

The Design Code explores how new development can help to make this happen through incremental change. Major change at Sunbury Cross requires further work and co-ordination amongst all parties to move towards a transformative masterplan.

The vision's key aims are:

- Connect existing and new neighbourhoods with each other and creating a sense of place
- Reuniting East and West Staines Road
- Connect the centre with the railway station
- Create new green spaces and links

Many of the key changes at Sunbury Cross will be beyond the scope of individual applications, requiring wider co-ordination on changes to infrastructure. Designs **should** respond to the potential for change in the future and make appropriate provision.

Concept



Re-imagining how people could move through Sunbury Cross, with lighting, artwork, planting and surface street crossings



Key Themes and Projects

Short Term

- Linking the centre and the station

Medium Term

- Transforming Staines Road West
- New links between neighbourhoods
- Human-scale built form
- New green spaces and networks

Long Term

- M3 junction reconfiguration

Short Term

Linking the centre and the station



Top: Phoenix Flowers, M8, Glasgow (7N Architects)

Bottom: Toronto Gardiner Freeway Park

Providing an attractive, safe and clear surface route through existing space under the M3 would improve the ease of walking and cycling movement for all between Sunbury Common / the centre and Lower Sunbury / the station. This can be accomplished through the use of artwork, improved lighting, activated useful spaces and passive surveillance from surrounding built form.

Medium Term

Transforming Staines Road West



Exchange St 'Grey-to-Green' transformation, Sheffield

Staines Road West is currently a major dual carriageway and a barrier for moving between shops and neighbourhoods. New green infrastructure, public realm changes and a transformation to a 'boulevard'-style environment would create a healthier, more attractive street environment.

Medium Term

New green spaces and networks



Mayfield Park, Manchester

The Staines Aqueduct is a major piece of infrastructure severing links between neighbourhoods. Although access to the aqueduct may need to remain restricted, it could form the basis of a future green network linking neighbourhoods together and contributing to a greener, healthier Sunbury Cross.

Long Term

M3 junction reconfiguration



Masshouse Circus transformation to Masshouse Plaza, Birmingham

The M3 junction and flyover dominate Sunbury Cross today. Long-term, this should change, following precedent from other cities across the world who have successfully reconsidered the need for urban motorways

5.2.1 The Parade: The Historic Link to the Past in Sunbury Cross



DESIGN AIMS

New development in this area **will** respond to the strong existing building line and low-rise built form, with some intensification along Staines Road West.

Existing Context & Place Identity

The Parade, a row of shops and commercial buildings, is one of the few areas of Sunbury Cross that retains its more traditional built form. To the north it borders a largely post-war suburban area, and it thus forms an important transitional area from the Centre to the south.

5.2.1.1 DESIGN REQUIREMENTS

General requirements for the **High Streets Area Type** (see 4.1) apply. Development in this area type **must** comply with the following additional design requirements.

5.2.1.1a Building Heights

- Heights of up to 5 storeys (approx 15m) in compliance with maximum heights plan

5.2.1.1b Building Line

- Match existing building line along Staines Road West

5.2.1.1c Building Grain

- Typical building frontage grain of 6–10m

5.2.1.1d Vertical Mix of Uses

- Ground floor commercial space
- Apartments located above ground floor uses

5.2.1.1e Public Realm

- Incorporate new street trees and planting along Staines Road West
- Future-proof designs for potential removal of frontage service access road
- Rear parking courts overlooked by built form
- Minimise access points to rear parking courts through main frontage
- Entrances to dwellings from the street

5.2.1.1f Facades, Detail & Richness

- Pitched roofs facing the street or gable-end, to reflect adjacent buildings
- Windows on frontage to match surrounding rhythm and characteristics
- Materials and architectural detailing to respond to prevailing form

BUILDING HEIGHTS PLAN



Heights typically up to:

5 storeys (approx 15m)

Building heights are measured from pavement level to the roofline.

Typical storey heights for different uses are:

- Residential: 3m
- Commercial / Office: 4m
- Ground Floor Retail / Commercial: 4.5m

5.2.2 Staines Road West: Connecting new Development to the Surroundings



DESIGN AIMS

New development in this area will front onto Staines Road West and address the Sports Club fields to the west. Intensification of densities and built form over the prevailing area is supported, provided there is a transition in built form to existing areas within and adjacent to the area.

Existing Context & Place Identity

This area type runs between Staines Road West and the Staines Aqueduct. It contains two low-rise cul-de-sac style developments divided by Windmill Road, and the eastern boundary is an inactive frontage onto Escot Road.

5.2.2.1 DESIGN REQUIREMENTS

General requirements for the **Suburban Area Type** (see 4.4) apply. Development in this area type **must** comply with the following additional design requirements.

5.2.2.1a Edges

- **Active frontage** facing onto Staines Road West following 'Dual Carriageways, Urban Road' edge type (see 4.4.1.2e)
- **Active frontage** overlooking sports field to the west following 'Open Spaces' edge type (see 4.4.1.2b)
- **Active frontage** facing aqueduct to south, following 'Watercourses' edge type (see 4.4.1.2c)
- Built form on allocated site backing onto existing residential gardens to the west following 'Residential, Backing Onto' edge type (see 4.4.1.2g)

5.2.2.1b Streets

- New streets to comply with street types set out under 'New Residential Neighbourhoods' (see 4.4.1.3)
- Continuous grid of new streets within allocated site, no use of cul-de-sacs
- Connections from new development to existing streets and cul-de-sacs

5.2.2.1c Open Spaces

- At least one new open space within allocated site, amongst homes
- Potential for new open space adjacent to aqueduct at southern edge of allocated site

5.2.2.1d Built Form

- Heights to comply with the maximum heights plan
- Observe building line on Staines Road West
- Pitched roofs on all buildings

BUILDING HEIGHTS PLAN



Heights typically up to:

■ 3-4 storeys (approx 12m)

■ 6 storeys (approx 18m)

Building heights are measured from pavement level to the roofline.

5.2.3 Station Area: Improved links to public transport



DESIGN AIMS

New development in this area will enable better accessibility of the station for pedestrians and cyclists, provide frontage to surrounding roads, and create a more consistent built form. Significant intensification is possible here in the context of the railway station as an important public transport link.

Existing Context & Place Identity

The area around Sunbury Station is a small pocket of development cut off from its surroundings by the M3, railway line and the feeder roads to Sunbury Cross roundabout. Land uses are largely commercial with no consistent architectural style, building line or grain.

5.2.3.1 DESIGN REQUIREMENTS

General requirements for the **Town Centre Neighbourhoods Area Type** (see 4.2) apply. Development in this area type **must** comply with the following additional design requirements.

5.2.3.1a The Street & Ground Floor

- Provide walking and cycling access to the station from Green Street and Staines Road East.
- No on-street and frontage parking on Station Road to make it a safer, more welcoming space for walking and cycling.
- Limit the number of vehicle accesses across footways from Station Road.
- Provide more pedestrian public realm along Station Road
- A consistent building line on Station Road with no 'leftover' spaces
- Incorporate new street trees and planting along Station Road
- **Active frontages** and passive surveillance facing Green Street and Staines Road East

5.2.3.1b Scale & Massing

- Heights to transition to surrounding built form as set out on the transitional edges plan
- Grain of Station Road frontage 6–10m wide

5.2.3.1c Detail & Richness

- Roofs of taller buildings should provide visual interest with distinctive form, and with variation when viewed from a distance.

TRANSITIONAL EDGES PLAN



Transitional Edge, where heights step down to blend with prevailing built form and preserve street scale.

Gateway Edge, where heights step up to meet The Cross or provide an edge to the M3

5.2.4 Hanworth Road: Changing uses and the quality of spaces around



DESIGN AIMS

New development in this area will improve connections to the rest of Sunbury, and create more attractive and inspiring places for people to live. High-density development fronting onto the roundabout will make efficient use of land in a well-connected location.

Existing Context & Place Identity

The area to the north of Staines Road East is bounded by the railway line and the M3. Early 2000s apartment buildings and other coarse-grain development is changing the use of a former commercial and industrial area, but the area is severed from the surroundings by major infrastructure, and is dominated by surface car parking.

5.2.4.1 DESIGN REQUIREMENTS

General requirements for the **Town Centre Neighbourhoods Area Type** (see 4.2) apply. Development in this area type **must** comply with the following additional design requirements.

5.2.4.1a The Street & Ground Floor

- **Active frontage** to face Staines Road East
- **Active frontage** to face Hanworth Road
- Planting and street trees on Staines Road East and Hanworth Road
- Direct pedestrian access from new development to Sunbury Cross roundabout

5.2.4.1b Scale & Massing

- Heights to transition to surrounding built form as set out on the transitional edges plan, with heights greatest near the roundabout
- Building typologies of linear block, villas and podiums with towers

5.2.4.1c Open Spaces

- Open space to be screened from the M3 and Sunbury Cross roundabout by interposed built form

5.2.4.1d Homes & Practicalities

- Podium or shared rear courtyard car parking, accessed from Hanworth Road

5.2.4.1e Detail & Richness

- Roofs of taller buildings should provide visual interest with distinctive form, and with variation when viewed from a distance.

TRANSITIONAL EDGES PLAN



Transitional Edge, where heights step down to blend with prevailing built form and preserve street scale.

Gateway Edge, where heights step up to meet The Cross or provide an edge to the M3

5.2.5 Central Area: New and Renewed Connected Neighbourhoods



DESIGN AIMS

New development in this area will create new connections, improve place quality, passive surveillance and road safety of the public realm. It will create a more human-scale place with fewer opportunities for crime or unused leftover space. New homes will have access to safe green open spaces on their doorsteps.

Existing Context & Place Identity

The Central Area of Sunbury Cross contains a wide mix of uses and built form, with a number of taller towers and a poor, car-dominated and broken-up street environment. To the northeast, the shopping centre is designed for access by car and turns its back on surrounding streets. To the south, a large supermarket sits within surface parking and with poor, pedestrian accessibility that feels unsafe. In the northwest, a number of residential developments are bounded by infrastructure and lack connectivity and quality open space.

5.2.5.1 DESIGN REQUIREMENTS

General requirements for the **Town Centre Neighbourhoods Area Type** (see 4.2) apply. Development in this area type **must** comply with the following additional design requirements.

Where design requirements have a spatial requirement (e.g. location of key frontages) these are set out on the Area Type coding plan on the following page.

5.2.5.1a The Street & Ground Floor

- Street trees on Staines Road West
- New development to provide active frontages and passive surveillance along all streets, particularly at locations highlighted on plan
- Repair building line along Staines Road West (see diagram below)

5.2.5.1b Scale & Massing

- Heights to transition to surrounding built form as set out on the transitional edges plan, with heights greatest near the roundabout and M3
- Building typologies of linear block, villas and podiums with towers

5.2.5.1c Open Spaces

- Relocate existing open space in Spelthorne Grove to be surrounded and overlooked by built form, providing public pedestrian link through to supermarket
- Small overlooked green open space to provide connection from supermarket to shopping centre

5.2.5.1d Detail & Richness

- Use marker buildings to terminate views as noted on plan and provide legibility
- Roofs of taller buildings should provide visual interest with distinctive form, and with variation when viewed from a distance.



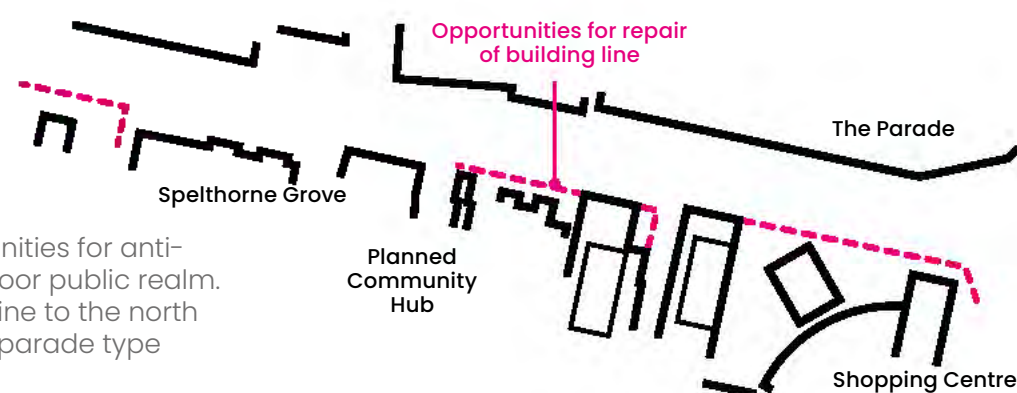





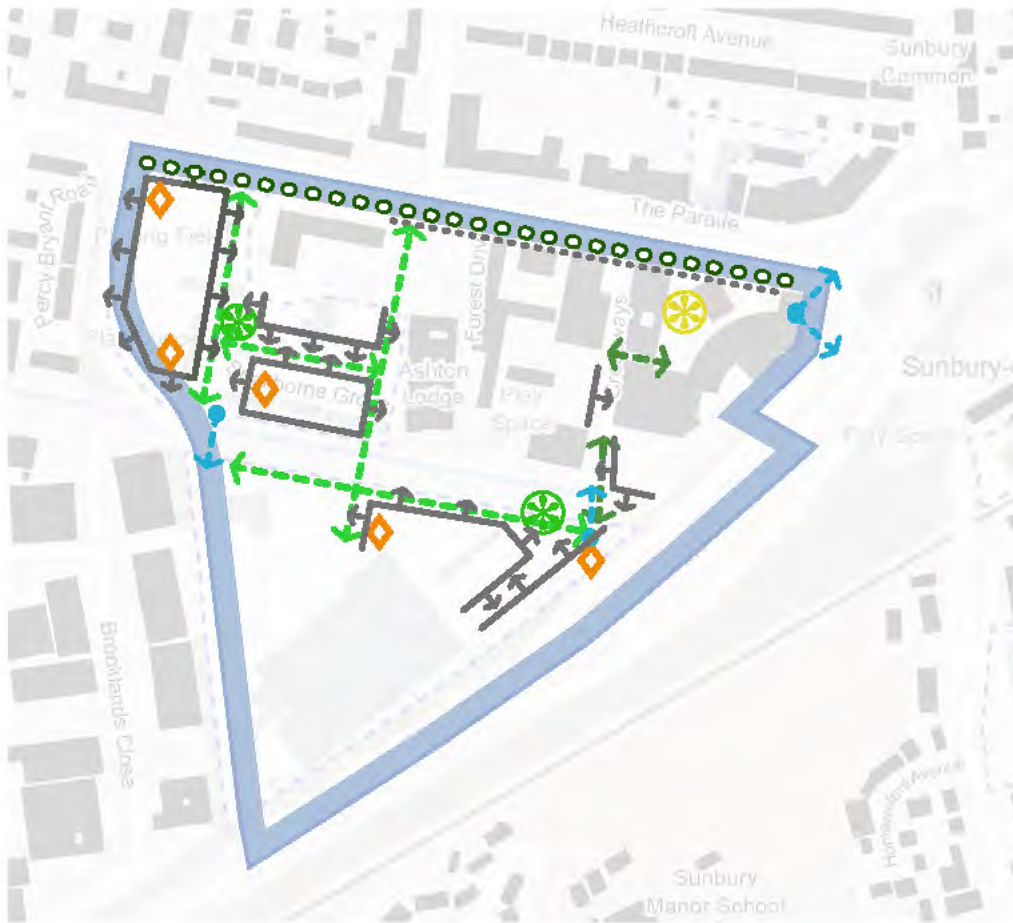

Comparison of existing building lines on Staines Road West. To the south, a broken-up building line creates spaces that lack passive surveillance or are unused 'leftover' spaces, creating opportunities for anti-social behaviour and a poor public realm. The continuous building line to the north creates a 'High Street' or parade type environment.



AREA TYPE CODING PLAN



This plan sets out where design requirements apply within this Area Type.



-  Allocated site in Local Plan
- THE STREET & GROUND FLOOR**
-  New Active Frontage
-  Repaired Building Line
-  Key Overlooking Location
-  Existing path or active travel street to connect to
-  New active travel street connection
- OPEN SPACES**
-  New green open space
-  Public realm enhancements
-  Street Planting & Greening
- DETAIL & RICHNESS**
-  Marker Building

TRANSITIONAL EDGES PLAN



-  Transitional Edge, where heights step down to blend with prevailing built form and preserve street scale.
-  Gateway Edge, where heights step up to meet The Cross or provide an edge to the M3



Preparing your Application

- » What you need to do now
- » How to get further help
- » **6.1 Submission Checklists**

What you need to do now

When submitting your planning application, you will need to demonstrate that you have complied with the necessary requirements set out in the Code. You will also need to demonstrate that you have followed an appropriate and comprehensive [design process](#).

To demonstrate compliance, you will need to submit:

- A completed copy of the relevant Design Code checklist for the Area Type your application falls within. These can be found at the end of this chapter.
- For major applications (i.e. 10 dwellings or more, or where the floorspace is 1000 sq. metres or more, or the site is 1ha or more) a Design and Access Statement which sets out the design process undertaken

DESIGN CODE CHECKLISTS

A Design Code Checklist must be completed for all applications, to self-assess compliance with the Code and to clearly signpost where information about compliance is held within the submitted application documents.

You should submit the relevant Area Type checklist with your application (e.g. Town Centre Neighbourhood), based on where your application is. In Inner Suburban or Suburban Area Types, you should submit the relevant checklist for your development type (e.g. Residential Extension or New Residential Neighbourhoods).

All Checklists can be found at the end of this Chapter, and are available for separate download on the Spelthorne Borough Council website.

DESIGN AND ACCESS STATEMENT

Design and Access Statements (DAS) are required for major applications, i.e. 10 dwellings or more, or where the floorspace is 1000 sq. metres or more, or the site is 1ha or more.

Through the Design and Access Statement applicants need to explain and justify the choices made which will achieve high quality outcomes by providing a contextual survey and analysis, showing how this has informed the design proposals.

The Design and Access Statement will vary in its detail and coverage depending on the type and scale of application. It could include the following, aligned to the Design Process set out in Chapter 2:

Step 1: Understanding The Site and Context

Plans and diagrams showing an understanding of the surrounding character, features, movement, planned change and other baseline information set out in Chapter 2. This should inform plans of site constraints and opportunities for the proposal and wider area.

Step 2: The Vision

An overview of what the proposal intends to achieve, with a narrative and key visualisations.

Step 3: Developing and Testing Options

An explanation of the design development taken as part of the proposal's design, including input and changes derived from community and stakeholder engagement.

Step 4: Site Parameters

For larger proposals, the key parameters and strategies for movement, green and blue infrastructure, sustainability, built form and land use that underly the detail proposals, and have been informed by the site analysis.

Step 5: Resolving the Details

Plans, elevations, visualisations, sections and other annotated technical diagrams that show clearly what is being proposed, to an appropriate level of detail.

How to get further help

Spelthorne Borough Council will support developers and applicants to deliver high-quality design and place-making, through a comprehensive design process that aims to deliver the outcomes set out in the Design Code.

The Council offers a number of services to help support the [design process](#).

PRE-APPLICATION SUPPORT

This is the starting point for all proposals. Come to us at an early stage to discuss your proposal, obtain feedback on your emerging scheme and how best to improve the design. We will be able to ensure that wider council teams are able to feed into early discussions to ensure integrated thinking and better design outcomes.

Although there is a cost to applicants, you will benefit from a better-quality application and a clearer route to the determination of your planning application. The iterative nature of design means that, particularly for larger applications, a number of pre-application reviews are advised as you progress your design proposals.

PLANNING PERFORMANCE AGREEMENTS (PPAS)

These are voluntary agreements between the applicant and the Spelthorne Council that set out the actions, resources and timescales for handling a particular planning application. They can be used to support good design through a continuous and iterative process of officer engagement across the council, and may include dedicated design workshops.

They can be used for any type of planning application but usually for large-scale, complex proposals. They can be used at any stage from early brief development through to conditions and reserved matters. Fees for PPAs depend on the size and complexity of the proposal.

DESIGN REVIEW

Design Review is an independent and impartial evaluation of proposals best undertaken at pre-application stage. It is a collaborative process, where constructive feedback can be given to improve the design quality of proposals.

Local Plan policy PS2 encourages Design Review to be undertaken for proposals that have significant impacts in relation to design or public interest.

FURTHER GUIDANCE AND RESOURCES

A wide range of further guidance has been published by other organisations addressing important aspects of design.

General Guidance

- [Secured by Design](#)
- [Active Design \(Sport England\)](#)
- [Building for a Healthy Life](#)
- [Surrey Historic Environment Record](#)

Climate Change & Sustainability

- [Spelthorne Climate Change SPD](#)
- [LETI Climate Emergency Design Guide](#)

Movement and Street Design

- [Surrey Healthy Streets Design Code](#)
- [Manual for Streets](#)
- [LTN 1/20 – Cycle Infrastructure Design](#)
- [CoMoUK – guidance on Mobility Hub design](#)
- [Network Rail Public Realm Design Guidance](#)

Green and Blue Infrastructure

- [Building with Nature](#)
- [Trees and Design Action Group – guidance on street trees](#)
- [National Standards for SuDS \(MHCLG\)](#)
- [Surrey Sustainable Drainage System Design Guidance](#)
- [Natural England Green Infrastructure Planning and Design Guide](#)
- Research paper on groundwater flooding in Staines – Paul, J.D. et al. (2025) '[Groundwater flooding of superficial gravels in an urbanized catchment](#),' [Journal of Flood Risk Management, 18\(2\)](#). This academic paper was not commissioned by Spelthorne Borough Council.

4.1 High Streets

Design Code Checklist

Development proposed within High Street Area Types must complete this checklist to self-assess compliance with the Spelthorne Design Code. Submit the completed checklist with your planning application.

REF	PG.	REQUIREMENT	DOES YOUR PROPOSAL COMPLY?				JUSTIFICATION
			Fully	Partially	No	N/A	If Partially or No , provide a reference to where in your planning application you have provided an evidenced justification If N/A please state why.
4.1.1	44	Building Heights	Fully	Partially	No	N/A	
4.1.2	44	Building Lines	Fully	Partially	No	N/A	
4.1.3	45	Building Grain	Fully	Partially	No	N/A	
4.1.4	45	Vertical Mix of Uses	Fully	Partially	No	N/A	
4.1.5	46	High Street Public Realm	Fully	Partially	No	N/A	
4.1.6	47	Shop Fronts	Fully	Partially	No	N/A	
4.1.7	47	Facades	Fully	Partially	No	N/A	

4.2 Town Centre Neighbourhoods

Design Code Checklist

Development proposed within Town Centre Neighbourhoods must complete this checklist to self-assess compliance with the Spelthorne Design Code. Submit the completed checklist with your planning application.

REF	PG.	REQUIREMENT	DOES YOUR PROPOSAL COMPLY?				JUSTIFICATION
			Fully	Partially	No	N/A	If Partially or No , provide a reference to where in your planning application you have provided an evidenced justification. If N/A please state why.
THE STREET AND GROUND FLOOR							
4.2.1.1	50	Active Frontages	Fully	Partially	No	N/A	
4.2.1.2	50	Spill-Out Space	Fully	Partially	No	N/A	
4.2.1.3	52	Street Networks and Design	Fully	Partially	No	N/A	
4.2.1.3a		Pedestrian Priority Streets	Fully	Partially	No	N/A	
4.2.1.3b		Multi-Modal Streets	Fully	Partially	No	N/A	
4.2.1.4	52	Street Trees and Planting	Fully	Partially	No	N/A	
SCALE AND MASSING							
4.2.2.1	54	Neighbourhood Massing Approach	Fully	Partially	No	N/A	
4.2.2.2	56	Development Typologies	Fully	Partially	No	N/A	
4.2.2.2a		Terraces, Back-to-Backs, Mews	Fully	Partially	No	N/A	

4.2.2.2b		Linear Blocks	Fully	Partially	No	N/A
4.2.2.2c		Villa Blocks	Fully	Partially	No	N/A
4.2.2.2d		Podiums and Towers	Fully	Partially	No	N/A
4.2.2.3	62	Tall Building Design	Fully	Partially	No	N/A
4.2.2.3a		Breaking Up Massing	Fully	Partially	No	N/A
4.2.2.3b		Scale of the Street	Fully	Partially	No	N/A
4.2.2.3c		Microclimate	Fully	Partially	No	N/A
OPEN SPACES						
4.2.3.1	64	Neighbourhood Open Space Approach	Fully	Partially	No	N/A
4.2.3.2	65	Safety and Security	Fully	Partially	No	N/A
4.2.3.3	66	Public Open Spaces	Fully	Partially	No	N/A
4.2.3.3a		Squares and Parks	Fully	Partially	No	N/A
4.2.3.3b		Courtyards, Pocket Parks	Fully	Partially	No	N/A
4.2.3.3c		Linear and Transit Spaces	Fully	Partially	No	N/A
4.2.3.4	68	Shared / Communal Open Spaces	Fully	Partially	No	N/A
4.2.3.4a		Ground-Level Gardens	Fully	Partially	No	N/A
4.2.3.4b		Podium Gardens	Fully	Partially	No	N/A

4.2.3.4c		Roof Gardens and Terraces	Fully	Partially	No	N/A
4.2.3.5	70	Landscape Character	Fully	Partially	No	N/A
4.2.3.5a		Hard Landscape	Fully	Partially	No	N/A
4.2.3.5b		Soft Landscape	Fully	Partially	No	N/A
4.2.3.5c		Street Furniture	Fully	Partially	No	N/A
4.2.3.5d		Street Trees	Fully	Partially	No	N/A
4.2.3.5e		Surface Water Drainage Features	Fully	Partially	No	N/A

HOMES AND PRACTICALITIES

4.2.4.1	72	Space Standards	Fully	Partially	No	N/A
4.2.4.2	73	Mix of Homes	Fully	Partially	No	N/A
4.2.4.3	73	Dwelling Aspect	Fully	Partially	No	N/A
4.2.4.4	74	Residential Entrances and Circulation	Fully	Partially	No	N/A
4.2.4.4a		Shared Entrances	Fully	Partially	No	N/A
4.2.4.4b		Private Entrances	Fully	Partially	No	N/A
4.2.4.5	75	Private Amenity Spaces	Fully	Partially	No	N/A
4.2.4.5a		Balconies	Fully	Partially	No	N/A
4.2.4.5b		Private Garden Space	Fully	Partially	No	N/A

4.2.4.6	76	Vehicle and Cycle Parking	Fully	Partially	No	N/A
4.2.4.6a		Visitor Cycle Parking	Fully	Partially	No	N/A
4.2.4.6b		Residents' Cycle Parknig	Fully	Partially	No	N/A
4.2.4.6c		Underground Parking	Fully	Partially	No	N/A
4.2.4.6d		Podium Parking	Fully	Partially	No	N/A
4.2.4.6e		Integrated Parking	Fully	Partially	No	N/A
4.2.4.6f		Surface or On-Street Parking	Fully	Partially	No	N/A

DETAIL AND RICHNESS

4.2.5.1	78	Townscape	Fully	Partially	No	N/A
4.2.5.2	79	Distinctive Buildings	Fully	Partially	No	N/A
4.2.5.2a		Marker Buildings	Fully	Partially	No	N/A
4.2.5.2b		Landmark Buildings	Fully	Partially	No	N/A
4.2.5.3	80	Design of Elevations	Fully	Partially	No	N/A
4.2.5.3a		Facade Structure	Fully	Partially	No	N/A
4.2.5.3b		Proportions	Fully	Partially	No	N/A
4.2.5.3c		Building Tops and Roofs	Fully	Partially	No	N/A
4.2.5.3d		Balconies	Fully	Partially	No	N/A

4.2.5.3e	Corners	Fully	Partially	No	N/A
----------	---------	-------	-----------	----	-----

4.2.5.3f	Windows and Fenestration	Fully	Partially	No	N/A
----------	--------------------------	-------	-----------	----	-----

CLIMATE CHANGE AND SUSTAINABILITY

4.2.6.1	84	Mitigation: Reducing Energy Use	Fully	Partially	No	N/A
---------	----	---------------------------------	-------	-----------	----	-----

4.2.6.2	85	Mitigation: Reducing Embodied Carbon	Yes	Partially	No	N/A
---------	----	--------------------------------------	-----	-----------	----	-----

4.2.6.3	85	Adaptation: Preparing for a Changing Climate	Yes	Partially	No	N/A
---------	----	--	-----	-----------	----	-----

4.3.1 Inner Suburban

Design Code Checklist: New Homes Or Apartments on Existing Streets

Development of new homes or apartments on existing streets proposed within Inner Suburban Area Types must complete this checklist to self-assess compliance with the Spelthorne Design Code. Submit the completed checklist with your planning application.

REF	PG.	REQUIREMENT	DOES YOUR PROPOSAL COMPLY?				JUSTIFICATION
			Fully	Partially	No	N/A	If Partially or No , provide a reference to where in your planning application you have provided an evidenced justification If N/A please state why.
DEVELOPMENT TYPE: NEW HOMES OR APARTMENTS ON EXISTING STREETS							
4.3.1.1	88	Layout Principles	Fully	Partially	No	N/A	
4.3.1.2	89	Built Form Parameters	Fully	Partially	No	N/A	
4.3.1.3	89	Roof Form	Fully	Partially	No	N/A	
4.3.1.4	89	Front Boundary Treatment	Fully	Partially	No	N/A	
4.3.1.5	90	Daylight, Privacy and Overlooking	Fully	Partially	No	N/A	
4.3.1.6	90	Access, Cycle and Vehicle Parking	Fully	Partially	No	N/A	
4.3.1.7	90	Apartment Development	Fully	Partially	No	N/A	
4.3.1.8	91	Detail, Richness and Materiality	Fully	Partially	No	N/A	

4.3.2 Inner Suburban

Design Code Checklist: Residential Extensions

Development of residential extensions proposed within Inner Suburban Area Types must complete this checklist to self-assess compliance with the Spelthorne Design Code. Submit the completed checklist with your planning application.

REF	PG.	REQUIREMENT	DOES YOUR PROPOSAL COMPLY?				JUSTIFICATION
			Fully	Partially	No	N/A	If Partially or No , provide a reference to where in your planning application you have provided an evidenced justification If N/A please state why.
DEVELOPMENT TYPE: RESIDENTIAL EXTENSIONS							
4.3.2.1	92	Context & Character	Fully	Partially	No	N/A	
4.3.2.2	92	Privacy & Outlook	Fully	Partially	No	N/A	
4.3.2.3	93	Daylight	Fully	Partially	No	N/A	
4.3.2.4	93	Side Extensions	Fully	Partially	No	N/A	
4.3.2.5	93	Dormers	Fully	Partially	No	N/A	

4.4.1 Suburban

Design Code Checklist: New Residential Neighbourhoods

Development of new residential neighbourhoods proposed within Suburban Area Types must complete this checklist to self-assess compliance with the Spelthorne Design Code. Submit the completed checklist with your planning application.

REF	PG.	REQUIREMENT	DOES YOUR PROPOSAL COMPLY?				JUSTIFICATION
			Fully	Partially	No	N/A	If Partially or No , provide a reference to where in your planning application you have provided an evidenced justification If N/A please state why.
DEVELOPMENT TYPE: NEW RESIDENTIAL NEIGHBOURHOODS							
4.4.1.1	96	Ensuring Distinctiveness	Fully	Partially	No	N/A	
4.4.1.2	96	Edges	Fully	Partially	No	N/A	
4.4.1.2a		Trees, Woodland and Hedgerows	Fully	Partially	No	N/A	
4.4.1.2b		Open Spaces	Fully	Partially	No	N/A	
4.4.1.2c		Watercourses and Water Bodies	Fully	Partially	No	N/A	
4.4.1.2d		Streets and Roads	Fully	Partially	No	N/A	
4.4.1.2e		Dual Carriageways	Fully	Partially	No	N/A	
4.4.1.2f		Railways	Fully	Partially	No	N/A	
4.4.1.2g		Residential	Fully	Partially	No	N/A	
4.4.1.2h		Local Facilities	Fully	Partially	No	N/A	
4.4.1.2i		Industry and Commercial Uses	Fully	Partially	No	N/A	

4.4.1.3	100	Movement: Streets	Fully	Partially	No	N/A
4.4.1.3a		Street Layout Approach	Fully	Partially	No	N/A
4.4.1.3b		Main Streets	Fully	Partially	No	N/A
4.4.1.3c		Secondary Streets	Fully	Partially	No	N/A
4.4.1.3d		Local or Residential Streets	Fully	Partially	No	N/A
4.4.1.3e		Mews and Lanes	Fully	Partially	No	N/A
4.4.1.4	102	Movement: Car Parking	Fully	Partially	No	N/A
4.4.1.4a		On-Plot Parking	Fully	Partially	No	N/A
4.4.1.4b		On-Street and Shared Parking	Fully	Partially	No	N/A
4.4.1.5	104	Open Spaces	Fully	Partially	No	N/A
4.4.1.5a		Open Spaces Amongst Homes	Fully	Partially	No	N/A
4.4.1.5b		Open Spaces on Edge of Built-up Area	Fully	Partially	No	N/A
4.4.1.6	106	Landscape Character	Fully	Partially	No	N/A
4.4.1.6a		Hard Landscape	Fully	Partially	No	N/A
4.4.1.6b		Soft Landscape	Fully	Partially	No	N/A
4.4.1.6c		Street Trees	Fully	Partially	No	N/A
4.4.1.6d		Surface Water Drainage Features	Fully	Partially	No	N/A

4.4.2 Suburban

Design Code Checklist: New Homes Or Apartments on Existing Streets

Development of new homes or apartments on existing streets proposed within Suburban Area Types must complete this checklist to self-assess compliance with the Spelthorne Design Code. Submit the completed checklist with your planning application.

REF	PG.	REQUIREMENT	DOES YOUR PROPOSAL COMPLY?				JUSTIFICATION
			Fully	Partially	No	N/A	If Partially or No , provide a reference to where in your planning application you have provided an evidenced justification If N/A please state why.
DEVELOPMENT TYPE: NEW HOMES OR APARTMENTS ON EXISTING STREETS							
4.4.2.1	108	Layout Principles	Fully	Partially	No	N/A	
4.4.2.2	109	Built Form Parameters	Fully	Partially	No	N/A	
4.4.2.3	109	Roof Form	Fully	Partially	No	N/A	
4.4.2.4	109	Front Boundary Treatment	Fully	Partially	No	N/A	
4.4.2.5	110	Daylight, Privacy and Overlooking	Fully	Partially	No	N/A	
4.4.2.6	110	Access, Cycle and Vehicle Parking	Fully	Partially	No	N/A	
4.4.2.7	110	Apartment Development	Fully	Partially	No	N/A	
4.4.2.8	111	Detail, Richness and Materiality	Fully	Partially	No	N/A	

4.4.3 Suburban

Design Code Checklist: Residential Extensions

Development of residential extensions proposed within Suburban Area Types must complete this checklist to self-assess compliance with the Spelthorne Design Code. Submit the completed checklist with your planning application.

REF	PG.	REQUIREMENT	DOES YOUR PROPOSAL COMPLY?				JUSTIFICATION
			Fully	Partially	No	N/A	If Partially or No , provide a reference to where in your planning application you have provided an evidenced justification If N/A please state why.
DEVELOPMENT TYPE: RESIDENTIAL EXTENSIONS							
S-X1	112	Context & Character	Fully	Partially	No	N/A	
S-X2	112	Privacy & Outlook	Fully	Partially	No	N/A	
S-X3	113	Daylight	Fully	Partially	No	N/A	
S-X4	113	Side Extensions	Fully	Partially	No	N/A	
S-X5	113	Dormers	Fully	Partially	No	N/A	

5.1 Staines-upon-Thames Town Centre

Design Code Checklist: Area of Change

Development within the Staines-upon-Thames Town Centre Area of Change must complete this checklist to self-assess compliance with the Spelthorne Design Code. Submit the completed checklist with your planning application.

What Area of Change Area Type is your application within? (tick multiple if across boundaries)

Have you completed a checklist for the general Area Type that the detailed Area Types sit within?

Does your proposal comply with the coding requirements set out?

5.1.1 Staines Village p122

----->

No checklist - design approach to be set out in Design & Access Statement

Fully

Partially

5.1.2 Historic Core p124

----->

High Street

No

N/A

5.1.3 Memorial Gardens p128

----->

Town Centre Neighbourhood

5.1.4 Station Path p132

----->

Town Centre Neighbourhood

5.1.5 London Road p136

----->

Town Centre Neighbourhood

5.1.6 Two Rivers p140

----->

Town Centre Neighbourhood

5.1.7 Elmsleigh p144

----->

Town Centre Neighbourhood

5.1.8 Railway Edges p148

----->

Town Centre Neighbourhood

If Partially or No, provide a reference to where in your planning application you have provided an evidenced justification

If N/A please state why.

5.2 Sunbury Cross

Design Code Checklist: Area of Change

Development within the Sunbury Cross Area of Change must complete this checklist to self-assess compliance with the Spelthorne Design Code. Submit the completed checklist with your planning application.

What Area of Change Area Type is your application within? (tick multiple if across boundaries)

Have you completed a checklist for the general Area Type that the detailed Area Types sit within?

Does your proposal comply with the coding requirements set out?

5.2.1 The Parade p156

----->

High Street

Fully

Partially

5.2.2 Staines Road West p157

----->

Suburban

No

N/A

5.2.3 Station Area p158

----->

Town Centre Neighbourhood

If Partially or No, provide a reference to where in your planning application you have provided an evidenced justification

5.2.4 Hanworth Road p159

----->

Town Centre Neighbourhood

If N/A please state why.

5.2.5 Central Area p160

----->

Town Centre Neighbourhood

Glossary

Access

This term has two broad meanings: The route(s) to a site and the route layout within a site, related to different modes of movement (foot, cycle, vehicular), and the inclusive approach to design, which aims to create a built environment which is accessible to everyone, regardless of age or ability.

Active frontage

A building frontage to the public realm which is characterised by entrances and windows (residential, commercial or retail), allowing interaction between the public realm and the use facing the street, as well as passive surveillance of the public realm.

More information on active frontages in town centre neighbourhoods is found under [4.2.1.1](#).

Area type

Parts of the local area that share common features and characteristics. For example, a suburban area type might bring together a number of different streets with common densities, heights, building line, under the umbrella term “Inner Suburban”. Common rules and parameters can then be applied to the “Inner Suburban” area type in the design code. Example area types are provided in the National Model Design Code, but area types should be defined locally.

The borough’s area types are defined at the start of Chapter 4. Staines-upon-Thames and Sunbury Cross Areas of Change have more detailed Area Types defined in Chapter 5.

Boundary treatment

The physical interface that delineates the public realm from a private building, crossing which enters a defensible zone before reaching the building entrance. Treatments can include planting, low fences or walls.

Borough-wide

Relating to the borough of Spelthorne.

Block

A building or set of continuous buildings within a plot.

Building line

The linear definition of a building’s frontage facing the street. Usually shared by different building typologies and sizes to organise the definition between the public street and private internal space of the building and urban block.

Building height

The height of a building. For the purposes of the Spelthorne Design Code, this is measured from pavement level to the top of the roof. For the purposes of determining the prevailing height in the area, the number of storeys can be also used. Minor projections above roof height (e.g. flues or chimneys) are not included.

Character

The combination of features of a building or a place that give it a distinctive identity compared with other buildings or areas.

Contemporary development

Contemporary development is the architecture of the 21st century. It is characterised by efficient layouts that use a combination of low rise, mid-rise and tall buildings in perimeter blocks to optimise capacity. These tend to be set within gridded street networks that are highly permeable and legible.

Conserve

Enhancing and protecting the existing character.

Context

The surrounding environment of a proposed development, including existing buildings, landscape and consented schemes.

Defensible space

The area occupying space between a building entrance and the boundary treatment. Typically associated with residential buildings, they provide a sense of spatial separation and visual privacy between the public street and private home at ground floor.

Density

In the case of residential development, a measurement of either the number of habitable rooms per hectare or the number of dwellings per hectare.

Design code

A set of illustrated design requirements that provide specific, detailed parameters for the physical development of a site or area. The graphic and written components of the code should build upon a design vision, such as a masterplan or other design and development framework for a site or area.

Design-led approach

Using urban design and architectural processes to prepare proposals that represent the optimum design response to a site, responding to the surrounding context of massing, connections, open spaces and other factors. This process should be evidenced through exploring a range of options.

Design process

The process of developing a proposal for a site. The design process is expected to follow good urban design principles set out in the National Design Guide and the National Model Design Code.

A full explanation of what is expected is contained in Chapter 2.

Dual aspect

A habitable unit with windows on two walls facing different directions.

Elevation

A vertical projection of one side of a building, showing a single façade.

Enclosure

The extent to which streets and open spaces are visually defined by buildings, walls and trees.

Façade

The external faces of a building, characterised by a choice of materials, windows, doors, entrances, and openings.

Fenestration

The arrangement of entrances, windows, balconies, and other openings on a building facade.

Formal / informal

A formal layout of streets and building groups is characterised by symmetrical or geometric plans and elevations. The features of an informal design include layout and elevations which are asymmetrical, winding and which relate to natural site characteristics.

Floor Area Ratio (FAR)

A metric used to calculate the density of developments regardless of building type and use. FAR is expressed as the ratio of a building's total floor area to the size of the plot upon which it is built.

Frontage

The front face of a building articulated with entrances and windows. Well defined frontage enables overlooking from the building out into the street or space, creating a positive relationship between the two.

Gateway

The marking of a point of entry to an area of character or to a specific development through a change built form, landscape materials or a key view to signify and reinforce the transition.

Grain

The general shape and direction of building footprints. Fine grain refers to the higher intensity of smaller plots or streets. Coarse grain refers to larger scale plots with fewer roads.

Green infrastructure

A network of multi-functional green space, urban and rural, which is capable of delivering a wide range of environmental and quality of life benefits for local communities.

Gridded Street Network

A style of street network defined by a repetition of streets and urban blocks intersecting at right angles, comprising an overall grid structure. Regular grid patterns allow for ease of accessibility and legibility.

Hierarchy

A logical sequence of spaces, streets or building forms, increasing or decreasing in size or density throughout a development.

Impermeable

An unconnected street or pedestrian network with a low frequency of routes, inhibiting easy passage of movement. Often associated with coarse urban grain patterns or illegible layouts such as cul-de-sacs or free form block estates.

Innovative development

A departure from both the traditional and modern approaches. Innovation could be technological or design-related.

Landmark building

Landmark buildings are prominent buildings that are easily recognisable and have significant cultural or historical value. Landmark buildings do not have to be tall, and they should be used sparingly in development.

More information on landmark buildings in town centre neighbourhoods is found under [4.2.5.2](#).

Layout

The layout of a block relates to the arrangement of buildings, open spaces and streets and the relationship between these components in creating an efficient, positive and legible environment.

Legible

The combination of buildings, streets, trees, and open spaces that use visual cues to create an intuitive and easily navigable environment.

Linear block

A building consisting of stacked apartments and maisonettes organised in a linear urban form. Can be stand alone and running parallel with a street to form a contemporary terrace, or form part of a block that forms the perimeter between the public street and private internal space.

More information on linear blocks in town centre neighbourhoods is found under [4.2.2.2](#).

Listed Building

A building that is included on the List of Buildings of Special Architectural or Historic Interest administered by Historic England on behalf of the Secretary of State for Digital, Culture, Media and Sport. Listed buildings are graded I, II* or II with grade I being the highest. Buildings within the curtilage of a listed building constructed before 1948 are also protected. The significance of a listed building may be external and/or internal.

Local Plan

The plan for the future development of the local area, drawn up by the local planning authority in consultation with the community. In the context of the Spelthorne Design Code, this refers to the Spelthorne Local Plan 2022-2037.

Low-rise buildings

Low-rise buildings are classified as buildings up to and including 3 storeys e.g. up to 9 metres.

Marker building

Marker buildings are memorable buildings that stand out from the surrounding built form. They can help people to navigate and make the townscape more distinctive and interesting.

More information on marker buildings in town centre neighbourhoods is found under [4.2.5.2](#).

Massing

The three-dimensional volume and structure of a building's urban form. Massing is expressed through the size, shape and scale of its different components. Commonly understood as the expression of a building without any finer architectural elements and details. Massing can influence the ways in which a building is perceived, particularly in regards to reducing the impact of visual bulk.

Mews

Traditionally a stables at the rear of a building along a back (service street). The term now typically describes quiet streets of smaller homes inserted within a larger block, with an intimate character and semi-private atmosphere.

More information on mews in town centre neighbourhoods is found under [4.2.2.2](#).

Mid-rise buildings

Mid-rise buildings are classified as buildings between 4 and 6 storeys e.g. between 12 and 18 metres.

Mixed-use / mixed-use development

Provision of a mix of complementary uses, such as residential, community and/or leisure uses, on a site or within a particular area.

National Model Design Code

The National Model Design Code provides detailed guidance on the production of design codes, guides and policies to promote successful design.

Overlooking

A term used to describe the effect when a development or building affords an outlook over adjoining land or property, often causing loss of privacy.

Over shadowing

The effect of a development or building on the amount of sunlight presently enjoyed by a neighbouring property, resulting in a shadow being cast over that neighbouring property.

Parade

A continuous row of shops or commercial units, typically in the town centre. They sometimes have residential accommodation above.

Passive surveillance

Design that increases the occupation and/or visibility of a space to deter crime.

Perimeter block

A perimeter block is an urban form that concentrates the development of a city block along its outermost - or public - edges to strongly define a boundary between public and private or semi-private space. This form is highly efficient by making best use of available land and avoiding surplus spaces that lack clear role or function. The blocks themselves are impermeable but are set within a highly permeable street network.

Permeable

A connected street or pedestrian network with a high frequency of routes that allow easy passage of movement, often associated with fine urban grain patterns.

Place

A space in the built environment that has some meaning for people due to the activities and uses which characterise the space, or the quality of the space itself.

Plot

An area of developable land less public open space, primary road infrastructure, and non-developable areas.

Plot coverage

The proportion of a site that is occupied by a building's footprint. The plot ratio of a development is calculated by dividing the building's footprint by the total area of a site.

Prevailing height

The average or typical building height within an area. Please see Building height above.

Primary Street

The principal route or main access. Dominant to the secondary street network joining it. Often wider and carrying more significant traffic volumes or a route for public transport.

Public realm

The public realm is any part of a site, area, village, town or city that everyone can use and enjoy, including streets, squares and parks. The public realm is very important for pedestrian movement, as it connects various places and buildings.

Rhythm

The repeated pattern of an element such as a building, street or architectural detail.

Roofline

The profile of the top edge of a building.

Roofscape

The appearance of buildings as seen along the skyline, as well as the uses and occupancies as seen from tall buildings.

Roof Form

The type of roof based on its three-dimensional size and shape, often belonging to and characteristic of different typologies. Roof forms can include flat, gabled, hipped, mansard, butterfly, saw-tooth and more.

Scale

Most commonly understood as building height, though scale is relative to another (usually neighbouring) building's height. It can also relate to the size of a building's different elements e.g. massing, fenestration, rather than purely its absolute building height.

Secured by Design

The national police scheme which aims to minimise crime and opportunities to commit crime through better design of buildings and places.

Secondary Street

Subordinate to the primary street. Often more local routes, within residential areas.

Setting

The physical (built and landscape), community and economic surroundings in which the development takes place.

Set back

A step-like recess in massing of upper storeys, used where proposed building heights exceed the shoulder height of street. This strategy can preserve the established street width ratio and allow daylight to reach lower storeys.

Shoulder

The part of a taller building where a set back occurs. It should be treated as a distinct part of an elevation, to crown the lower part of a building visible from the street. See also set back above.

More information on the use of shoulders can be found under [4.2.2.3](#).

Single aspect

A habitable unit with windows on one wall facing a single direction.

Storey / number of storeys

Number of storeys is described as the number of floors in the building that have all internal perimeter walls of full floor height. If there is additional accommodation in the roofspace that is created within a pitched or similar style roof, where all perimeter walls are not of full floor height, this would not count as a full storey.

A building containing X number of full storeys with additional accommodation in the roofspace would be called 'X storeys with rooms in the roofspace'. If there are multiple (Y) floors within the roofspace this would be described as 'X storeys with rooms in the roofspace contained in Y floors'.

Street hierarchy

A system of classifying different routes within a movement network. This is principally based on the type and volume of movements a route supports, as well as its characteristics in terms of neighbouring building scale, use and enclosure. The character of a route can change along its length e.g. High Street along an arterial route.

Suburban

An area on the edge of a large town or city, typically residential in character. Suburbs became common in the UK during the 19th and 20th centuries when the development of rail and road transport made commuting viable. Also defined as a distinct and coherent Area Type in Spelthorne.

Taller building

Building that exceeds prevailing height of the surrounding area (please see [4.2.2.3](#)).

Traditional development

Directly reflects the local vernacular and historic architectural styles, materials and features.

Townscape

The urban equivalent of landscape: the overall effect of the combination of buildings, changes of level, green spaces, boundary walls, colours and textures, street surfaces, street furniture, uses, scale, enclosure, views etc.

More information on townscape in town centre neighbourhoods is found under [4.2.5.1](#).

Typology

The classification of buildings into typical and easily recognisable types, based on shared characteristics such as scale, massing, layout, architectural style and period. This organisational device can also apply to urban blocks e.g. Perimeter Block, Free Form Block.

Urban Greening Factor (UGF)

A tool used to evaluate the quality and quantity of natural features proposed as part of a development, such as planting, waterbodies and green roofs, collectively referred to as urban greening.

More information on calculating the Urban Greening Factor can be found as part of Natural England's Green Infrastructure Framework.

Villa blocks

A building consisting of stacked apartments. A villa block is characterised by a central core and efficient circulation arrangement, typically with three to five dwellings per floor, per core. This enables habitable rooms to have views in multiple directions.

More information on villa blocks in town centre neighbourhoods is found under [4.2.2.2](#).

Wayfinding

The process of navigating through and around the development, using spatial and visual clues and/or markers.

Prepared for Spelthorne Borough Council by



Fathom Architects

